

Variety with design / Large choix design

Varietdad con diseño

CATÁLOGO
de PRODUCTO

Product catalog / Catalogue des produits

2022/23



BC3
COCINAS

Desde que se fundara en 1.982, BC3 ha experimentado un importante desarrollo industrial, tecnológico y comercial.

Lo componen varias fábricas distribuidas a nivel nacional que conforman un moderno complejo productivo de más de 65.000 metros cuadrados destinados a la fabricación de mobiliario para cocina, baño y hogar.

Así mismo, contamos con una amplia red comercial que abarca clientes nacionales e internacionales a los que se le ofrece la rapidez y calidad de servicio que precisan.

Since it was founded in 1.982, BC3 has made an important industrial, technological and commercial development.

Bc3 group is composed by different factories distributed all over Spain which make up a modern productive complex of 65.000 m² intended to produce kitchens, bathrooms and home units.

In addition, we dispose an extensive commercial department which work with national and international customers, offering high quality and fast reply to all of them.

Depuis 1982, BC3 a connu un important développement industriel, technologique et commercial.

Elle est composée de plusieurs usines réparties au niveau national qui constituent un complexe moderne de production de plus de 65.000 mètres carrés destiné à la fabrication de mobilier de cuisine, salle de bain et foyer.

Ainsi, nous disposons d'un important réseau commercial comprenant des clients nationaux et internationaux à qui nous offrons la rapidité et la qualité de service qui nous définissent.

0

CUERPOS

CABINETS
CAISSONS

— CUERPOS

— CABINETS

— CAISSONS

Pág.

0.2

1

LAMINADO

LAMINATE
MÉLAMINÉ/STRATIFIÉ

— SERIES / MODELOS

— SERIES / MODELS

— SÉRIES / MODÉLES

Pág.

1.2

— COMPLEMENTOS
- CORNISAS, ZÓCALOS...
- ELEMENTOS DECORATIVOS

— COMPLEMENTS
- CORNICE, PLINTH...
- DECORATIVE ELEMENTS

— COMPLEMENTS
- CORNICHE, SOCLE...
- DÉCORATIF

1.36

2

POSTFORMADO

POSTFORMING
POSTFORMAGE

— ENCIMERAS / MODELOS

— WORKTOPS / MODELS

— PLANS DE TRAVAIL / MODÉLES

Pág.

2.2

3

POLILAMINADO

POLILAMINATE
POLYMÈRE

— SERIES / MODELOS

— SERIES / MODELS

— SÉRIES / MODÉLES

Pág.

3.2

— COMPLEMENTOS
- CORNISAS, ZÓCALOS...
- ELEMENTOS DECORATIVOS

— COMPLEMENTS
- CORNICE, PLINTH...
- DECORATIVE ELEMENTS

— COMPLEMENTS
- CORNICHE, SOCLE...
- DÉCORATIF

3.20

4

LACADO

LACQUERED
LAQUE

— SERIES / MODELOS

— SERIES / MODELS

— SÉRIES / MODÉLES

Pág.

4.2

— COMPLEMENTOS
- CORNISAS, ZÓCALOS...
- ELEMENTOS DECORATIVOS

— COMPLEMENTS
- CORNICE, PLINTH...
- DECORATIVE ELEMENTS

— COMPLEMENTS
- CORNICHE, SOCLE...
- DÉCORATIF

4.24

5 MADERA WOOD BOIS

			Pág.
— SERIES / MODELOS	— SERIES / MODELS	— SÉRIES / MODÈLES	5.2
— COMPLEMENTOS - CORNISAS, ZÓCALOS... - ELEMENTOS DECORATIVOS	— COMPLEMENTS - CORNICE, PLINTH... - DECORATIVE ELEMENTS	— COMPLEMENTS - CORNICHE, SOCLE... - DÉCORATIF	5.16

6 PORCELÁNICO PORCELAIN PORCELAINE

			Pág.
— SERIES / MODELOS	— SERIES / MODELS	— SÉRIES / MODÈLES	6.2

7 ALUMINIO / ACERO ALUMINUM / STEEL ALUMINIUM / ACIER

			Pág.
— ESTRUCTURAS DE ALUMINIO	— STRUCTURES OF ALUMINUM	— STRUCTURES EN ALUMINIUM	7.2
— ESTRUCTURAS MODULARES	— MODULAR STRUCTURES	— STRUCTURES MODULAIRES	7.2
— VITRINAS ALUMINIO	— ALUMINUM GLASS DOORS	— VITRÉE ALUMINIUM	7.3
— ZÓCALOS	— PLINTHS	— SOCLES	7.6

8 ACCESORIOS / HERRAJES COMPLEMENTS / HARDWARE ACCESSORIES / FERRAGE

			Pág.
— TIRADORES	— HANDLES	— TIREURS	8.3
— CAJONES	— DRAWERS	— TIROIRS	8.13
— ESCURREPLATOS	— PLATE RACK	— PORTE-PLAQUE	8.30
— BISAGRAS / SIST. DE APERTURA	— HINGES / OPENING SYSTEM	— CHARNIÈRES / SYS.D'OVERTURE	8.31
— HERRAJES VARIOS - PATAS Y COLGADORES - ACCESORIOS DE ENCIMERA - REJILLAS Y MARCOS - HERRAJES DE PERSIANA - SOPORTES ESTANTES - PROTECTORES	— SEVERAL HARDWARE - LEG & HANGERS - WORKTOPS COMPLEMENTS - GRIDS & FRAMEWORKS - BLIND SHUTTERS - SHELF SUPPORTS - PROTECTORS	— MATÉRIEL DIVERS - PIED ET DANGLER - ACCESOIRES PLAN DE TRAVAIL - GRILLES ET CADRES - VOLETS MATÉRIELS - SUPPORTS D'ETAGÈRE - PROTECTEURS	8.40
— INTERIORISMO - SERIE COMPACT - SERIE LUX - SERIE BASIC - CONTENEDORES DE RESIDUOS	— BUILT-IN ACCESORIES - COMPACT SERIES - LUX SERIES - BASIC SERIES - WASTE CONTAINERS	— INTÉRIORISME - SÉRIE COMPACT - SÉRIE LUX - SÉRIE BASIC - CONTENEURS DE DÉCHETS	8.51
— SISTEMAS DE ILUMINACIÓN	— LIGHTING SYSTEM	— SYSTÈME D'ÉCLAIRAGE	8.73
— CRISTALES	— GLASSES	— VERRES	8.78

En este catálogo técnico se pueden localizar las especificaciones técnicas del producto BC3, de manera útil y cómoda.

Dentro de este nuevo manual técnico le ofrecemos la información referida a:

- Producto terminado.
- Despiece de producto.
- Interiorismo.

En las páginas siguientes encontrará capítulos indicados con separaciones visibles, de las distintas familias de producto, y en cada una la información técnica sobre modelos, acabados y módulos que BC3 Cocinas ofrece.

Hemos intentado hacer de este manual una herramienta útil de manejar, por lo que en pocas páginas tiene toda la información exacta para el proyecto de su cocina, con todas las características colores, modelos y el máximo de variantes posibles por elemento.

En nuestro esfuerzo y deseo por mostrar, con la mejor calidad nuestros productos, en este catálogo contamos con los mejores medios y controles para que la impresión de los mismos resulte lo más real posible y semejante a la realidad, siempre teniendo en cuenta los soportes y pigmentos empleados en el proceso de imprenta siendo totalmente distintos a los utilizados en nuestras fábricas.

This technical catalogue has been designed to localization of the technical specifications of BC-3 as convenient and useful as possible.

Within this new handbook we offer technical information relating to:

- Finished product.
- Cutting of product.
- Interior Design.

On the following pages you will find chapters listed with visible separations of the different product families, and technical information on models, finishes and modules offering by BC3 kitchens.

We have tried to make this manual a useful tool handle, so in few pages have all the accurate information for the project of your kitchen, with all the features colors, models and the maximum of possible variants by element.

In our effort and desire to show, with the best quality of our products, in this catalogue have the best media and controls so that the printing of them look as real as possible and similar to reality, always keeping in mind the brackets and pigments used in the printing process are completely different to those used in our factories.

Le catalogue technique. La tarife de prix es dessiné pour l'évaluation, la localisation de spécification techniques du produit BC3 sera aussi confortable et utile que possible.

A l'intérieur de ce nouveau manuel technique nous vous offrons l'information rapportée à:

- Produit terminé.
- Dépeçage du produit.
- Intérieurisme.

Dans les pages suivante vous trouverez 4 grands groupes parfaitement indiqués, avec des séparation visible de familles distinctes de produit et dans charune d'elles. Les groupes distincte de prix et l'information technique des modèles, terminaisons et de modules que BC3 cuisines offre.

Nous avons essayée de faire de ce manuel un outil utile de manier, avec la localisation facile des groupes de prix, en certaines pages vous avez toute l'information pour l'évaluation exacte de votre projet de cuisine avec toutes les caractéristiques et le maximum de variantes possibles par element.

Dans notre effort el le desir pour montrer avec la meillure qualité nos produits dans ce catalogue, nous comptons avec les meilleurs moyens et les contrôles pour que l'édition des memes soit la plus réelle et semblable possible par rapport à la réalité, toujours en ayant compte que les supports et les pigments employés dans le traitement d'imprimerie sont tout á fait differents à ceux que nous avons utilisé por nous produits finis.

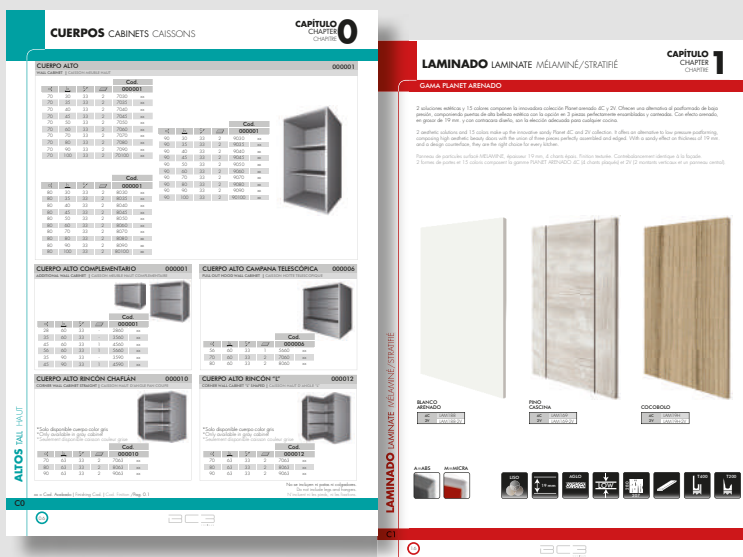

Cómo componer el código de un artículo:
Cod. Artículo + Cod. Medida + Cod. Acabado
Ej. Casco Alto 70x60 blanco = 000001-7060-B



RELACIÓN DE NORMAS DE CALIDAD QUE CUMPLEN LOS COMPONENTES DE NUESTRAS COCINAS.
RELATION OF QUALIT PROCEDURE THAT FULFILL THE COMPONENTS OF OUR KITCHEN.
RELATION DES NORMES DE QUALITÉ QUE RESPECTENT LES COMPOSANTS DE NOS CUISINES.

	<p>Ensayo de resistencia a cargas estáticas para entrepaños. Endurance test to static loads for piers. Essai de résistance aux charges statiques pour étagères.</p>	<p>Ensayo de resistencia a productos alimenticios fríos. Ensayo de revestimientos superficiales de los planos de trabajo. Endurance test to cold food products. Test of superficiais coating of worktops. Essai de résistance aux produits alimentaires froids. Essais de revêtement superficiels des plans de travail.</p>	
	<p>Ensayo de resistencia a cargas mecánicas sobre cajones. Endurance test to mechanical loads for drawers. Essai de résistance à des charges mécaniques sur les tiroirs.</p>	<p>Ensayo de resistencia a productos alimenticios calientes. Ensayo de revestimientos superficiales de los planos de trabajo. Endurance test to hot food products. Test of superficiais coatings of worktops. Essai de résistance aux produits alimentaires chauds. Essais de revêtement superficiels des plans de travail.</p>	
	<p>Ensayo de resistencia a cargas mecánicas sobre paredes verticales de muebles bajos (frente del mueble). Endurance test to mechanical loads for the doors of the base cabinet. Essai de résistance à des chargues mécaniques sur les façades des meubles bas.</p>	<p>Ensayo de resistencia a productos de limpieza. Ensayo de revestimientos superficiales de los planos de trabajo. Endurance test to products of cleanliness. Test of superficiais coatings of worktops. Essai de résistance aux produits de nettoyage. Essais de revêtement superficiels des plans de travail.</p>	
	<p>Ensayo de resistencia de cajones a cargas concentradas en su extremo y de las guías de cajones. Endurance test to static loads for drawers and theirs slides. Essai de résistance des tiroirs et de leurs coulisses aux charges concentrées sur leur extrêmes.</p>	<p>Ensayo de resistencia al calor seco a 180°C. Ensayo de revestimientos superficiales de los planos de trabajo. Endurance test to the dry heat to 180°C. Test of superficiais coatings of worktops. Essai de résistance à la chaleur sèche à 180° C. Essais de revêtement superficiels des plans de travail.</p>	
	<p>Ensayo de maniobrabilidad brusca de puerta. Endurance test to sudden use of the doors. Essai de manoeuvre brusque des portes.</p>	<p>Ensayo de resistencia al vapor de agua. Ensayo de revestimientos superficiales de los planos de trabajo. Endurance test to the water steam. Test of superficiais coatings of worktops. Essai de résistance à la vapeur d'eau. Essais de revêtement superficiels des plans de travail.</p>	
	<p>Ensayo de apertura y cierre no brusco de puertas. Endurance test to the soft opening and closing of doors. Essai d'ouverture et fermeture non brusque de portes.</p>	<p>Ensayo de resistencia a la abrasión. Ensayo de revestimientos superficiales de los planos de trabajo. Endurance test to the abrasion. Test of superficiais coatings of worktops. Essai de résistance à l'abrasion. Essais de revêtement superficiels des plans de travail.</p>	
	<p>Ensayo de apertura y cierre no brusco de cajones. Endurance test to the soft opening and closing of the drawers. Essai d'ouverture et fermeture non brusque des tiroirs.</p>	<p>Ensayo de resistencia al impacto por caída de bola. Ensayo de revestimientos superficiales de los planos de trabajo. Endurance test to the impact of a ball fall. Test of superficiais coatings of worktops. Essai de résistance à l'impact de chutes de balle. Essais de revêtement superficiels des plans de travail.</p>	
	<p>Ensayo de resitencia a los productos alimenticios. Planos que no sean de trabajo. Endurance test to the food productct. Surfaces different to the worktop. Essai de résistance aux produits alimentaires. Surfaces qui ne sont pas des plans de travail.</p>	<p>Ensayo de adhesión del recubrimiento al soporte. Ensayo de revestimientos superficiales de los planos de trabajo. Test of adhesion of the covering to the support. Test of superficiais coatings of worktops. Essai d'adhésion du recouvrement du support. Essais de revêtement superficiels des plans de travail.</p>	
	<p>Ensayo de reistencia a productos de limpieza. Planos que no sean de trabajo. Endurance test to the products of cleanliness. Superficie different to the worktop. Essai de résistance aux produits de nettoyage. Surfaces qui ne sont pas des plans de travail.</p>	<p>Ensayo de resistencia a la corrosión de herrajes y elementos metálicos. Endurance test to the corrosion of iron-works and metallic elements. Essai de résistance à la corrosion de ferrures et d'éléments métalliques.</p>	
	<p>Ensayo de adhesión del recubrimiento. Recubrimientos a base de chapas de madera o materiales plásticos. Planos que no sean de trabajo. Test of adhesion of covering. Coverings based on sheet of wood or plastic materials. Superficie different to the worktop. Essai d'adhésion du recouvrement. Recouvrement à base de couche de bois ou matériel plastique. Surfaces qui ne sont des plans de travail.</p>	<p>Ensayo de resistencia al agua. Endurance test to the water. Essai de résistance à l'eau.</p>	

PICTOGRAMAS

PICTOGRAM

PICTOGRAMME

	Consultar Consult Consulter		Cacerolero Pan drawer Coffre
	Ver capítulo See chapter Voir le chapitre		Frente cajón Drawer front Façade de tiroir
	Medidas Measures Mesures		Frente cacerolero Pan drawer front Façade de coffre
	Altura Height Hauteur		Baja presión Low pressure Basse pression
	Anchura Width Largeur		Media presión Medium pressure Moyenne pression
	Profundidad Depth Profondeur		Alta presión High pressure Haute pression
	Grosor Thickness Épaisseur		Aglomerado Agglomerate Aggloméré
	Diámetro Diameter Diamètre		M.D.F. M.D.F. M.D.F.
	Ancho puerta Door width Largeur porte		Tablero marino Marine board Contreplaqué Marine
	Ancho cajón Drawer width Tiroir porte		Tablero liso Flat board Planche lisse
	Ángulo de apertura Opening angle Angle d'ouverture		Plafón rechapado Marine board Plafon plaqué
	Peso soportado Weight supported Poids supporté		Plafón macizo Marine board Plafon massif
	Capacidad en litros Capacity in liters Capacité en litres		Tablero Board Planche
	Acabado Finishing Finir		Bandas Band Bandes
	Estante Shelves Étagères		Corniluz / Regleta Cornice-Pelmet / Fillers Corniche d'éclairage / Fileur
	Cuerpo Cabinet Caisson		Corniluz Cornice-Pelmet Corniche d'éclairage
	Puerta Door Porte		Cornisa Clásica Classic cornice Corniche classique
	Cristal Glass Verre		Cornisa Época Antique cornice Corniche époque
	Colgador oculto Hidden hanger Jous de suspension		Portaluz Clásico Classic pelmet Support d'éclairage classic
	Bisagra Hinge Charnière		Portaluz Época Antique pelmet Support d'éclairage d'époque
	Pata Leg Pied		Tirador 400 Handle 400 Poignée 400
	Cajón Drawer Tiroir		

BCB
COCINAS

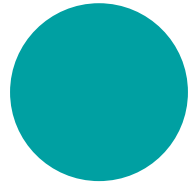

Cuerpos
Cabinets
Caissons



MUEBLE 16 UNIT 16 MEUBLE 16



Mecanizado colgador oculto
Hidde hangers
Ferrures de fixation d'éléments hauts



Soporte estante
Shelf bracket
Support d'étagère

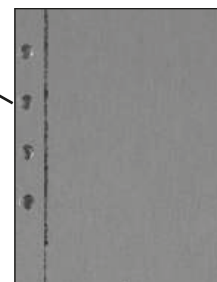

Canelado
Rear slot
Rainurage

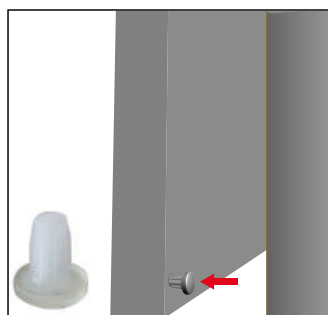

Tope amortiguador
Bumper stop
Perçage des embases des pieds

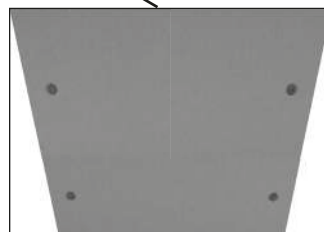

Mecanizado pata
Leg machined
Préperçage des embases de pieds

Realizados en tablero melamínico de 16 mm. de grosor, laminado a dos caras mediante revestimiento de 100 gr/m², con todos los cantos terminados con canto polimérico, excepto la trasera en tablero melamínico de 8 mm. revestido a dos caras.
El retranqueo es de 16 mm. en los muebles altos y 50 mm en los bajos y columnas. Incorporan baldas de iguales características con fijación mediante soporte antivuelco.

Made in 16 mm thick, double side 100gr/m² melamine faced chipboard, and all edges Polymer edgebanded, except 8 mm doublé side 100 gr/m² melamine faced chipboard back panel.
The setback gap is 16 mm in all units and 50 mm in base and tall units.
Same characteristics shelves included, fixed to the unit with an anti-overturn stand.

Caissons fabriqués en panneaux de particules surfacés mélaminés aux deux faces, de 16 mm d'épaisseur, 100 gr/m², avec tous les chants plaqués en ABS, sauf le fond qui est en ppsm de 8 mm d'épaisseur aux deux faces.
Le vide sanitaire est de 16 mm pour les meubles hauts et de 50 mm pour les meubles bas et armoires.
Les étagères sont identiques au caisson, tenues par des fixations anti-basculantes.

Colores de cuerpos | Colours of cabinets | Couleurs caissons



xx = Cod. Acabado | Finishing Cod. | Cod. Finition

		Cod.
Blanco White Blanc		- B
Gris Grey Gris		- G



Mecanizado colgador oculto
Hidde hangers
Ferrures de fixation d'éléments
hauts

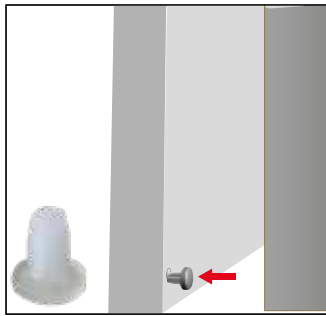

Tope amortiguador
Bumper stop
Perçage des embases des pieds

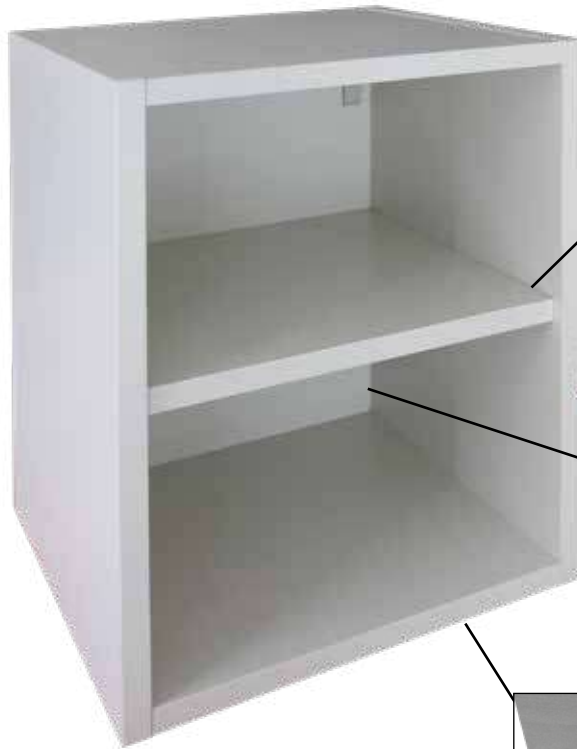

Soporte estante
Shelf bracket
Support d'étagère

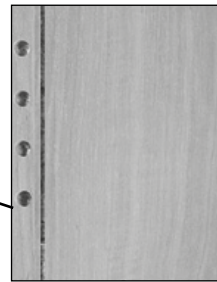

Canelado
Rear slot
Rainurage

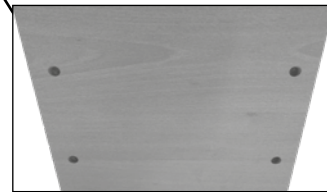

Mecanizado pata
Leg machined
Perçage des embases des pieds

Realizados en tablero melamínico de 19 mm. de grosor, laminado a dos caras mediante revestimiento de 100 gr/m², con todos los cantos terminados con canto polimérico y sellados con cola poliuretánica (Cola Pur), excepto la trasera en tablero melamínico de 8 mm. revestido a dos caras. El retranqueo es de 16 mm. en los muebles altos y 50 mm en los bajos y columnas. Incorporan baldas de iguales características con fijación mediante soporte antivuelco.

Made in 19 mm thick, double side 100gr/m² melamine faced chipboard, and all edges Polymer edgebanded, and sealed with polyurethane glue (Pur Glue) except 8 mm doublé side 100 gr/m² melamine faced chipboard back panel. The setback gap is 16 mm in all units and 50 mm in base and tall units. Same characteristics shelves included, fixed to the unit with an anti-overturn stand.

Caissons fabriqués en panneaux de particules surfacés mélaminés aux deux faces, de 19 mm d'épaisseur, 100 gr/m², avec tous les chants plaqués en ABS et scellé avec de la colle polyuréthane (Colle Pur), sauf le fond qui est en ppsm de 8 mm d'épaisseur aux deux faces. Le vide sanitaire est de 16 mm pour les meubles hauts et de 50 mm pour les meubles bas et armoires. Les étagères sont identiques au caisson, tenues par des fixations anti-basculantes.

Colores de cuerpos | Colours of cabinets | Couleurs caissons



NEW*

xx = Cod. Acabado | Finishing Cod. | Cod. Finition

		Cod.
Blanco hidrófugo White waterproof Blanc imperméable		BHE
Antracita Anthracite Anthracite		- A
Roble Aurora Oak Aurora Chêne Aurora		AE
Ditex Ditex Ditex		T

* Novedad a partir de 2023. Consultar | New product available from 2023. Consult | Nouveau à partir de 2023. Consulter

CARACTERÍSTICAS ESTÁNDAR					
	MUEBLE 16	MUEBLE 19			
COLGADOR	 Rapid	 Rapid			
PATA	 PLUS Reforzada				
BISAGRA	  Salice Blum Blumotion	  Blum Blumotion			
PROTECTOR FREGADERO	Mueble 16  Protector fregadero ABS	Mueble 19  Protector fregadero Termoplástico			
CAJONES	  Grass Nova XP Grass Nova Pro Scala Grass Vionaro Ekaline				
SISTEMA DE ALZAMIENTO	 Plegable HF	 Oblicuo HS	 Vertical HL	 Abatible HK	 Abatible HK-S
INTERIORISMO				Serie Lamina Antracita Serie Compac Cromo Blanco Serie Compac Antracita Serie Lux	

CUERPO ALTO 80

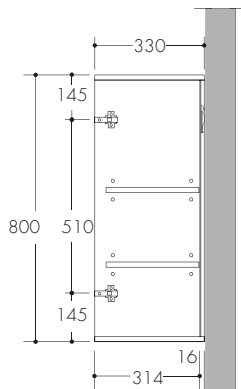

CUERPO ALTO

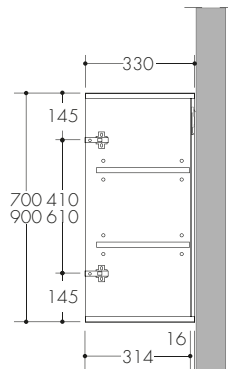

CUERPO SOBREENCIMERA

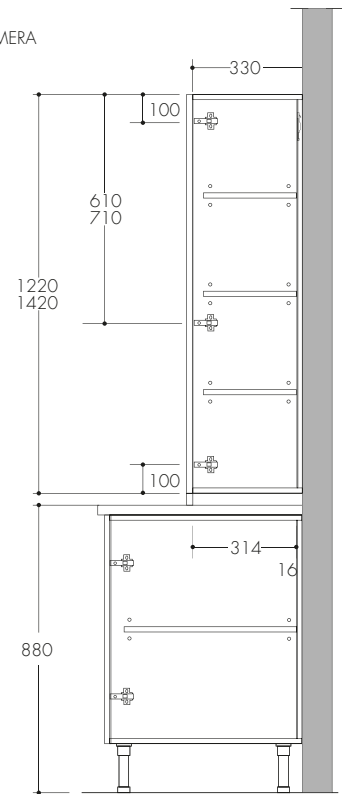

CUERPO BAJO 80

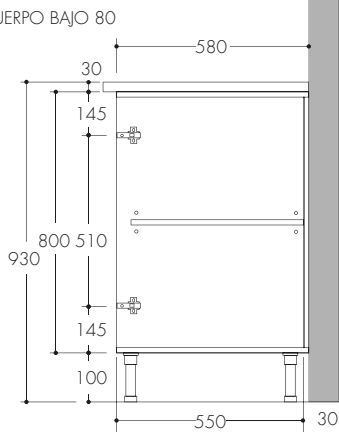

CUERPO BAJO

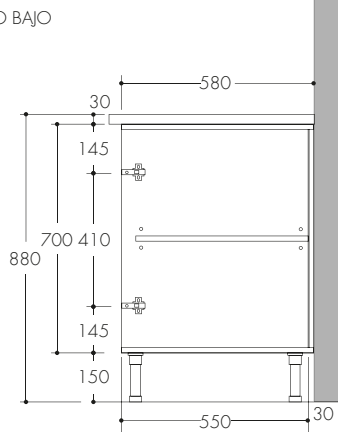

CUERPO SEMICOLUMNA

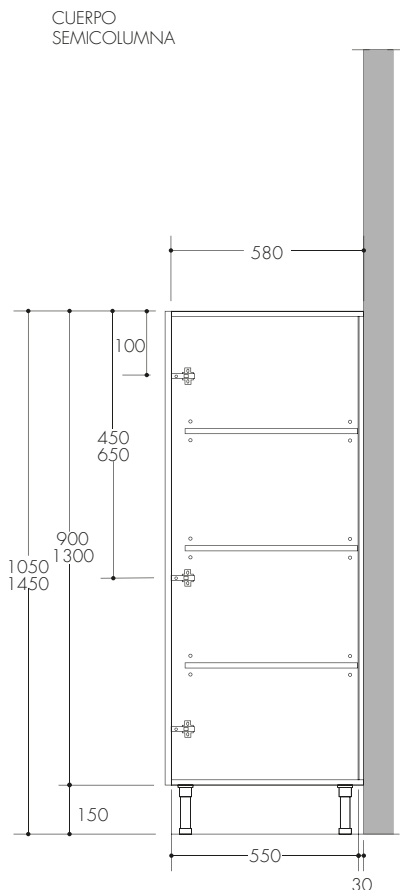

CUERPO COLUMNA

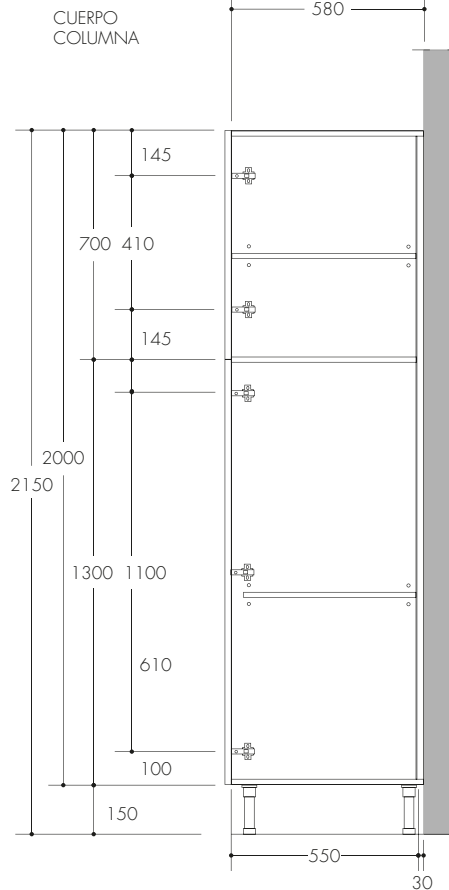

CUERPO COLUMNA

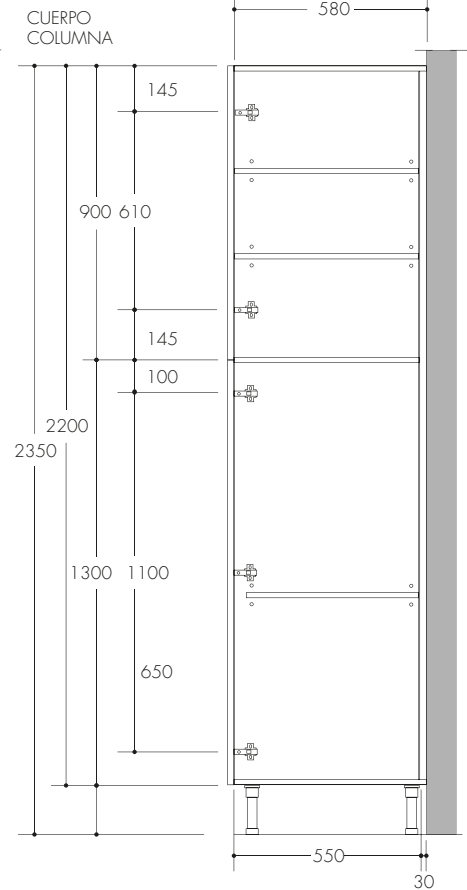

Nota: consultar medidas según color de acabado | Note: check measurements according to finish color | Remarque: vérifier les mesures selon la couleur de finition

CUERPO ALTO

000001

WALL CABINET | CAISSON MEUBLE HAUT

				Cod.	
a†	b	c	□	000001	
70	30	33	2	7030	xx
70	35	33	2	7035	xx
70	40	33	2	7040	xx
70	45	33	2	7045	xx
70	50	33	2	7050	xx
70	60	33	2	7060	xx
70	70	33	2	7070	xx
70	80	33	2	7080	xx
70	90	33	2	7090	xx
70	100	33	2	70100	xx

				Cod.	
a†	b	c	□	000001	
80	30	33	2	8030	xx
80	35	33	2	8035	xx
80	40	33	2	8040	xx
80	45	33	2	8045	xx
80	50	33	2	8050	xx
80	60	33	2	8060	xx
80	70	33	2	8070	xx
80	80	33	2	8080	xx
80	90	33	2	8090	xx
80	100	33	2	80100	xx

				Cod.	
a†	b	c	□	000001	
90	30	33	2	9030	xx
90	35	33	2	9035	xx
90	40	33	2	9040	xx
90	45	33	2	9045	xx
90	50	33	2	9050	xx
90	60	33	2	9060	xx
90	70	33	2	9070	xx
90	80	33	2	9080	xx
90	90	33	2	9090	xx
90	100	33	2	90100	xx



CUERPO ALTO COMPLEMENTARIO

000001

ADDITIONAL WALL CABINET | CAISSON MEUBLE HAUT COMPLEMENTAIRE



				Cod.	
a†	b	c	□	000001	
28	60	33	-	2860	xx
35	60	33	-	3560	xx
45	60	33	1	4560	xx
60	60	33	1	6060	xx
35	90	33	-	3590	xx
45	90	33	1	4590	xx

CUERPO ALTO CAMPANA TELESCÓPICA

000006

PULL OUT HOOD WALL CABINET | CAISSON HOTTE TELESCOPIQUE



				Cod.	
a†	b	c	□	000006	
60	60	33	1	6060	xx
70	60	33	2	7060	xx
80	60	33	2	8060	xx

CUERPO ALTO RINCÓN "L"

000012

CORNER WALL CABINET "L" SHAPED | CAISSON HAUT D'ANGLE "L"



				Cod.	
a†	b	c	□	000012	
70	63	33	2	7063	xx
80	63	33	2	8063	xx
90	63	33	2	9063	xx

No se incluyen ni patas ni colgadores.
Do not include legs and hangers.
N'incluent ni les pieds, ni les fixations.

xx = Cod. Acabado | Finishing Cod. | Cod. Finition /Pag. 0.2

Nota: consultar medidas según color de acabado | Note: check measurements according to finish color | Remarque: vérifier les mesures selon la couleur de finition

CUERPO BAJO

000040

BASE CABINET | CAISSON MEUBLE BAS

					Cod.	
a†	b	c	▭		000040	
70	30	58	1	7030	xx	
70	35	58	1	7035	xx	
70	40	58	1	7040	xx	
70	45	58	1	7045	xx	
70	50	58	1	7050	xx	
70	60	58	1	7060	xx	
70	70	58	1	7070	xx	
70	80	58	1	7080	xx	
70	90	58	1	7090	xx	
70	100	58	1	70100	xx	
70	120	58	1	70120	xx	

					Cod.	
a†	b	c	▭		000040	
80	30	58	1	8030	xx	
80	35	58	1	8035	xx	
80	40	58	1	8040	xx	
80	45	58	1	8045	xx	
80	50	58	1	8050	xx	
80	60	58	1	8060	xx	
80	70	58	1	8070	xx	
80	80	58	1	8080	xx	
80	90	58	1	8090	xx	
80	100	58	1	80100	xx	
80	120	58	1	80120	xx	

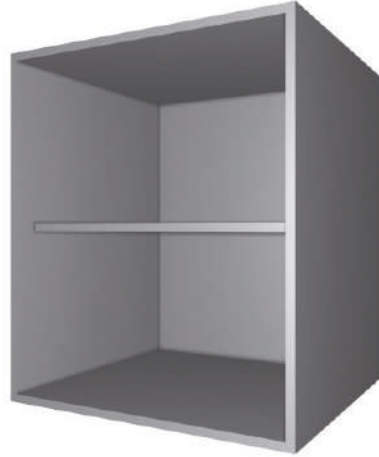

CUERPO BAJO FREGADERO / HORNO 60

000041/43

SINK BASE CABINET / OVEN 60 | CAISSON MEUBLE SOUS-ÉVIER / FOUR 60

					Cod.	
a†	b	c	▭		000041/43	
70	45	58	-	7045	xx	
70	50	58	-	7050	xx	
70	60	58	-	7060	xx	
70	70	58	-	7070	xx	
70	80	58	-	7080	xx	
70	90	58	-	7090	xx	
70	100	58	-	70100	xx	
70	120	58	-	70120	xx	
70	135	58	-	70135	xx	

					Cod.	
a†	b	c	▭		000041/43	
80	45	58	-	8045	xx	
80	50	58	-	8050	xx	
80	60	58	-	8060	xx	
80	70	58	-	8070	xx	
80	80	58	-	8080	xx	
80	90	58	-	8090	xx	
80	100	58	-	80100	xx	
80	120	58	-	80120	xx	
80	135	58	-	80135	xx	



CUERPO BAJO RINCÓN "L"

000052

CORNER BASE CABINET | CAISSON MEUBLE BAS D'ANGLE

					Cod.	
a†	b	c	▭		000052	
70	93	58	1	7093	xx	
70	108	58	1	70108	xx	
80	93	58	1	8093	xx	
80	108	58	1	80108	xx	

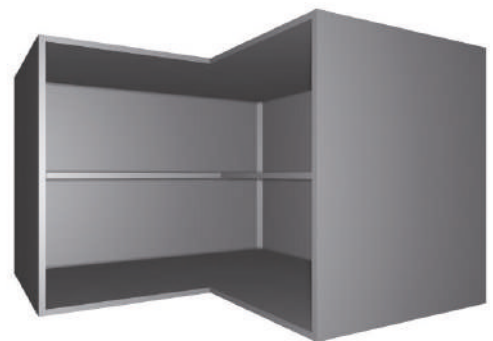

xx = Cod. Acabado | Finishing Cod. | Cod. Finition /Pag. 0.2

Nota: consultar medidas según color de acabado. | Note: check measurements according to finish color
Remarque: vérifier les mesures selon la couleur de finition

No se incluyen ni patas ni colgadores.
Do not include legs and hangers.
N'incluent ni les pieds, ni les fixations.

CUERPO SEMICOLUMNA

000081

SEMI-TALL CABINET | DEMI-COLONNE



				Cod.	
a↓	b→	↙	▭	000081	
90	60	58	2	9060	xx
130	60	58	3	13060	xx

CUERPO COLUMNA

000060

TALL CABINET | CAISSON COLONNE



				Cod.	
a↓	b→	↙	▭	000060	
200	40	58	2	20040	xx
200	45	58	2	20045	xx
200	60	58	2	20060	xx
220	40	58	2	22040	xx
220	45	58	2	22045	xx
220	60	58	2	22060	xx
230	40	58	2	23040	xx
230	45	58	2	23045	xx
230	60	58	2	23060	xx

CUERPO COLUMNA HORNO + MICRO

000063

MICROWAVE + OVEN TALL CABINETS | CAISSON COLONNE FOUR + MICRO-ONDES



				Cod.	
a↓	b→	↙	▭	000063	
200	60	58	2	20060	xx
220	60	58	2	22060	xx
230	60	58	2	23060	xx

xx = Cod. Acabado | Finishing Cod. | Cod. Finition /Pag. 0.2

Nota: consultar medidas según color de acabado | Note: check measurements according to finish color

Remarque: vérifier les mesures selon la couleur de finition

No se incluyen ni patas ni colgadores.

Do not include legs and hangers.

N'incluent ni les pieds, ni les jeux de suspension.

BANDA CANELADA 012001

SLOTTED BOARD | PANNEAU AVEC RAINURE

		Cod.	
a _t	c	012001	
285	33	28533	xx
285	58	28558	xx



BANDA NO CANELADA 011001

NO SLOTTED BOARD | PANNEAU SANS RAINURE

		Cod.	
a _t	c	011001	
285	62	28562	xx



ESTANTE 004001/004040

SHELVES | ETAGERE



Estante alto
Top shelf
Etagere haute



Estante bajo
Low shelf
Etagere basse

		Cod.				Cod.	
b	c	004001		b	c	004040	
26,6	29,3	30	xx	26,6	50,8	30	xx
31,6	29,3	35	xx	31,6	50,8	35	xx
36,6	29,3	40	xx	36,6	50,8	40	xx
41,6	29,3	45	xx	41,6	50,8	45	xx
46,6	29,3	50	xx	46,6	50,8	50	xx
56,6	29,3	60	xx	56,6	50,8	60	xx
66,6	29,3	70	xx	66,6	50,8	70	xx
76,6	29,3	80	xx	76,6	50,8	80	xx
86,6	29,3	90	xx	86,6	50,8	90	xx
96,6	29,3	100	xx	96,6	50,8	100	xx
		116,6	50,8	120	xx		

TRASERA 6MM 014001

6MM BACK PANEL | FOND DU MEUBLE 6 MM

		Cod.	
a _t	c	014001	
275	210	275210	xx



xx = Cod. Acabado | Finishing Cod. | Cod. Finition /Pag. 0.2

Nota: consultar medidas según color de acabado | Note: check measurements according to finish color | Remarque: vérifier les mesures selon la couleur de finition

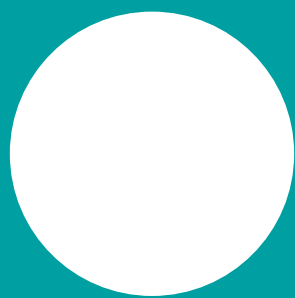

Cuerpos
Cabinets
Caissons

la base de la cocina

BC3
COCINAS

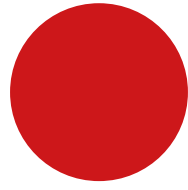

Laminado
Laminate
Mélaminé/Stratifié

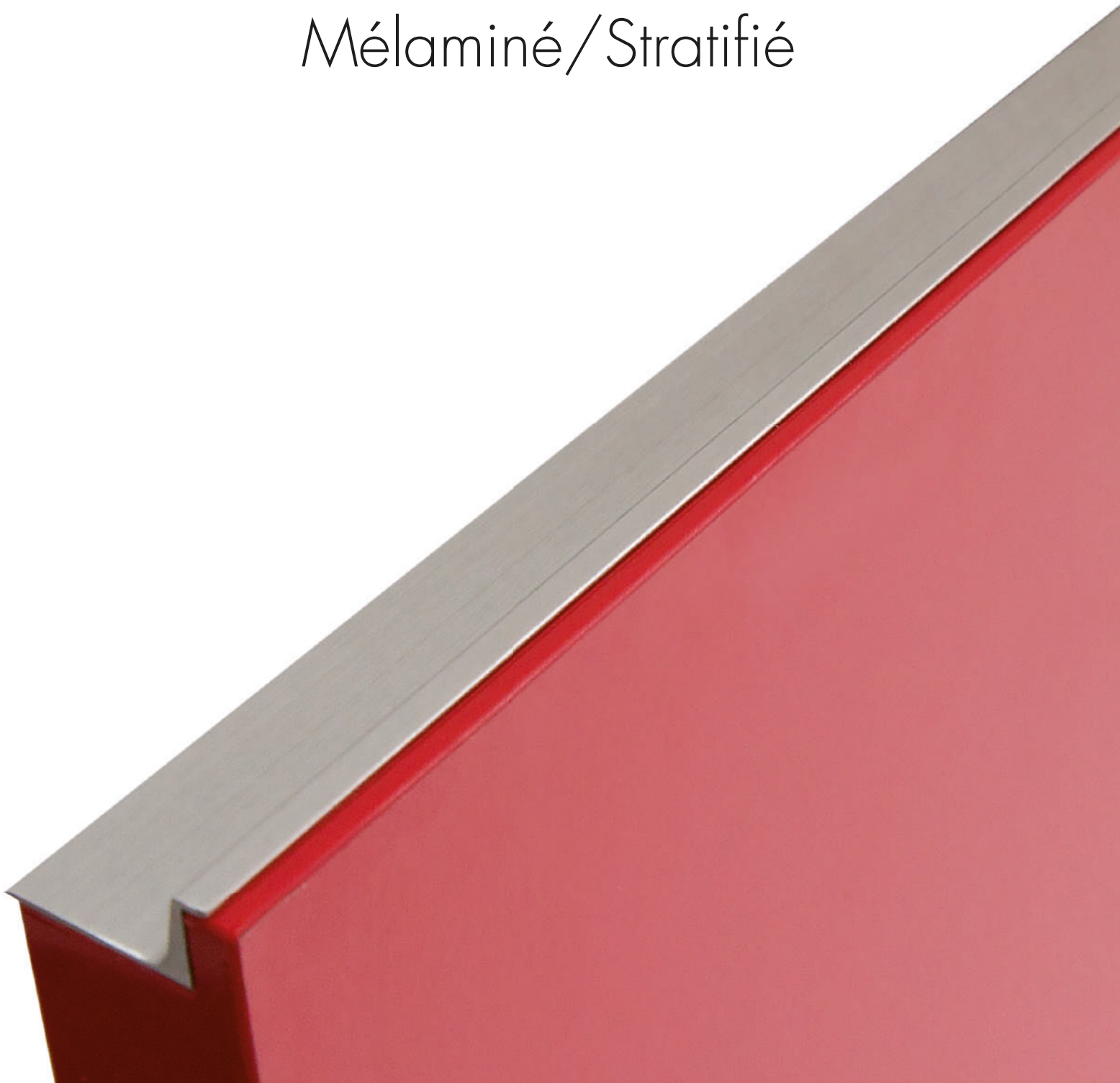

PLANET HALIFAX NATURAL / STUCCO BLANCO



LAMINADO LAMINATE MÉLAMINÉ/STRATIFIÉ

C1



Laminados: Tablero de partículas o MDF, recubierto de papeles decorativos tratados con resinas melamínicas. Puede ser de un color liso o llevar impreso un diseño de madera u otro material, además de distintas texturas (arenado, liso, seda). Presenta una terminación de canto en ABS, con sellado antihumedad y con colas de termofusión o PUR de última generación.

Estratificados: Tablero de partículas o MDF, recubierto de una chapa de estratificado. La chapa de diferentes grosores, que permite crear acabados brillo. Presenta una terminación de canto ABS, con sellado antihumedad y con colas de termofusión o PUR de última generación.

Laminates: Particle or MDF board covered with a decorative papers with melamine resins. It may be plain colours or design finishes, including different textures (sandy, smooth, silk). It presents a ABS finish with anti-humidity sealing and thermofusion glues or PUR (last generation glues).

Stratifieds: Particle or MDF board covered with a laminated veneer. Different sheet thicknesses wich allow to create gloss finishes. It presents a ABS finish with anti-humidity sealing and thermofusion glues or PUR (last generation glues).

Mé laminés: Panneaux de particules surfacés mélaminés ou MDF surfacés mélaminés. Différentes épaisseurs selon les modèles. Finitions lisse ou structurée ou soie. Coloris unis, mat et brillant. Coloris décor bois. Tous les chants sont plaqués (ABS). Collage à chaud par thermofusion ou collage avec colles PUR de dernière génération résistant à l'humidité.

Stratifiés: Panneaux de particules bruts ou MDF, revêtus d'une feuille de stratifié. Différentes épaisseurs selon les modèles. Finitions lisse ou structurée ou soie. Coloris unis, mat et brillant. Coloris décor bois. Tous les chants sont plaqués (ABS). Collage à chaud par thermofusion ou collage avec colles PUR de dernière génération résistant à l'humidité.



Tablero de partículas
Particle board
Panneaux de particules

Acabados en CPL y HPL
Finished in CPL & HPL
Finitions en mélaminé et stratifié

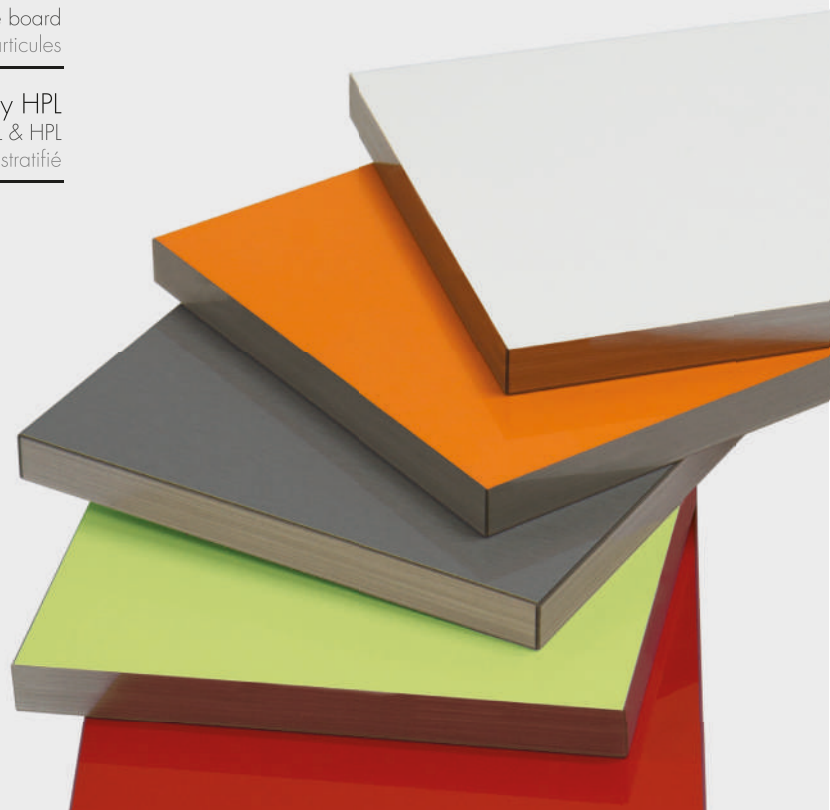

La terminación del canto en una puerta, representa la elegancia en su acabado final. El canto ABS es un termoplástico de alta calidad respetuoso con el medio ambiente.

The edge finish of a door, represents the elegance in its final finish. ABS is a thermoplastic high quality eco-friendly.

Les chants des portes principalement utilisés sont des chants thermoplastiques fabriqués en qualité ABS (acrylonitrile-butadiène-styrene) et sont teintés dans la masse.

A=ABS

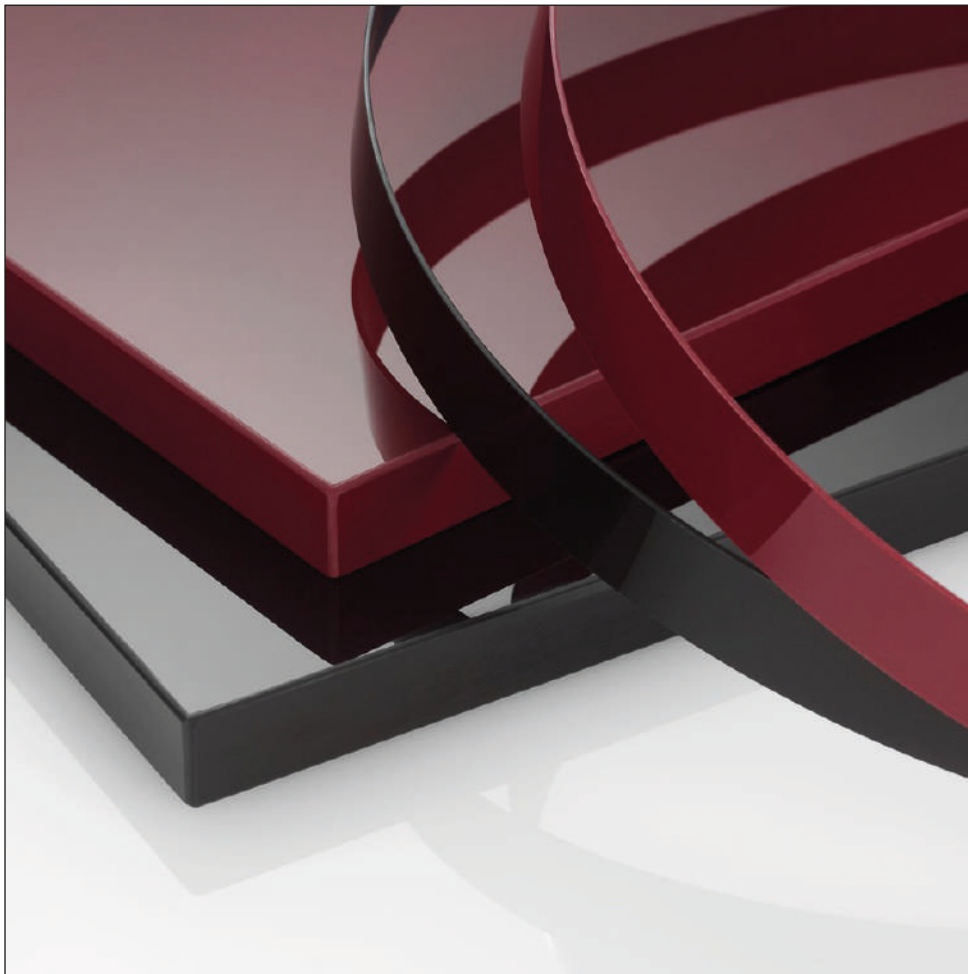

GAMA PLANET ARENADO

2 soluciones estéticas y 9 colores componen la innovadora colección Planet arenado 4C y 2V. Ofrecen una alternativa al postformado de baja presión, componiendo puertas de alta belleza estética con la opción en 3 piezas perfectamente ensambladas y canteadas. Con efecto arenado, en grosor de 19 mm. y con contracara diseño, son la elección adecuada para cualquier cocina.

2 aesthetic solutions and 9 colors make up the innovative sandy Planet 4C and 2V collection. It offers an alternative to low pressure postforming, composing high aesthetic beauty doors with the union of three pieces perfectly assembled and edged. With a sandy effect on thickness of 19 mm. and a design counterface, they are the right choice for every kitchen.

Panneau de particules surfacé MELAMINE, épaisseur 19 mm, 4 chants épais. Finition texturée. Contrebalancement identique à la façade.
2 formes de portes et 9 coloris composent la gamme PLANET ARENADO 4C (4 chants plaqués) et 2V (2 montants verticaux et un panneau central).



**BLANCO
ARENADO**

4C	LAM188
2V	LAM188-2V



**PINO
CASCINA**

4C	LAM169
2V	LAM169-2V



**FLEET
BLANCO**

4C	LAM162
2V	LAM162-2V

A=ABS

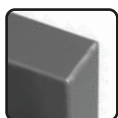

GAMA PLANET ARENADO



**FLEET
CHAMPÁN**

4C	LAM163
2V	LAM163-2V



**CASTAÑO
KENTUCKY**

4C	LAM16H
2V	LAM16H-2V



**ROBLE
BARDOLINO**

4C	LAM17G
2V	LAM17G-2V



**NOGAL
WARMIA**

4C	LAM16J
2V	LAM16J-2V



**CANADÁ
NATURAL**

4C	LAM19G
2V	LAM19G-2V



**CANADÁ
GRIS**

4C	LAM19F
2V	LAM19F-2V



GAMA PLANET LISO

2 soluciones estéticas y 7 colores componen la innovadora colección Planet 4C y 2V. Ofrecen una alternativa al postformado de baja presión, componiendo puertas de alta belleza estética con la opción en 3 piezas perfectamente ensambladas y canteadas. Con efecto liso, en grosor de 19 mm. y con contracara diseño, son la elección adecuada para cualquier cocina.

2 aesthetic solutions and 7 colors make up the innovative Planet 4C and 2V collection. It offers an alternative to low pressure postforming, composing high aesthetic beauty doors with the union of three pieces perfectly assembled and edged. With a smooth effect on thickness of 19 mm. and a design counterface, they are the right choice for every kitchen.

Panneau de particules surfacé MELAMINE, épaisseur 19 mm, 4 chants épais. Finition lisse. Contrebalancement identique à la façade. 2 formes de portes et 7 coloris composent la gamme PLANET LISSO 4C (4 chants plaqués) et 2V (2 montants verticaux et un panneau central).

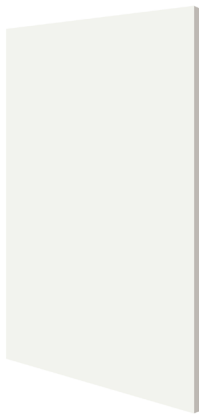

BLANCO

4C	LAM197
2V	LAM197-2V



BEIG ROSADO

4C	LAM198
2V	LAM198-2V



GRIS CACHEMIR

4C	LAM17H
2V	LAM17H-2V



GRIS CLARO

4C	LAM17K
2V	LAM17K-2V



GRIS CUBANITA

4C	LAM17M
2V	LAM17M-2V



CURRY

4C	LAM161
2V	LAM161-2V



VERDE NIAGARA

4C	LAM16C
2V	LAM16C-2V

A=ABS

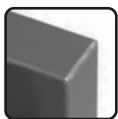

GAMA PLANET PORO PROFUNDO

2 soluciones estéticas y 4 colores componen la innovadora colección Planet 4C y 2V. Ofrecen una alternativa al postformado de baja presión, componiendo puertas de alta belleza estética con la opción en 3 piezas perfectamente ensambladas y canteadas. Con efecto arenado poro profundo, en grosor de 19 mm. y con contracara diseño, son la elección adecuada para cualquier cocina.

2 aesthetic solutions and 4 colors make up the innovative Planet 4C and 2V collection. It offers an alternative to low pressure postforming, composing high aesthetic beauty doors with the union of three pieces perfectly assembled and edged. With a sandy deep pore effect on thickness of 19 mm. and a design counterface, they are the right choice for every kitchen.

Panneau de particules surfacé MÉLAMINE, épaisseur 19 mm, 4 chants épais. Finition PORE PROFOND. Contrebalancement identique à la façade. 2 formes de portes et 4 coloris composent la gamme PLANET PORO PROFUNDO 4C (4 chants plaqués) et 2V (2 montants verticaux et un panneau central).



SIGMA NATURAL

4C	LAM18B
2V	LAM18B-2V



HALIFAX TABACO

4C	LAM16B
2V	LAM16B-2V



HALIFAX BLANCO

4C	LAM16E
2V	LAM16E-2V



HALIFAX NATURAL

4C	LAM16A
2V	LAM16A-2V

A=ABS

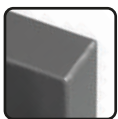

GAMA INNOVA 19

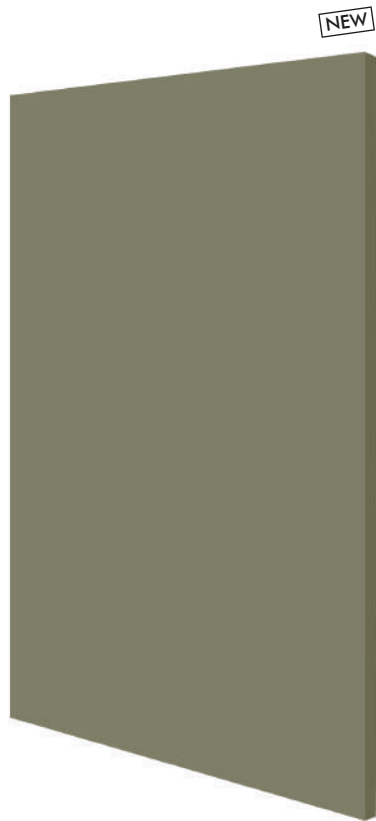

VERDE
CAMUFLAJE

Cod LAM151

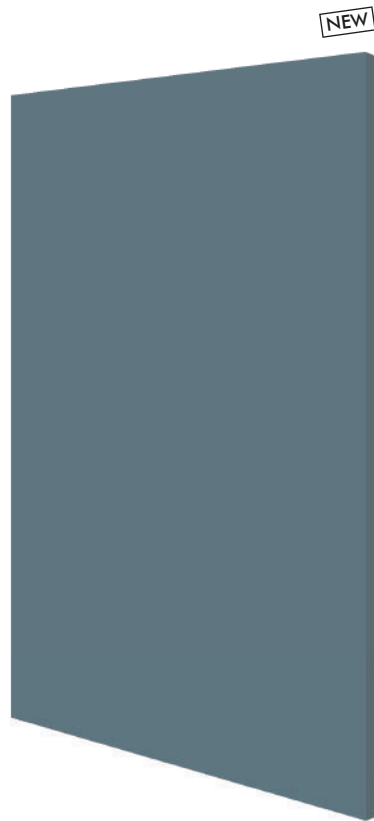

AZUL
TORMENTA

Cod LAM152

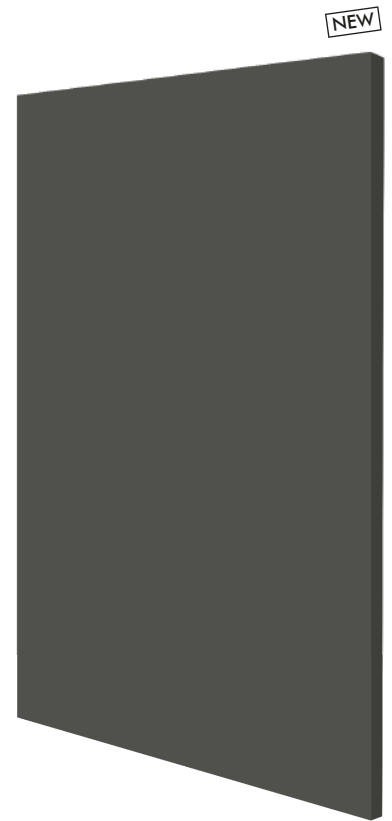

GRIS
ANTRACITA

Cod LAM153

A=ABS

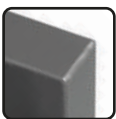



ARENA NEUTRO

Cod LAM154



PAPRIKA

Cod LAM155



STONE GRAFITO

Cod LAM156



STONE SAND

Cod LAM157



ELEGANCE OSCURO

Cod LAM15L



EXQUISITE TOSTADO

Cod LAM15M



EXQUISITE TABACO

Cod LAM15N



EXQUISITE NATURAL

Cod LAM15P



SUPREM BLANCO

Cod LAM15Q

GAMA MAX 1 BRILLO

Desarrollada en tablero de partículas con laminado alta presión y acabado en brillo a doble cara de 20 mm. La gama Max es la solución perfecta para ti y la estancia más cómoda de tu casa.

Developed in particles board with high pressure laminate and double sided gloss finish of 20 mm. The Max collection is the perfect solution for you to have a more comfortable home.

Panneau de particules STRATIFIE, épaisseur 20 mm, 4 chants épais. Finition BRILLANTE. Contrebalancement identique à la façade.



BLANCO

Cod LAM523



IRISH CREAM

Cod LAM52K



GRIS PLATA

Cod LAM52L



GRIS CENIZA

Cod LAM52O

A=ABS

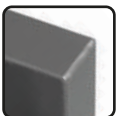

GAMA MAX 1 MATE

Desarrollada en tablero de partículas con laminado alta presión y acabado en mate a doble cara de 20 mm. La gama Max Mate es la solución perfecta para ti y la estancia más cómoda de tu casa.

Developed in particles board with high pressure laminate and double sided matt finish of 20 mm. The Max Matt collection is the perfect solution for you to have a more comfortable home.

Panneau de particules STRATIFIE, épaisseur 20 mm, 4 chants épais. Finition MAT. Contrebalancement identique à la façade.

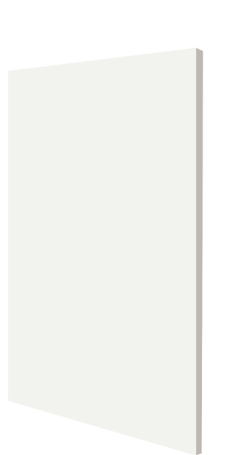

BLANCO

Cod LAM53B

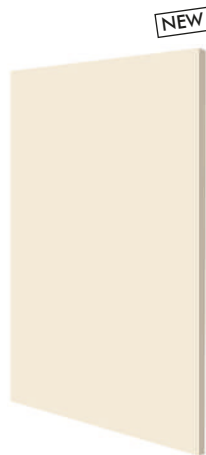

IRISH CREAM

Cod LAM53K



GRIS PLATA

Cod LAM53L



GRIS CENIZA

Cod LAM53O

A=ABS

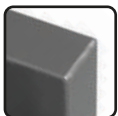

GAMA MAX 2 BRILLO

Desarrollada en tablero de partículas con laminado alta presión y acabado en brillo a doble cara de 20 mm. La gama Max es la solución perfecta para ti y la estancia más cómoda de tu casa.

Developed in particles board with high pressure laminate and double sided gloss finish of 20 mm. The Max collection is the perfect solution for you to have a more comfortable home.

Panneau de particules STRATIFIE, épaisseur 20 mm, 4 chants épais. Finition BRILLANTE. Contrebalancement identique à la façade.



NEGRO

Cod LAM529



BLANCO PURO

Cod LAM534



AZUL PACÍFICO

Cod LAM536

Nota: modelos nuevos incorporación Octubre 2022

Note: new models incorporation October 2022

Remarque: incorporation de nouveaux modèles en octobre 2022

A=ABS

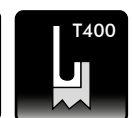
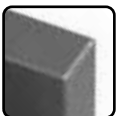



MENTA

Cod LAM537

NEW



COTTON

Cod LAM52J

NEW



AZUL COSTA

Cod LAM52D

NEW



AZUL MAR

Cod LAM52E

NEW



AZUL TROPICAL

Cod LAM52F

NEW



ROSA PASTEL

Cod LAM52U

NEW



MOSTAZA

Cod LAM52Q

NEW



ROSA CLARO

Cod LAM52T

NEW



MAQUILLAJE

Cod LAM52P



ANTRACITA

Cod LAM52C

GAMA MAX 2 MATE

Desarrollada en tablero de partículas con laminado alta presión y acabado en mate a doble cara de 20 mm. La gama Max Mate es la solución perfecta para ti y la estancia más cómoda de tu casa.

Developed in particles board with high pressure laminate and double sided matt finish of 20 mm. The Max Matt collection is the perfect solution for you to have a more comfortable home.

Panneau de particules STRATIFIÉ, épaisseur 20 mm, 4 chants épais. Finition MAT. Contrebalancement identique à la façade.



COTTON

Cod LAM53J



AZUL COSTA

Cod LAM53D



AZUL MAR

Cod LAM53E



AZUL TROPICAL

Cod LAM53F

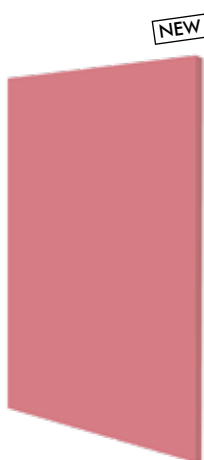

ROSA PASTEL

Cod LAM53U

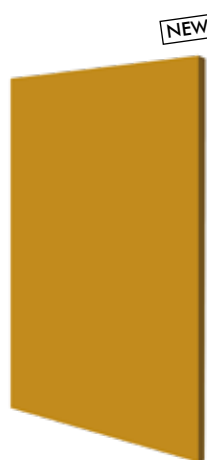

MOSTAZA

Cod LAM53Q

Nota: modelos nuevos incorporación Octubre 2022

Note: new models incorporation October 2022

Remarque: incorporation de nouveaux modèles en octobre 2022

A=ABS

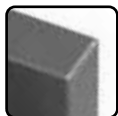

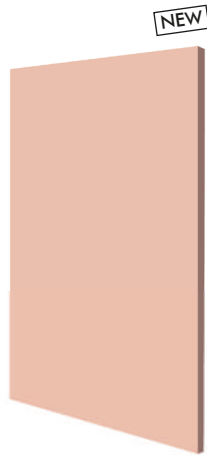

ROSA CLARO

Cod LAM53T

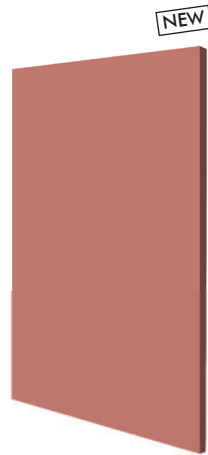

MAQUILLAJE

Cod LAM53P



ANTRACITA

Cod LAM53C

GAMA PET BRILLO

La gama PET es un producto polimérico ecológico prensado sobre tablero MDF de 18 mm. de grueso con contracara de melamina en su color. Se realiza en acabado Alto Brillo.

PET assortment is a latest generation product, made of ecologic polymer pressed on a panel of MDF 18 mm. thick with backside in its color. It's made in finish High Brightness.

Panneau MDF plaqué 1 face PET (Polyéthylène Téréphtalate - Polymère écologique et recyclable), épaisseur 18 mm, 4 chants épais. Il existe en 1 finition: BRILLANT. Contrebalancement en mélaminé de la même couleur que la façade.



BLANCO

Cod LAM55K

A=ABS

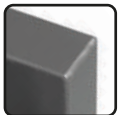

GAMA PET MATE

La gama PET es un producto polimérico ecológico prensado sobre tablero MDF de 18 mm. de grueso con contracara de melamina en su color. Se realiza en acabado Soft Mate, con colores lisos en diferentes tonalidades.

PET assortment is a latest generation product, made of ecologic polymer pressed on a panel of MDF 18 mm. thick with backside in its color. It's made in finish Soft Matte with solid colors in different tonalities.

Panneau MDF plaqué 1 face PET (Polyéthylène Téréphtalate - Polymère écologique et recyclable), épaisseur 18 mm, 4 chants épais. Il existe en finition Soft Mat. Contrebalancement en mélaminé de la même couleur que la façade.

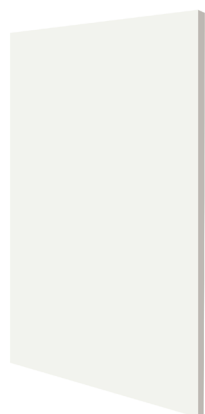

BLANCO

Cod LAM55A



GRIS OSTRÁ

Cod LAM55D



ANTRACITA

Cod LAM55C



NEW GREY

Cod LAM55E



NEGRO

Cod LAM55F

A=ABS

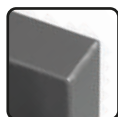

GAMA LUXOR

LUXOR es un material innovador creado para aplicaciones de diseño de interior, adecuado para múltiples aplicaciones. De alta resistencia, anti bacterias y con un acabado supermate anti huellas.

LUXOR is an innovative material created for interior design applications, suitable for multiple applications. Highly resistant, antibacterial and with a super matte anti-fingerprint finish.

LUXOR est un matériau innovant créé pour les applications de design d'intérieur, adapté à de multiples applications. Très résistant, antibactérien et avec une finition super mate anti-empreintes digitales.

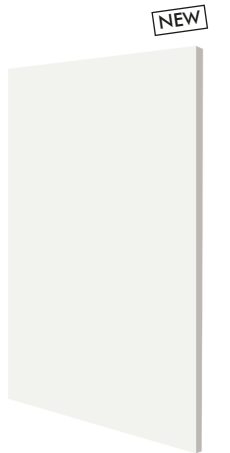

BLANCO 181LV

Cod LAM98A



NEGRO 106LV

Cod LAM98B



GRAFITO 139LV

Cod LAM98C



GRIS CLARO 159LV

Cod LAM98D



GRIS PIEDRA 151LV

Cod LAM98E

A=ABS

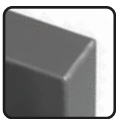

SEDA 	 20 mm	CONTRACARA LISA COLOR	AGLO 	 HPL	 305 130		 T400
 ANTIBACTERIA	 ANTI-HUELLA	 REFLECTANCIA	 ARAÑAZOS	 RESISTENCIA CALOR SECO	 RESISTENCIA DISOLVENTES	 TACTO SEDOSO	

FÉNIX AZUL NOCHE CON GRIS CLARO Y BLANCO 30



LAMINADO LAMINATE MÉLAMINÉ/STRATIFIÉ

C1



GAMA FÉNIX

FÉNIX NTM es un material innovador creado para aplicaciones de diseño de interior por ARPA Industriale, adecuado para aplicaciones tanto verticales como horizontales. La superficie exterior de FÉNIX NTM se obtiene con la aplicación de la nanotecnología y se caracteriza por una superficie decorativa tratada con resinas de nueva generación, resultado de la investigación de Arpa Industriale. FÉNIX NTM es adecuado para múltiples aplicaciones del diseño de interior: cocina, hostelería, sanidad, transportes, baños, muebles (mesas, estanterías, tabiques, sillas).

FÉNIX NTM is a innovative material created for interior design applications by Arpa Industriale. It is suitable for both vertical and horizontal use. The external surface of FÉNIX NTM involves the use of nanotechnology and its decor is obtained through next generation resins developed thanks to Arpa Industriale's research. FÉNIX NTM is suitable for different interior design applications: kitchens, hospitality, healthcare, transportation, bathrooms, furniture (tables, bookshelves, partitions, chairs).

Panneau de particules plaqué en STRATIFIE FÉNIX, épaisseur 20 mm, 4 chants épais. Finition MAT ANTI-TRACE. Contrebalancement en stratifié même coloris. 9 Coloris. FÉNIX NTM est un produit fabriqué par la société ARPA, grâce à un procédé utilisant la nanotechnologie. Il est anti-trace et les rayures se réparent.

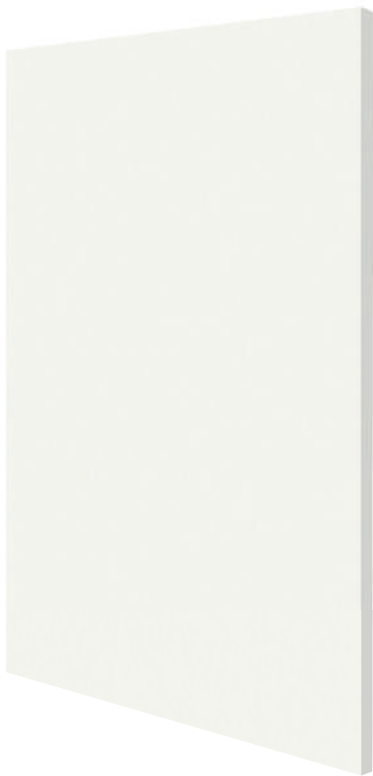

BLANCO
032

Cod LAM87A

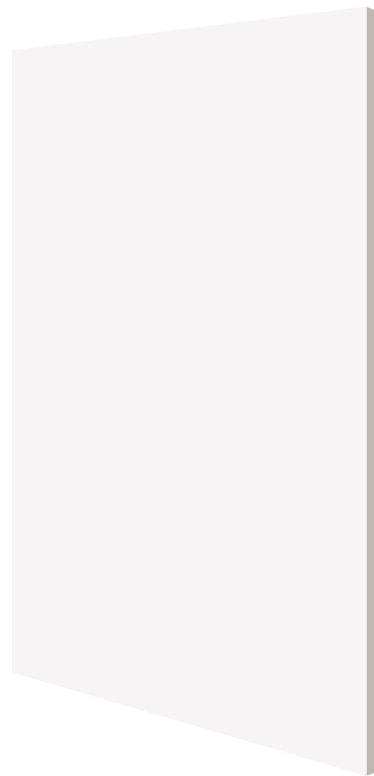

BLANCO ALASKA
030

Cod LAM87B

A=ABS

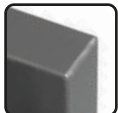

GAMA FÉNIX



TIERRA
717

Cod LAM87H

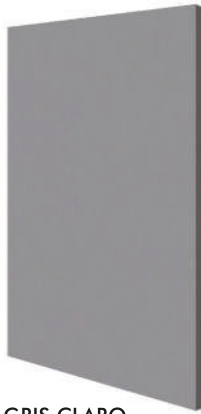

GRIS CLARO
725

Cod LAM87E



AZUL NOCHE
754

Cod LAM87K



GRIS TOPO
718

Cod LAM87F



GRAFITO
724

Cod LAM87D



ARIZONA
748

Cod LAM748



GRIS ATRIUM
752

Cod LAM752



VERDE
750

Cod LAM750



NEGRO
720

Cod LAM87G

GAMA FILM 22 VINTAGE

Les presentamos la nueva serie Vintage de la gama Film 22. Este muestrario representa pequeñas piezas del tablero original, y por tanto sólo es indicativa del color y estructura de la misma. 3 formas de puertas y 23 acabados en maderas nobles roble y nogal componen la gama.

- Forma standard: 4 cantos
- Forma VEGA: Biselado 45°
- Forma CALABRIA: Enmarcada con barras de 8 cm y panel central.

Los diseños en madera donde a la numeración le antecede la letra N, quiere decir que el diseño lleva nudos.

We present to you the new finishes Vintage of the Film 22 series. This sample is small parts of the original board, and thus only is indicative of the color and structure thereof. 3 forms of doors with 23 finished in hardwoods, oak and walnut compose the serie.

- Standard form: 4 edges
- VEGA form: bevelling 45°
- CALABRIA form: framed with 8cm bars and central panel.

All wood designs where the numbering is preceded by the letter N, mean design carries knots.

Panneau de particules surfacé MELAMINE, épaisseur 22 mm, 4 chants épais décor BOIS DE BOUT. Finition texturée. Décor bois chêne et noyer.

Contrebalancement identique à la façade.

3 formes de portes et 23 coloris composent la gamme FILM 22 VINTAGE.

- Forme standard: 4 chants plaqués
- Forme VEGA: Biseau 45°
- Forme CALABRIA: Encadrement et panneau central.

La référence "N" devant le numéro du coloris signifie qu'il s'agit d'un décor bois avec des noeuds.



3596 HAYA

Cod	LAM93J
Cod	LAM93JVG



CALABRIA S4671

Cod	LAM92Y
Cod	LAM92Y-4V
Cod	LAM92Y-VG

A=ABS

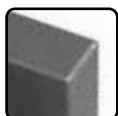

GAMA FILM 22 VINTAGE



NOGAL N. TURKANA

Cod	LAM93D
Cod	LAM93D-4V
Cod	LAM93D-VG



NOGAL N. NUBA

Cod	LAM92A
Cod	LAM92A-4V
Cod	LAM92A-VG



NOGAL N. TUAREG

Cod	LAM92B
Cod	LAM92B-4V
Cod	LAM92B-VG



NOGAL N. SAMBURU

Cod	LAM93C
Cod	LAM93C-4V
Cod	LAM93C-VG



N4677

Cod	LAM92T
Cod	LAM92T-4V
Cod	LAM92T-VG



N4675

Cod	LAM92N
Cod	LAM92N-4V
Cod	LAM92N-VG



S4569

Cod	LAM92W
Cod	LAM92W-4V
Cod	LAM92W-VG



N4673

Cod	LAM92L
Cod	LAM92L-VG



N4678

Cod	LAM92P
Cod	LAM92P-4V
Cod	LAM92P-VG



N4692

Cod	LAM92U
Cod	LAM92U-VG



N3822

Cod	LAM951
Cod	LAM951-VG



N3823

Cod	LAM952
Cod	LAM952-VG

GAMA FILM 22 VINTAGE



L0021

Cod	LAM956
Cod	LAM956-VG



L1049

Cod	LAM957
Cod	LAM957-VG



N4701

Cod	LAM92V
Cod	LAM92V-4V
Cod	LAM92V-VG



1423 SALVIA

Cod	LAM958
Cod	LAM958-4V
Cod	LAM958-VG



EUCALIPTO 3803

Cod	LAM953
Cod	LAM953-VG



EUCALIPTO 3804

Cod	LAM954
Cod	LAM954-VG



EUCALIPTO TINEO

Cod	LAM93K
Cod	LAM93K-VG



NOGAL ARGÁN

Cod	LAM93L
Cod	LAM93L-VG



FRESNO SAUPÉ

Cod	LAM93M
Cod	LAM93M-VG

GAMA FILM 22 SEDALAC

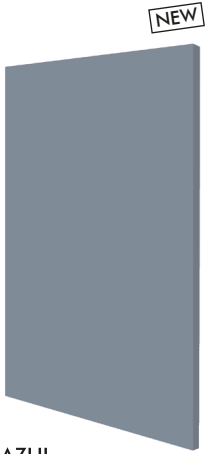

NEW

**AZUL
COLTAN**

Cod LAM970

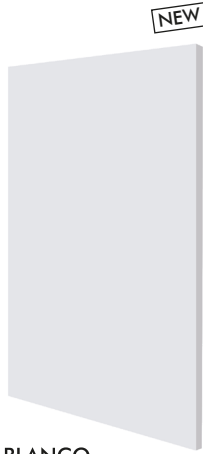

NEW

**BLANCO
ALGODÓN**

Cod LAM971

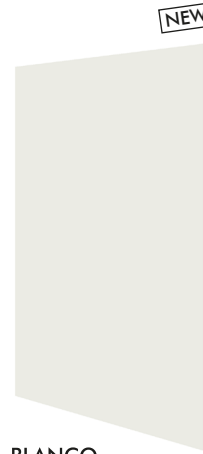

NEW

**BLANCO
CUERO**

Cod LAM972

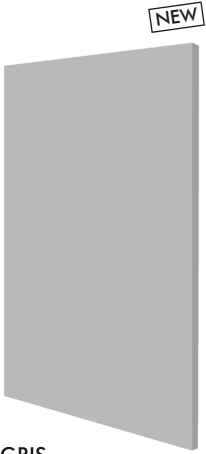

NEW

**GRIS
BRUMA**

Cod LAM973

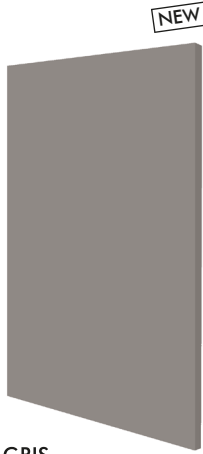

NEW

**GRIS
LLUVIA**

Cod LAM974



NEW

**GRIS
TÉNUE**

Cod LAM975

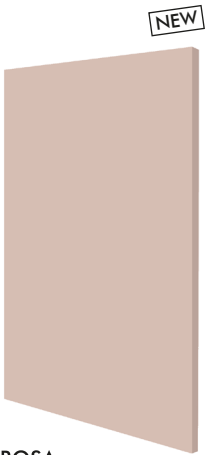

NEW

**ROSA
MELISA**

Cod LAM976

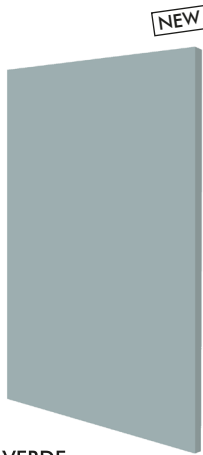

NEW

**VERDE
AGUA**

Cod LAM977



NEW

**VERDE
LAUREL**

Cod LAM978

A=ABS

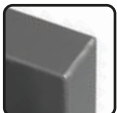

GAMA FILM 22 HAFAX



1180
NATURAL

Cod LAM927



1181
TABACO

Cod LAM928



1176
BLANCO

Cod LAM926

A=ABS

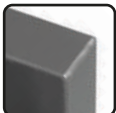

GAMA FILM 22 BRILLO

Les presentamos la nueva serie Brillo de la gama Film 22. Sus 5 tonos neutros en su acabado brillo, hacen esta gama muy agradable a la vista y al tacto. Nota importante: Contracara Melamina en su color.

We present to you the new Gloss of the Film 22 series. The five neutral tones in its gloss finish, make this range very pleasing to the touch and to the eyes. Important Note: Backside Melamine in its color.

Panneau de particules plaqué STRATIFIÉ, épaisseur 22 mm, 4 chants épais. Finition BRILLANT.
2 formes de portes sur certains coloris et 5 coloris. Contrebalancement en mélaminé même couleur que la façade.



BLANCO

Cod	LAM940
Cod	LAM940-VG



BEIG

Cod	LAM941
Cod	LAM941-VG



NUBE

Cod	LAM948
-----	--------



TERRA

Cod	LAM949
Cod	LAM949-VG



GRAFITO

Cod	LAM947
Cod	LAM947-VG

A=ABS

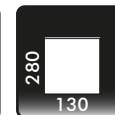
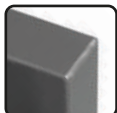

GAMA FILM 22 MATE

Les presentamos la nueva serie Mate de la gama Film 22. Sus 15 tonos neutros en su acabado mate, hacen esta gama muy agradable a la vista y al tacto. Nota importante: Contracara blanca para el color blanco y el resto de colores en melamina en su color.

We present you the new finishes Mate of the Film 22 series. The 15 neutral tones make this range very pleasing to touch and to see. Important note: White backside for the white colours and the rest of the colors in melamine in their color.

Panneau de particules plaqué STRATIFIÉ, épaisseur 22 mm, 4 chants épais. SUPER MAT. 15 coloris. Contrebalancement en mélaminé blanc pour la façade coloris blanc. Contrebalancement en mélamine de sa couleur pour tous les autres façades.

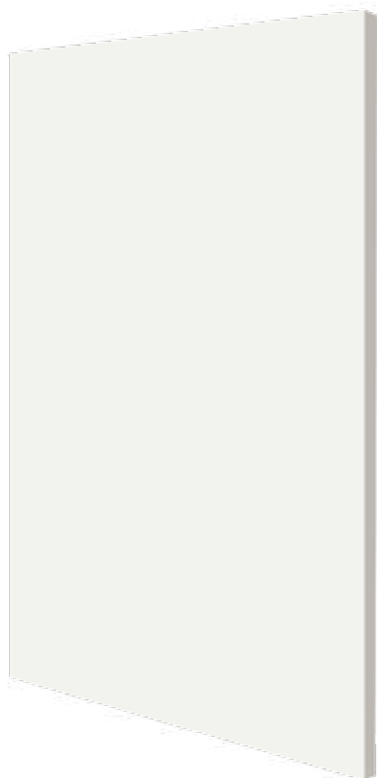

BLANCO

Cod	LAM930
Cod	LAM930-VG



CREMA

Cod	LAM931
Cod	LAM931-VG

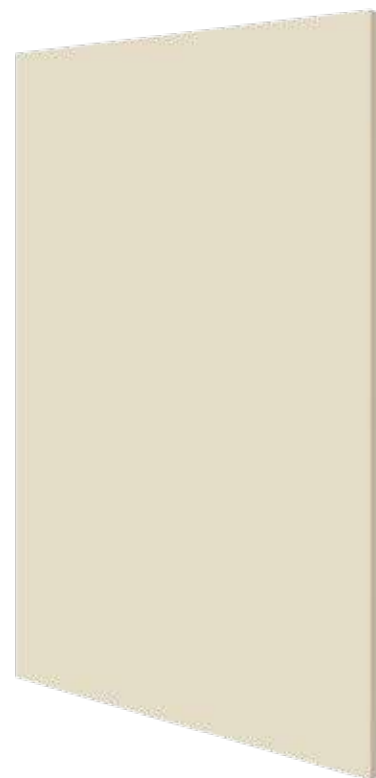

CAFÉ LATTE

Cod	LAM93A
Cod	LAM93A-VG

A=ABS

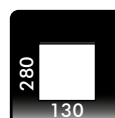
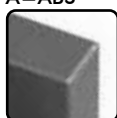

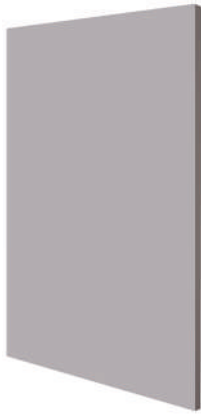

NUBE

Cod	LAM938
Cod	LAM938-VG



GRAFITO

Cod	LAM937
Cod	LAM937-VG



ROJO

Cod	LAM934
Cod	LAM934-VG

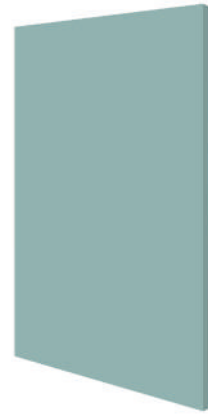

AGUAMARINA

Cod	LAM939
Cod	LAM939-VG



CAPUCHINO

Cod	LAM936
Cod	LAM936-VG



NEGRO

Cod	LAM932
Cod	LAM932-VG



AZUL ROYAL

Cod	LAM93L
Cod	LAM93L-VG



VERDE FOREST

Cod	LAM93K
Cod	LAM93K-VG



TALCO

Cod	LAM93M
Cod	LAM93M-VG



NUEZ

Cod	LAM93H
Cod	LAM93H-VG



GRIS KOALA

Cod	LAM93F
Cod	LAM93F-VG



HUMMUS

Cod	LAM93G
Cod	LAM93G-VG

GAMA FILM 22 VINTAGE PALMA



N 4675

Cod LAM92N-P



N 4677

Cod LAM92T-P



NOGAL N. TURKANA

Cod LAM93D-P



NOGAL N. TUAREG

Cod LAM92B

NOTA / NOTE

GAMA FILM 22 VINTAGE

Solo Veta vertical / Only vertical vein / Veine verticale unique
Altura Máxima / Maximum height / Hauteur maximale 130 cm.



EUCALIPTO TINEO

Cod LAM93K



NOGAL ARGÁN

Cod LAM93L

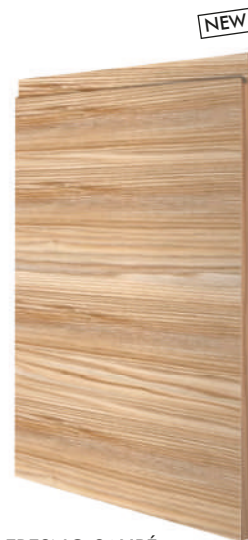

FRESNO SAUPÉ

Cod LAM93M

NOTA / NOTE

GAMA FILM 22 VINTAGE

Solo Veta horizontal / Only horizontal vein / Veine horizontal unique
Altura Máxima / Maximum height / Hauteur maximale 130 cm.

A=ABS

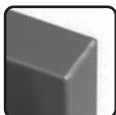

GAMA FILM 22 HAFAX PALMA



1080
NATURAL

Cod LAM927-P



1081
TABACO

Cod LAM928-P



1176
BLANCO

Cod LAM926-P

NOTA / NOTE

GAMA FILM 22 HAFAX PALMA

Solo Veta horizontal / Only horizontal vein / Veine horizontal unique
Altura Máxima / Maximum height / Hauteur maximale 130 cm.

A=ABS

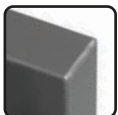

GAMA FILM 22 MATE PALMA

Nueva incorporación de puertas con tirador integrado que nos permiten un diseño de cocinas con líneas rectas y totalmente actuales. Con diferentes acabados: un brillo y diez mates, lo que nos permite un gran número de diseños y combinaciones.

New incorporation of doors with integrated handle that allow us to design kitchens with straight lines and totally current. With different finishes: one gloss and ten matt, which allows us a large number of designs and combinations.

Nouvelle incorporation de façades avec poignée intégrée qui permettent un design de cuisines avec lignes droites et actuelles. Avec différentes finitions: une brillante et dix mates. Cela permet un grand nombre de designs et combinaisons.



BLANCO

Cod LAM930P



CAFÉ LATTE

Cod LAM93AP



CREMA

Cod LAM931P



NUBE

Cod LAM938P



GRAFITO

Cod LAM937P



NEGRO

Cod LAM932P



VERDE FOREST

Cod LAM93K-P

A=ABS

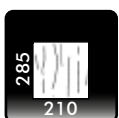
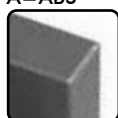

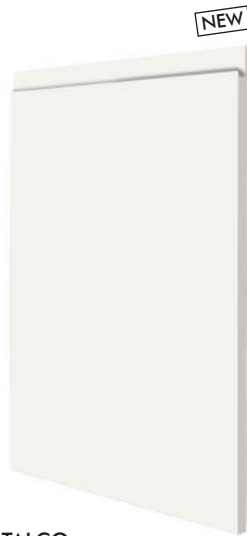

TALCO

Cod LAM93MP

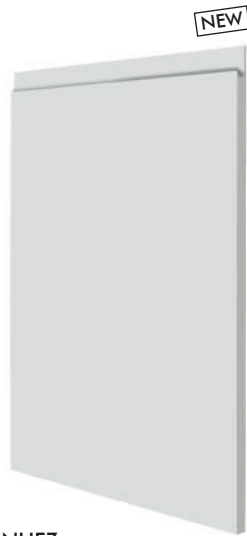

NUEZ

Cod LAM93HP

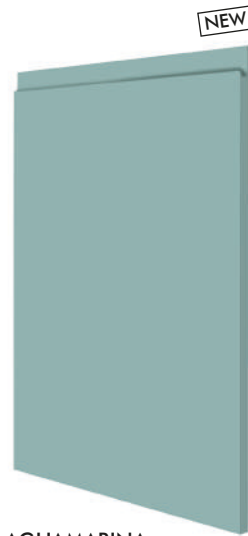

AGUAMARINA

Cod LAM939P

GAMA FILM 22 BRILLO PALMA



BLANCO

Cod LAM940P

NOTA / NOTE

GAMA FILM 22 Brillo
Altura Máxima / Maximum height
Hauteur maximale
130 cm.

A=ABS

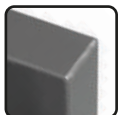

COMPLEMENTOS COMPLEMENTS COMPLEMENTS

REGLETA / CORNILUZ

FILLERS / CORNISE-PELMET | FILLEUR / CORNICHE-ÉCLAIRAGE



Para medidas consultar Gama.
To consult measures Gama.
Dimensions selon modèles.

Cod.
141 + Cod. Mod.

ZÓCALO

PLINTH | SOCLE



Para medidas consultar Gama.
To consult measures Gama.
Dimensions selon modèles.

Cod.
149 + Cod. Mod.

TERMINAL ALTO / SOBRE ENCIMERA

TALL TERMINAL / WORKTOP | HAUT TERMINAL / SUR COMPTOIR



			Cod.	
a†	b	c	150 + Cod. Mod.	
70	30	35	70	xx
80	30	35	80	xx
90	30	35	90	xx
130	30	35	130	xx
145	30	35	145	xx

TERMINAL BAJO / S. COLUMNA / COLUMNA

BASE TERMINAL / S.COLUMNS / COLUMN | BAS TERMINAL / S. COLONNE / COLONNE



			Cod.	
a†	b	c	151 + Cod. Mod.	
70	30	60	70	xx
80	30	60	80	xx
90	30	60	90	xx
145	30	60	145	xx
215	30	60	215	xx
235	30	60	235	xx

BOTELLERO COLMENA

HIVE BOTTLE HOLDER | CASIER À BOUTEILLES RUCHE



		Cod.	
a†	b	161 + Cod. Mod.	
45	30	4530	xx
45	45	4545	xx
45	60	4560	xx
45	90	4590	xx
70	15	7015	xx
70	30	7030	xx
70	45	7045	xx
70	60	7060	xx
80	15	8015	xx
80	30	8030	xx
80	45	8045	xx
80	60	8060	xx
90	15	9015	xx
90	30	9030	xx
90	45	9045	xx
90	60	9060	xx

DECORATIVO

DECORATIVE | NICHES OUVERTES COLORIS FACADE HORIZONTALES ET VERTICALES



			Cod.	
			160 + Cod. Mod.	
			170 + Cod. Mod.	
a†	b	c		
45	30	35	4530	xx
45	45	35	4545	xx
45	60	35	4560	xx
45	90	35	4590	xx
70	15	35	7015	xx
70	30	35	7030	xx
70	45	35	7045	xx
70	60	35	7060	xx
80	15	35	8015	xx
80	30	35	8030	xx
80	45	35	8045	xx
80	60	35	8060	xx
90	15	35	9015	xx
90	30	35	9030	xx
90	45	35	9045	xx
90	60	35	9060	xx



			Cod.	
			160 + Cod. Mod.	
			170 + Cod. Mod.	
a†	b	c		
45	30	60	453060	xx
45	45	60	454560	xx
45	60	60	456060	xx
45	90	60	459060	xx
70	15	60	701560	xx
70	30	60	703060	xx
70	45	60	704560	xx
70	60	60	706060	xx
80	15	60	801560	xx
80	30	60	803060	xx
80	45	60	804560	xx
80	60	60	806060	xx
90	15	60	901560	xx
90	30	60	903060	xx
90	45	60	904560	xx
90	60	60	906060	xx





BOB
COCINAS

Laminado
Laminate
Mélaminé/Stratifié

la base
de la cocina

BC3
COCINAS

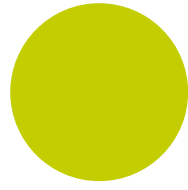

Postformado
Postforming
Postformage





POSTFORMADO POSTFORMING POSTFORMAGE

ENCIMERAS WORKTOPS PLANS DE TRAVAIL

CARACTERÍSTICAS GENERALES / GENERAL CHARACTERISTICS / CARACTÉRISTIQUES GÉNÉRALES

Tablero de partículas recubierto en ambas caras y postformado con papeles decorativos tratados con resinas melamínicas. Puede ser de un color liso o llevar impreso un diseño de madera u otro material, además de distintas texturas (arenado, liso, seda...). Presenta una terminación de 2 cantos, con sellado antihumedad y con colas de termofusión de última generación.

Particles board coated on both sides and postforming decorative paper treated with melamine resins. It can be a solid color or a printed wood desing or other material, in addition to different textures (sandblasted, smooth, silk...). Presents a 2 edges finish, moisture sealed and thermofusion glues of last generation.

Panneaux de particules recouvert des deux côtés et postformage avec papiers décoratifs traités et des résines melaminée peut être d'une couleur unie ou désign de report imprimé en bois ou autre matériau, en plus de différentes textures (sablé, lisse, soie...). Présente de una terminaison de 2 bords humidité seellés avec des colles thermofusibles dernière génération.

ENCIMERAS POSTFORMADAS

POSTFORMING WORKTOPS
PLAN DE TRAVAIL PORFORMAGE

$\frac{b}{360}$	$\frac{c}{62}$
-----------------	----------------

MOSTRADORES POSTFORMADOS

POSTFORMING COUNTER
CONTRER PORFORMAGE

$\frac{b}{360}$	$\frac{c}{0-65}$
$\frac{b}{360}$	$\frac{c}{65-90}$
$\frac{b}{360}$	$\frac{c}{90-110}$



Tablero de partículas de laminado de alta presión y postformado a uno o dos lados. Presenta perfil de radio 4 mm.

Chipboard panel covered in HPL according to the designs. Presents profile with radius of 4 mm.

Agloméré de particules laminé en haute pression selon modèles. Présente un profil de radio 4 mm.

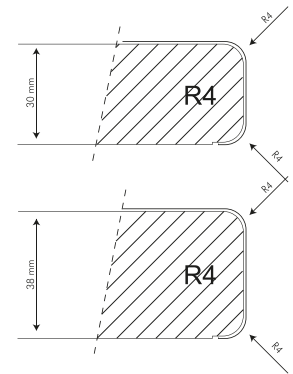

TIRA DE CANTEO | EDGING STRIP | BANDE DE BORDURE



$\frac{b}{360}$	Cod.
	845801

ENCIMERAS WORKTOPS PLANS DE TRAVAIL - **30 MM**



ALUMINIO MATE
R4 30MM

Encimera Worktop Plan de travail	Cod
↔ 360	290001
Mostrador Counter Contre	
360	291001



BLANCO MATE
R4 30MM

Encimera Worktop Plan de travail	Cod
↔ 360	290041
Mostrador Counter Contre	
360	291041



AURORA NATURAL
R4 30MM

Encimera Worktop Plan de travail	Cod
↔ 360	290004
Mostrador Counter Contre	
360	291004

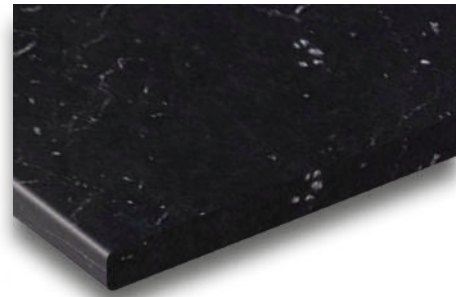

NEGRO ZEUS
R4 30MM

Encimera Worktop Plan de travail	Cod
↔ 360	290521
Mostrador Counter Contre	
360	291521



PIEDRA NEGRA
R4 38MM

Encimera Worktop Plan de travail	Cod
↔ 360	290742
Mostrador Counter Contre	
360	290742



PIEDRA BLANCA
R4 38MM

Encimera Worktop Plan de travail	Cod
↔ 360	290741
Mostrador Counter Contre	
360	290741

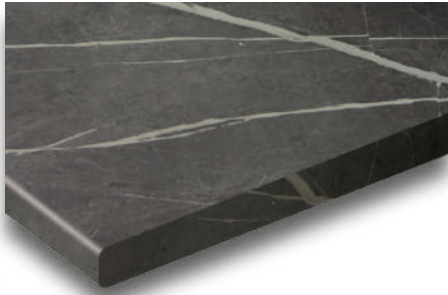

MÁRMOL GRAPHITE
R4 38MM

Encimera Worktop Plan de travail		
↔	Cod	
360	29074A	
Mostrador Counter Contre		
360	29074A	



MÁRMOL BEIGE
R4 38MM

Encimera Worktop Plan de travail		
↔	Cod	
360	290748	
Mostrador Counter Contre		
360	291748	



MÁRMOL CALACATTA
R4 38MM

Encimera Worktop Plan de travail		
↔	Cod	
360	290749	
Mostrador Counter Contre		
360	291749	



CEMENTO GRIS
R4 38MM

Encimera Worktop Plan de travail		
↔	Cod	
360	290747	
Mostrador Counter Contre		
360	291747	



NOBLE CASTAÑO
R4 38MM

Encimera Worktop Plan de travail		
↔	Cod	
360	290756	
Mostrador Counter Contre		
360	290756	



NEW

STONE SAND
R4 38MM

Encimera Worktop Plan de travail	Cod
← 360	290693
Mostrador Counter Contre	
360	290693

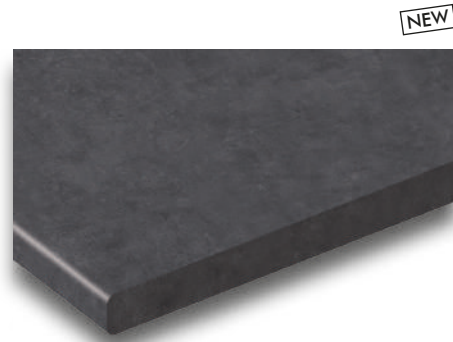

NEW

STONE GRAFITO
R4 38MM

Encimera Worktop Plan de travail	Cod
← 360	290694
Mostrador Counter Contre	
360	290694



NEW

HALIFAX TABACO
R4 38MM

Encimera Worktop Plan de travail	Cod
← 360	290284
Mostrador Counter Contre	
360	290284



NEW

HALIFAX BLANCO
R4 38MM

Encimera Worktop Plan de travail	Cod
← 360	290285
Mostrador Counter Contre	
360	290285



NEW

HALIFAX NATURAL
R4 38MM

Encimera Worktop Plan de travail	Cod
← 360	290283
Mostrador Counter Contre	
360	290283

ENCIMERAS COMPACTO WORKTOPS COMPACT PLANS DE TRAVAIL COMPACT - 12 MM



BLANCO
12MM

Encimera | Worktop | Plan de travail
←→ **Cod**
305 295001

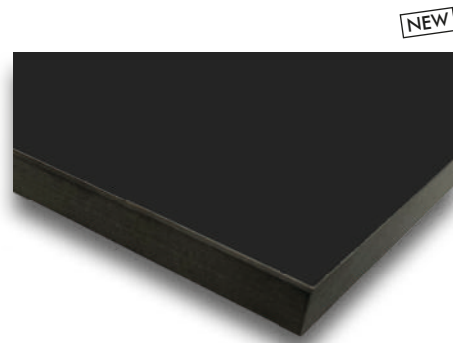

NEGRO
12MM

Encimera | Worktop | Plan de travail
←→ **Cod**
305 295002

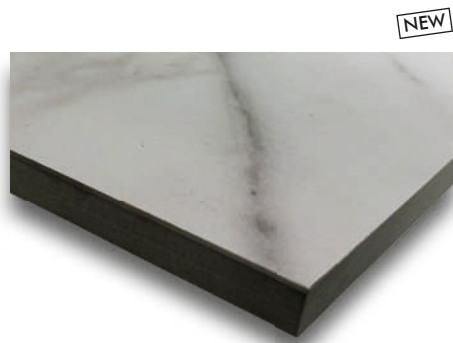

MÁRMOL BRECCIA
12MM

Encimera | Worktop | Plan de travail
←→ **Cod**
305 295003

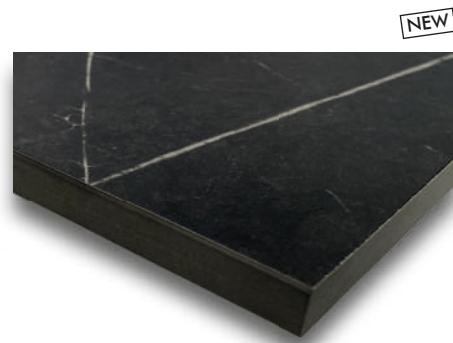

MÁRMOL MARQUINA
12MM

Encimera | Worktop | Plan de travail
←→ **Cod**
305 295004

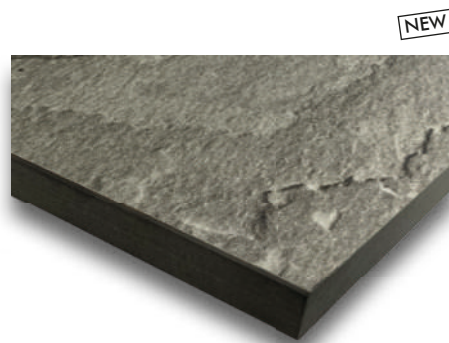

MÁRMOL MATTERHORN
12MM

Encimera | Worktop | Plan de travail
←→ **Cod**
305 295005

BC3
COCINAS



Postformado
Postforming
Postformage



el gusto
por las formas



BC3
COCINAS

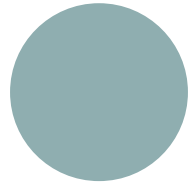

Polilaminado
Polilaminate
Polymère



TRENTO F87 NUDOS / F80 GRIS MEDIO / MALLORCA PIEDRA GRAFITO



POLILAMINADO POLILAMINATE POLYMÈRE



Polilaminado (policloruro de vinilo): Es un material plástico de recubrimiento moldeable, que tiene la propiedad de adaptarse muy bien a las formas más complejas. Se utiliza como recubrimiento en puertas de MDF, pudiendo ser las puertas con forma. El MDF (o DM) es fibra de madera prensada, que se puede fresar y tallar. Un DM recubierto de PVC es prácticamente inalterable al agua. Posibilidad de colores lisos o imitaciones de madera. La contratara se recubre con melamina blanca o diseño, según modelo, existiendo también la posibilidad de lacar la contracara en un color liso imitando al folio (consultar esta opción).

Poly laminate (Polyvinyl chloride) is a moldable plastic coating, which has the ability to adapt well to the more complex forms. It is used as a coating on MDF doors, the doors can be shaped. MDF (or DM) is pressed wood fiber, which can be milled and carved. A base of MDF covered with PVC is practically water unchanged. Possibility of solid colors or imitation wood finish. The back side is coated with white or design melamine depending on the model, there is also the possibility of lacquer the other side in a solid color imitating sheet (see this option).

Le Polymère (polychlorure de vinyle) est un revêtement thermoplastique pouvant être moulé à tout type de forme de façade. Les panneaux de support sont en MDF (panneau de fibres de moyenne densité) ce qui permet de reproduire tout type de forme de porte, car il se travaille comme le bois massif. De nombreux coloris sont proposés: mat, brillant, décor bois, texturés, etc. Il y a 8 coloris de contrebalancement mélaminé aux choix, sans supplément de de prix. Possibilité de contrebalancer avec laque ou polymère identique à la façade, avec supplément.



MDF



FOLIO POLILAMINADO
POLYLAMINATE SHEET / FEUILLE EN POLYLAMINÉ

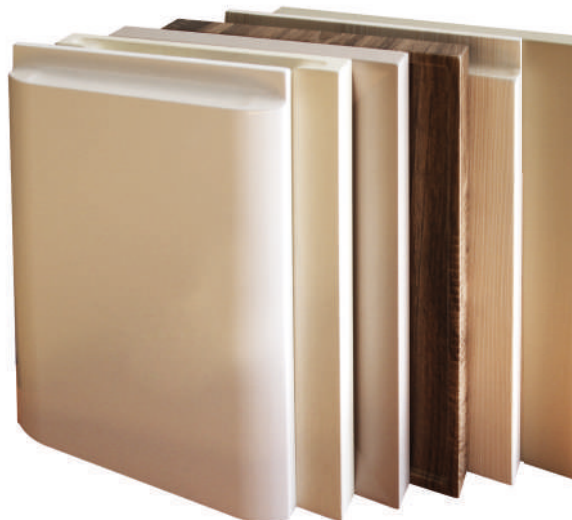

PUERTA POLILAMINADO
POLYLAMINATE DOOR / PORTE EN POLYLAMINÉ

ACABADOS / FINISHES / FINITIONS



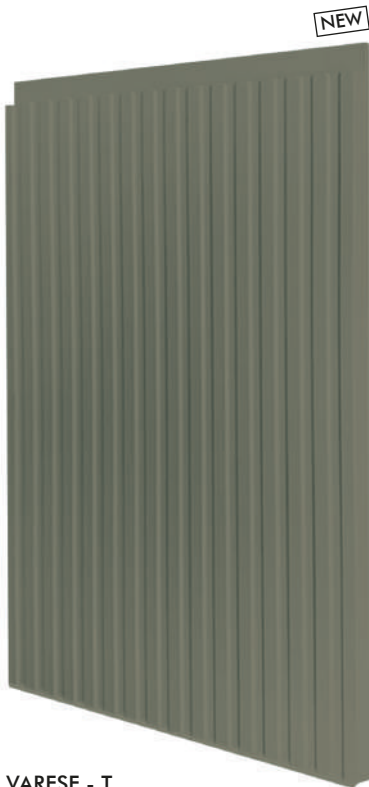

VARESE - T
F93 VERDE PASTEL

Cod	POL809T
↓	22MM



VARESE
F95 AZABACHE

Cod	POL809
↓	22MM



ONDAS 2,5 CM
F92 CALACATTA

Cod	POL571
↓	22MM



ONDAS 1 CM
F90 HALIFAX NATURAL

Cod	POL572
↓	22MM



VANCOUVER
F78 BLANCO POLAR SEDA

Cod	POL808
↓	22MM



GRÉCIA
F58 OLIVA FRESNO

Cod	POL244
↓	22MM



ALFA
F59 BLANCO FRESNO

Cod	POL009
↓	22MM



DOHA
F61 NUEVO WENGUÉ

Cod	POL127
↓	22MM

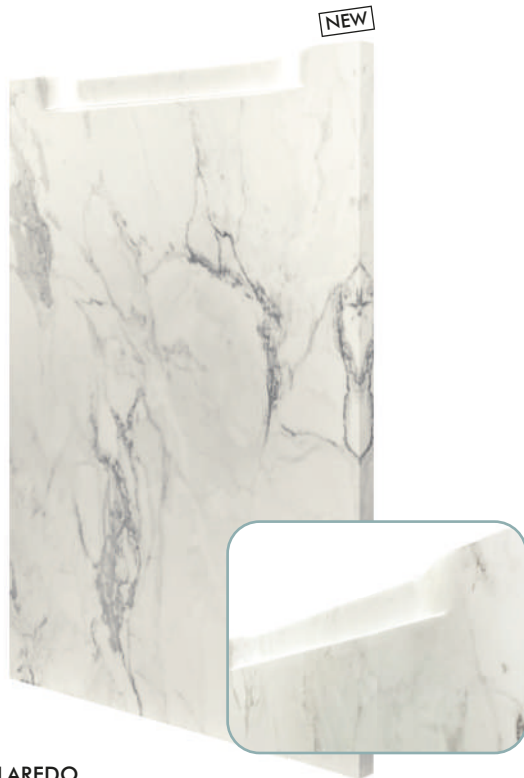

LAREDO
F92 CALACATTA

Cod	POL444
	22MM



RODAS
F305 SOMBRA

Cod	POL644
	22MM



ORLANDO
F69 ARENA CLARO MULTIPUNTO

Cod	POL562
	22MM



TRÍPOLI
F78 BLANCO POLAR SEDA

Cod	POL802
	22MM



VOLGA
F68 BLANCO ROTO MULTIPUNTO

Cod	POL804
↑ ↓	19MM



DOMO
F70 GRIS CLARO

Cod	POL128
↑ ↓	22MM



FLORENCIA
F76 NOGAL RINALDI

Cod	POL302
↑ ↓	22MM



PARÍS
F75 TEKA ANTIQUE

Cod	POL608
↑ ↓	22MM

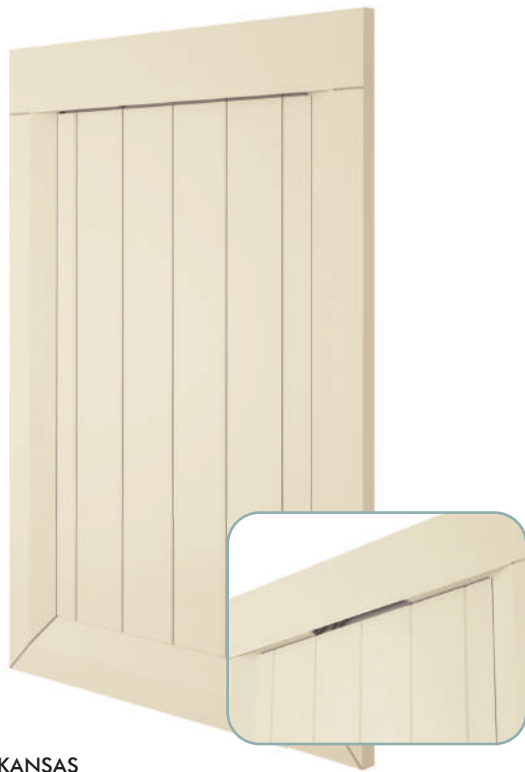

KANSAS
F56 NIGÚ SEDA

Cod	POL401
	22MM



MAELLA
T2 F60 CREMA FRESNO

Cod	POL482
	19MM



VILANOVA
F69 ARENA CLARO MULTIPUNTO

Cod	POL805
	22MM



ALZIRA
F58 OLIVA FRESNO

Cod	POL010
	22MM



VERA
F70 GRIS CLARO

Cod	POL806
↑ ↓	22MM



NUBE
F33 BLANCO ALTO

Cod	POL523
↑ ↓	22MM



AMBERES
F86 NUDOS
SINCRONIZADO BLANCO

Cod	POL002
↑ ↓	19MM



RÓDANO
F4 BLANCO SOFT

Cod	POL642
↑ ↓	19MM



XÁTIVA
F52 CREMA SEDA

Cod	POL0841
↑ ↓	22MM



MONTREAL
F36 CREMA ALTO

Cod	POL488
↑ ↓	22MM



CRONOS
F75 TEKA ANTIQUE

Cod	POL084
↑ ↓	22MM

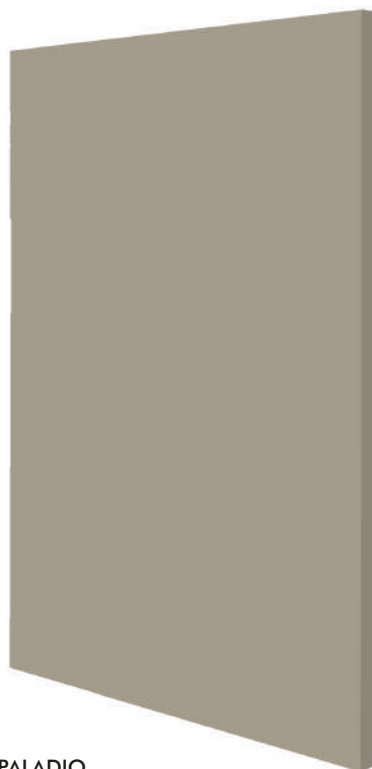

PALADIO
F71 STONE

Cod	POL601
↑ ↓	19MM



MÁLAGA
F72 TRUFFLE

Cod	POL483
↑ ↓	19MM



TRENTO
F67 PET ENTABLILLADO OSCURO

Cod	POL726
↑ ↓	22MM

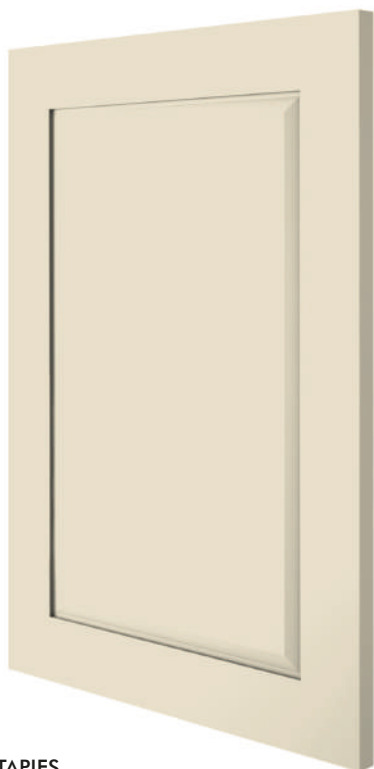

TAPIÉS
F56 NIGÚ SEDA

Cod	POL727
↑ ↓	19MM



SINTRA RECTA
F51 BLANCO SEDA

Cod	POL686
↑ ↓	19MM



BALTIMORE
F69 ARENA CLARO MULTIPUNTO

Cod	POL043
↓	22MM

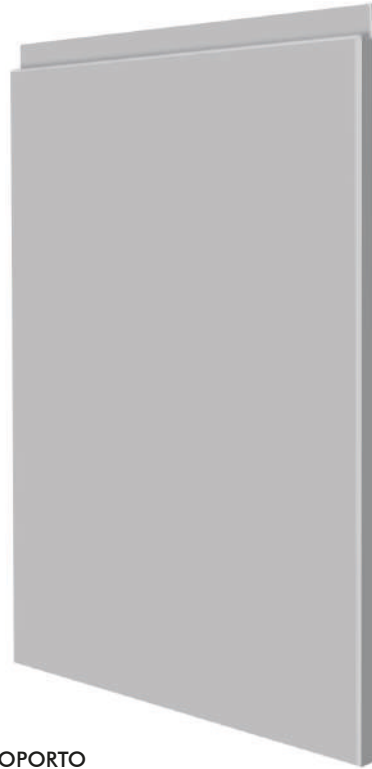

OPORTO
305 SOMBRA

Cod	POL563
↓	22MM



FOLIOS FOIL FEUILLE

MATE / MATTE / MAT

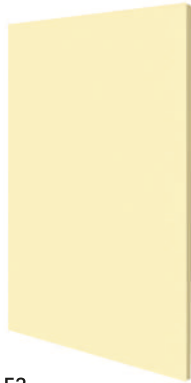

F3
AMARILLO SOFT

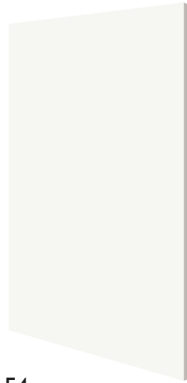

F4
BLANCO SOFT

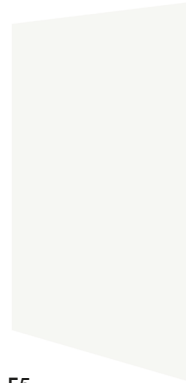

F5
BLANCO FRESNO



F6
CREMA



F20
NOGAL



F23
NOGAL NUEVO



F29
ALUMINIO



F51
BLANCO SEDA

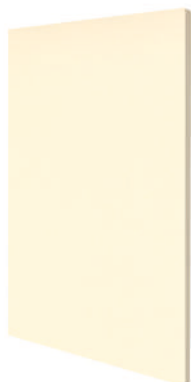

F52
CREMA SEDA



F53
GRIS SEDA



F56
NIGÚ SEDA



F57
ROBLE RÚSTICO



F58
OLIVA FRESNO



F59
BLANCO FRESNO



F60
CREMA FRESNO



F61
NUEVO WENGUÉ

FOLIOS FOIL FEUILLE



F62
BLANCO PROFUNDO



F63
ROBLE METAL



F68
BLANCO ROTO
MULTIPUNTO



F69
ARENA CLARO
MULTIPUNTO



F70
GRIS CLARO



F71
STONE



F72
TRUFFLE



F73
AZUL NOVA



F74
AZUL ÍNDICO



F75
TEKA ANTIQUE

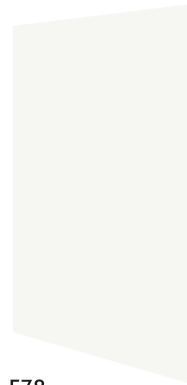

F78
BLANCO POLAR SEDA



F79
AZUL CLARO SEDA



F80
GRIS MEDIO
MULTIPUNTO



F85
CEMENTO OSCURO



F86
NUDOS
SINC. BLANCO



F87
NUDOS
SINC. NATURAL

FOLIOS FOIL FEUILLE



F88
ROBLE DECAPÉ



F89
HALIFAX BLANCO



F90
HALIFAX NATURAL



F91
HALIFAX TABACO



F92
CALACATTA



F93
VERDE PASTEL



F94
GRIS IGNEO



F95
AZABACHE



F96
NUIT

FOLIOS FOIL FEUILLE

MATE ANTI-HUELLA / ANTI-FINGERPRINT MATT / MAT ANTI-EMPREINTES

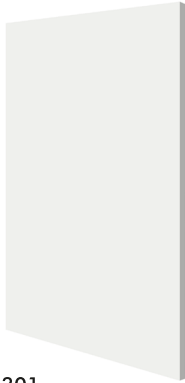

301
NIEBLA

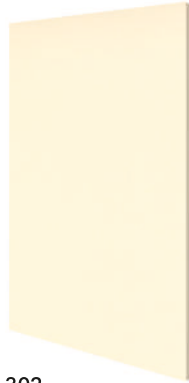

302
MARFIL



304
LONA



305
SOMBRA



306
BASALTO



307
NOCHE



308
TAUPE



309
GREDA



310
HABANA



311
ENEBRO

FOLIOS FOIL FEUILLE

BRILLO / GLOSS / BRILLANT



F34
NEGRO



F35
ROJO



F36
CREMA



F37
BERENJENA



F64
PET CAPUCHINO



F33
BLANCO



F82
GRIS CLARO



F83
GRIS OSCURO

CONTRACARAS BACK SIDE CONTREBALANCEMENT

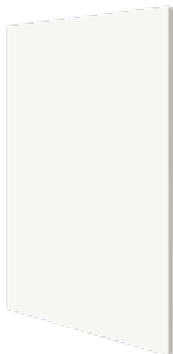

BLANCO 19/22 mm



ALUMINIO 19/22 mm



GRAFITO 19/22 mm



CEREZO 19 mm

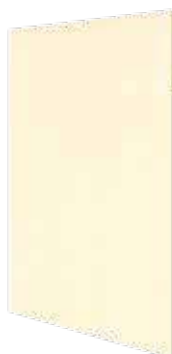

CREMA 22 mm



RÚSTICO
NATURAL 22 mm



RÚSTICO
TABACO 22 mm



RÚSTICO
BLANCO 22 mm



DUNA 22 mm

CONTRACARAS BACK SIDE CONTREBALLESSEMT

EJEMPLO CONTRACARAS LACADAS | EX. LAQUERED BACK SIDE | EX. CONTREBALANCEMENT LAQUE



NIGÚ SEDA



CEREZO OSCURO



WENGUÉ DISEÑO



GRIS OSCURO SEDA

Otros consultar.
Other consulting.
Autre conseil.

COMPLEMENTOS COMPLEMENTS COMPLÉMENTAIRES

CORNISA CLÁSICA

CLASSIC CORNICE | CLASSIQUE CORNICHE



b 365 **Cod.** 343001

PORTALUZ CLÁSICO

ANTIQUE CORNICE | CORNICHE ÉPOQUÉ



b 365 **Cod.** 346001

CORNILUZ

FILLERS / CORNISE-PELMET | FILEUR / CACHE-LUMIERE



b 365 **Cod.** 340001

ZÓCALO

PLINTH | SOCLE

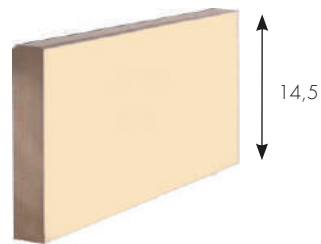

b 244 **Cod.** 349001

TERMINAL ALTO / SOBRE ENCIMERA

TALL TERMINAL / OVER THE WORKTOP | TERMINAL HAUT / SUR PLAN DE TRAVAIL



			Cod.	
a↑	b→	↙	350001	
70	30	35	70	xx
80	30	35	80	xx
90	30	35	90	xx
130	30	35	130	xx
145	30	35	145	xx

TERMINAL BAJO / S. COLUMNA / COLUMNA

BASE TERMINAL / S.COLUMNS / COLUMN | TERMINAL BAS / 1/2 COLONNE / COLONNE



			Cod.	
a↑	b→	↙	351001	
70	30	60	70	xx
80	30	60	80	xx
90	30	60	90	xx
145	30	60	145	xx
215	30	60	215	xx
235	30	60	235	xx

BOTELLERO COLMENA

HIVE BOTTLE HOLDER | CASIER À BOUTEILLES RUCHE



			Cod.					Cod.	
a↑	b→		361001		a↑	b→		361001	
45	30		4530	xx	80	15		8015	xx
45	45		4545	xx	80	30		8030	xx
45	60		4560	xx	80	45		8045	xx
45	90		4590	xx	80	60		8060	xx
70	15		7015	xx	90	15		9015	xx
70	30		7030	xx	90	30		9030	xx
70	45		7045	xx	90	45		9045	xx
70	60		7060	xx	90	60		9060	xx

DECORATIVO / BANDEJERO

DECORATIVE / TRAY UNITS | NICHES OUVERTES COLORIS FACADE HORIZONTALES ET VERTICALES



			Cod.					Cod.	
BANDEJERO DECORATIVO			360001		BANDEJERO DECORATIVO			360001	
a↑	b→	↙	370001		a↑	b→	↙	370001	
45	30	35	4530	xx	45	30	60	453060	xx
45	45	35	4545	xx	45	45	60	454560	xx
45	60	35	4560	xx	45	60	60	456060	xx
45	90	35	4590	xx	45	90	60	459060	xx
70	15	35	7015	xx	70	15	60	701560	xx
70	30	35	7030	xx	70	30	60	703060	xx
70	45	35	7045	xx	70	45	60	704560	xx
70	60	35	7060	xx	70	60	60	706060	xx
80	15	35	8015	xx	80	15	60	801560	xx
80	30	35	8030	xx	80	30	60	803060	xx
80	45	35	8045	xx	80	45	60	804560	xx
80	60	35	8060	xx	80	60	60	806060	xx
90	15	35	9015	xx	90	15	60	901560	xx
90	30	35	9030	xx	90	30	60	903060	xx
90	45	35	9045	xx	90	45	60	904560	xx
90	60	35	9060	xx	90	60	60	906060	xx

Las imágenes representan el modelo, pero no el acabado.
The images represent the model, but not the finish.
Les images représentent le modèle, mais pas la finition.



BC3
COCINAS



Polilaminado
Polilamine
Polymère

opciones
a tu estilo

Modelo Madrid
Folio 73 Azul Nova / Folio 70 Gris Claro
Folio 76 Nogal Rinaldi

BC3
COCINAS

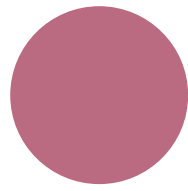

Lacado
Lacquered
Laque



XÁTIVA AZUL OXFORD MATE



LACADO LACQUERED LAQUE

C4



Lacado: Normalmente sobre DM. El proceso de lacado, consiste en aplicar una imprimación sobre la puerta, proceder al lijado y terminar con la aplicación de la laca. La belleza de la laca es la calidad que ofrece su acabado, el tacto de una cocina de mueble lacado es inigualable. Puede elegir entre numerosos colores, acabados y tipos de puertas lacadas, desde brillos, mates, texturados o envejecidos con gamas de diseños de puertas modernas o clásicas.

Lacquered: Usually on DM, The painting process is to apply a primer on the door, proceed to sanding and finish with the application of lacquer.

The beauty on lacquer allows o obtain a smooth surface.

The feel of a kitchen with lacquered doors is unique, with possibility of choice between many colours, finishes (gloss, matte, textured, picking, aging,...) and different types of doors (modern, classical,...)

Laque: Nos laques sont appliquées sur des panneaux MDF (Panneaux de fibres de moyenne densité). Plusieurs couches sont nécessaires pour obtenir un rendu parfait. Nous réalisons des laques mates, satinées et brillantes au prix de base, sur nos 70 coloris standards.

Nous pouvons également réaliser des coloris du RAL avec supplément.

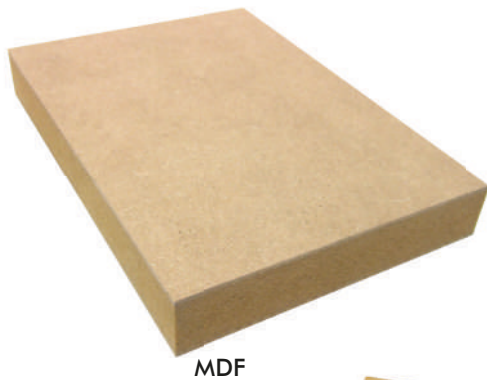

MDF



PUERTAS LACA
LACQUERED DOORS / PORTES EN LAQUE

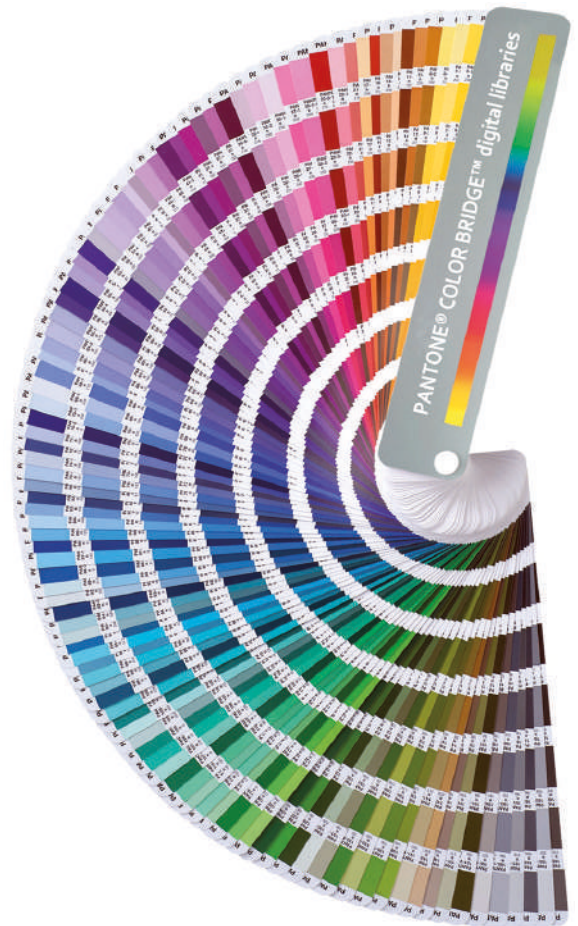

ACABADOS / FINISHES / FINITIONS



GAMA ONE



ONE LISA
BLANCO

Cod	LAC562
↑ ↓	19MM



ONE 2V
BLANCO ROTO

Cod	LAC564
↑ ↓	19MM

COLORES | COLOURS | COLORIS

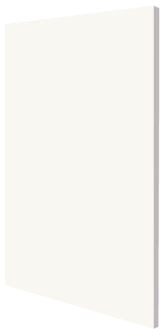

BLANCO



GRAFITO



NEGRO



NUBE



NIGÚ



PERGAMÓN ONE



BLANCO ROTO



TERRA



BEIG GRISÁCEO

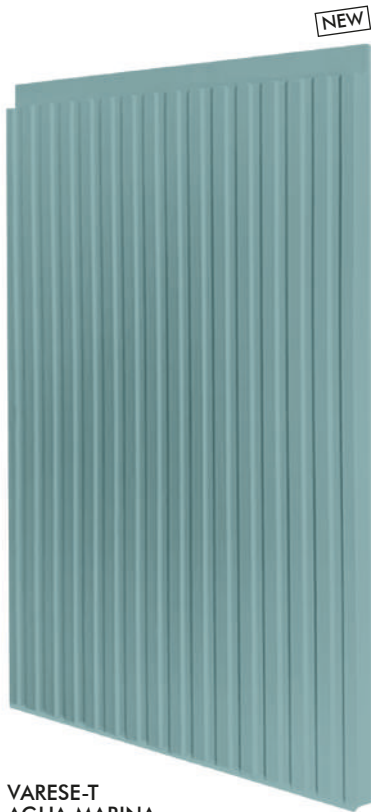

VARESE-T
AGUA MARINA

Cod	LAC809T
↓	22MM

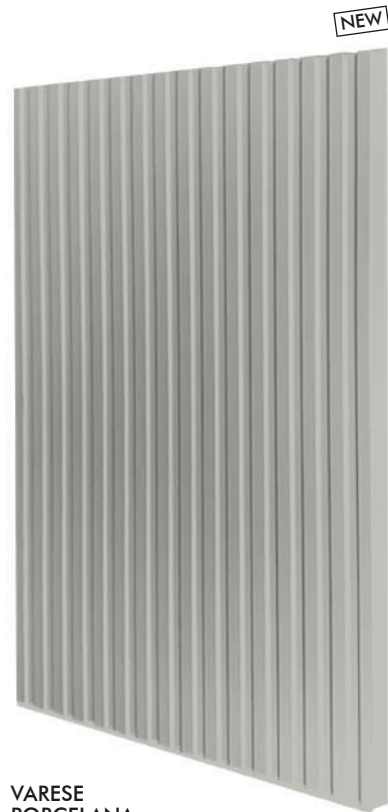

VARESE
PORCELANA

Cod	LAC809
↓	22MM

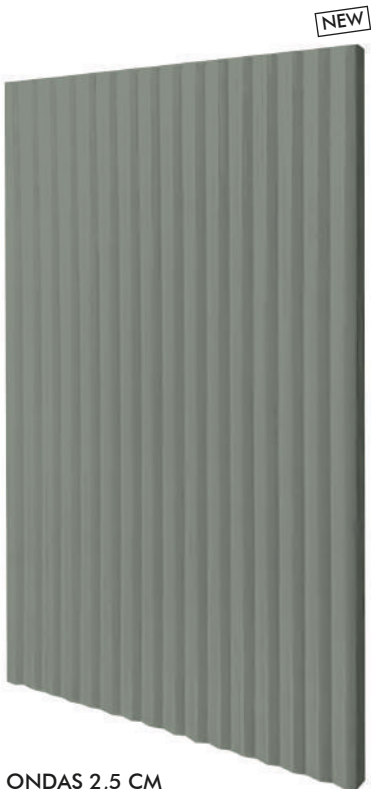

ONDAS 2,5 CM
MENTA

Cod	LAC571
↓	22MM

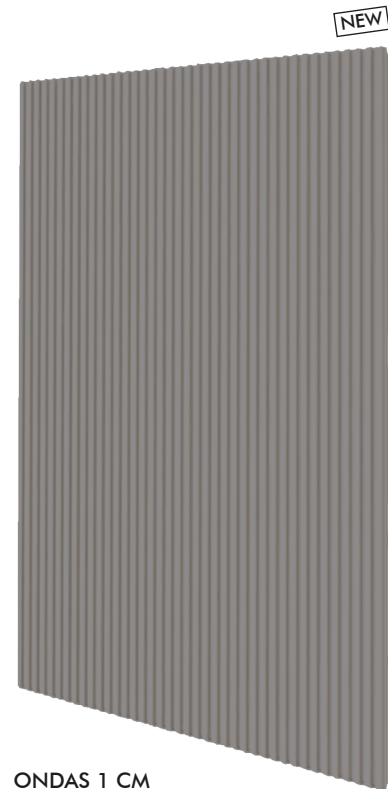

ONDAS 1 CM
GRIS NEUTRO

Cod	LAC572
↓	22MM



YAKARTA
AYURE

Cod	LAC830
↓	22MM



NANTES
LANDALO

Cod	LAC520
↓	22MM





DRESDE
STONE

Cod	LAC127
↓	22MM



CADAQUES
BEIG GRISÁCEO

Cod	LAC085
↓	22MM



ORLEANS C/T
SOMBRA

Cod	LAC568
↓	22MM



OSTENDE
TEXAS

Cod	LAC569
↓	22MM



**DENVER
NIGÜ**

Cod	LAC128
	22MM



**BALTIMORE
ANTRACITA**

Cod	LAC049
	22MM



**MILOS
DESIERTO**

Cod	LAC496
	22MM

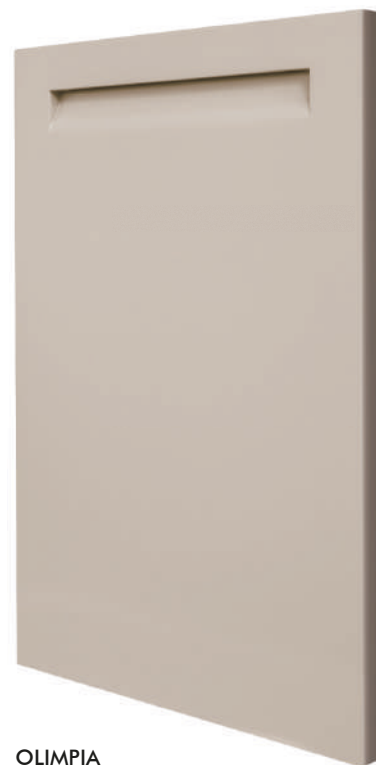

**OLIMPIA
COCO**

Cod	LAC570
	22MM



NUEVO LIMA
NUBE

Cod	LAC446
↓	22MM



CAMBRIDGE
GRIS PERLA

Cod	LAC567
↓	22MM



LIEJA
BLANCO

Cod	LAC447
↓	22MM



**MANACOR
VULCANO SEDA**

Cod	LAC485
	19MM



**XÁTIVA
COCO**

Cod	LAC841
	22MM



**SEGURA
NIGÚ SEDA**

Cod	LAC684
	22MM



**MAELLA T2 8 cm
BLANCO ROTO SEDA**

Cod	LAC483
	19MM



GRÉCIA
NIGÜ SEDA

Cod	LAC246
↓	22MM



DOHA
BEIG GRISÁCEO SEDA

Cod	LAC126
↓	22MM

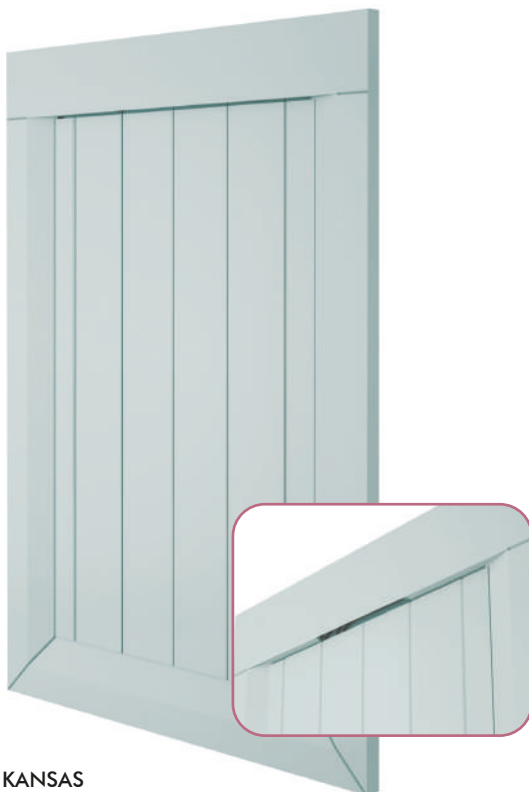

KANSAS
GRIS PERLA SEDA

Cod	LAC290
↓	22MM

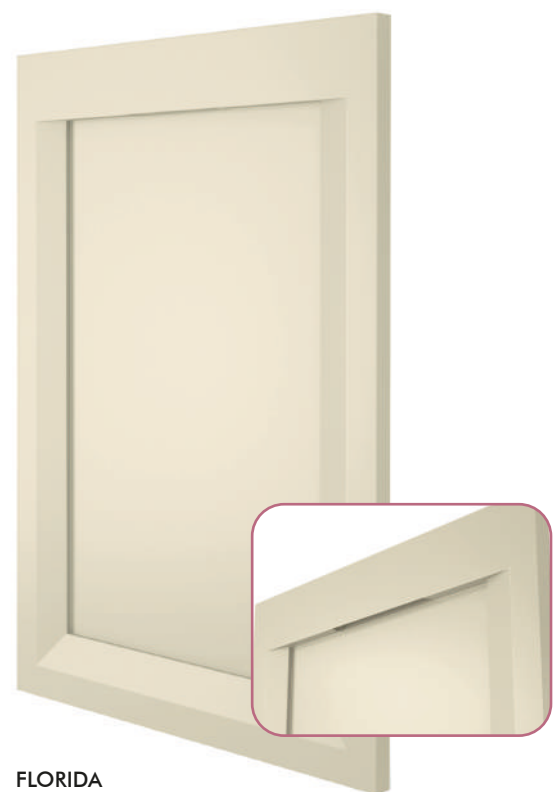

FLORIDA
BEIG SEDA

Cod	LAC204
↓	22MM



MÓNACO
BLANCO BRILLO

Cod	LAC491
↓	22MM



PARÍS
HUESO PATINADO

Cod	LAC607
↓	22MM



SILOS
BLANCO SEDA

Cod	LAC692
↓	22MM

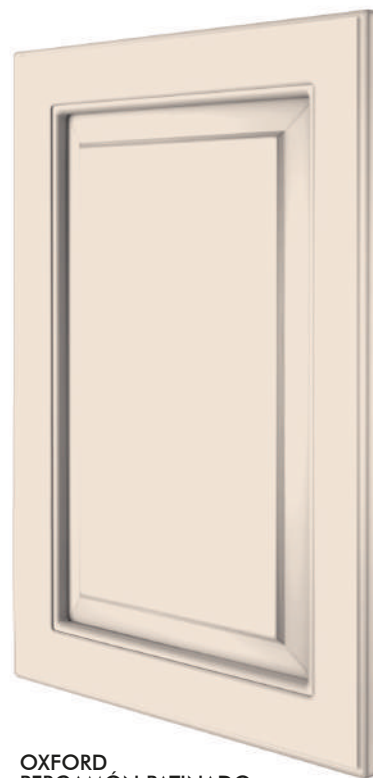

OXFORD
PERGAMÓN PATINADO

Cod	LAC566
↓	22MM



FLORENCIA
PERGAMÓN PATINADO

Cod	LAC203
↓	22MM



CÁUCASO
BLANCO FILOS ORO

Cod	LAC082
↓	22MM





CORINTIA
SILICE SEDA

Cod	LAC083
	22MM

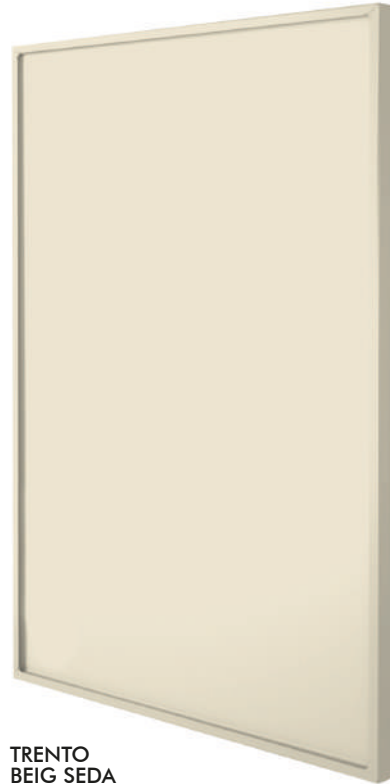

TRENTO
BEIG SEDA

Cod	LAC727
	22MM



ANETO
VULCANO SEDA

Cod	LAC008
	22MM



EVEREST
TIRADOR NOGAL

Cod	LAC165
	22MM

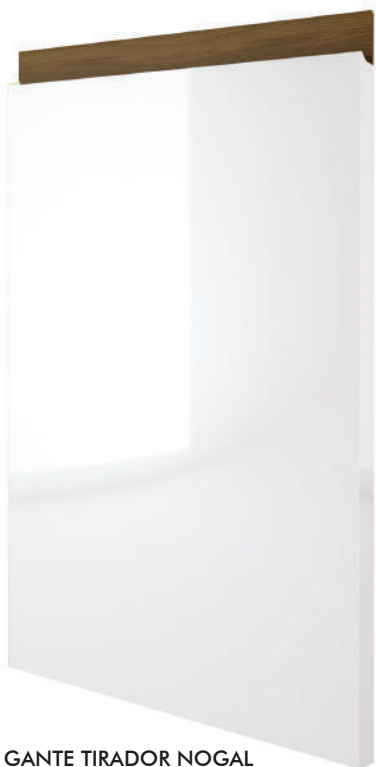

GANTE TIRADOR NOGAL
BLANCO

Cod	LAC245
↓	22MM

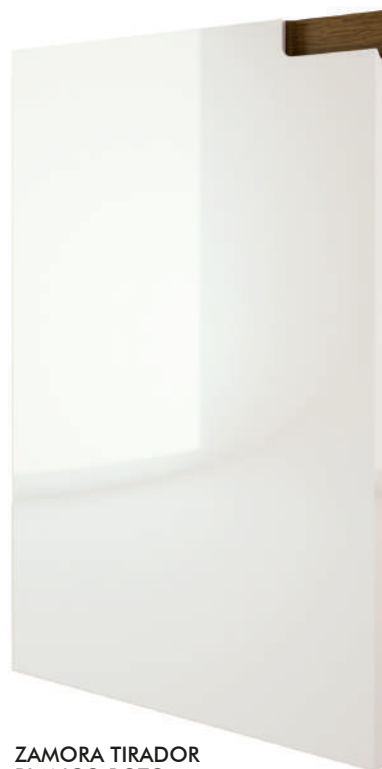

ZAMORA TIRADOR
BLANCO ROTO

Cod	LAC921
↓	22MM



ELENA TIRADOR NOGAL
BLANCO

Cod	LAC164
↓	22MM

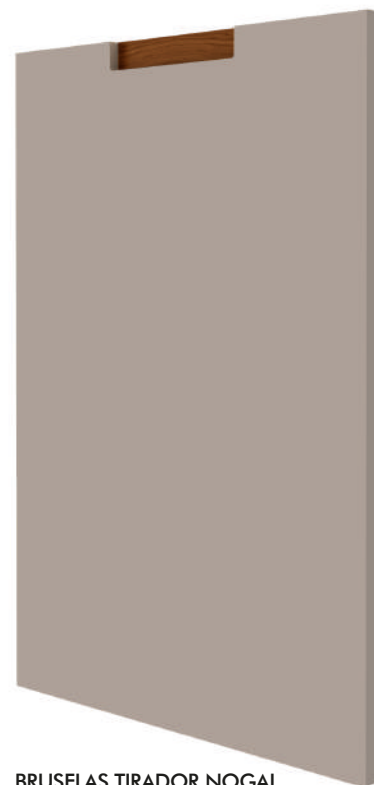

BRUSELAS TIRADOR NOGAL
TERRA

Cod	LAC045
↓	22MM



**PALENCIA
BLANCO**

Cod	LAC604
	22MM



**PALMA
BLANCO**

Cod	LAC606
	22MM



**CRONOS
NUBE**

Cod	LAC084
	22MM



**APOLO FILO CROMO
BLANCO**

Cod	LAC007
	22MM

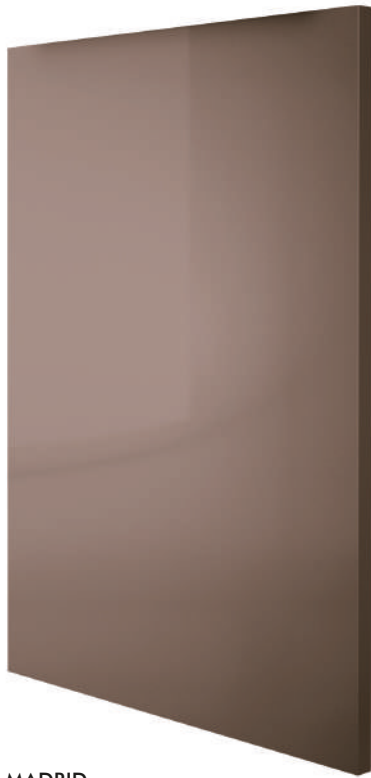

MADRID
TERROSA

Cod	LAC481
↓	22MM



BOMBAY
BLANCO

Cod	LAC047
↓	22MM





**WISEU
BLANCO**

Cod	LAC808
	22MM

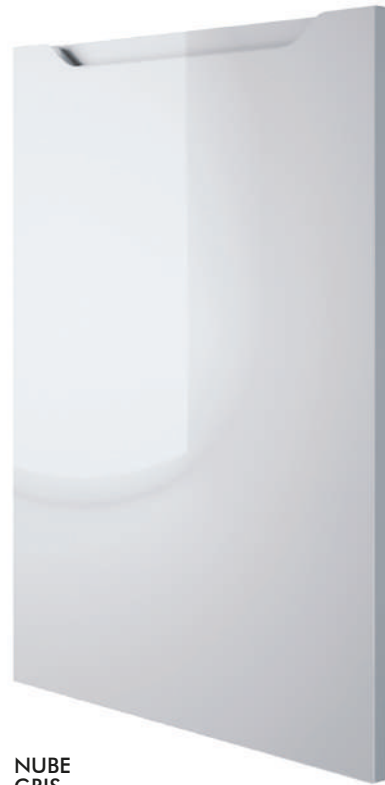

**NUBE
GRIS**

Cod	LAC524
	22MM



**MÁLAGA
BLANCO SEDA**

Cod	LAC484
	22MM



**VEGA
MAPACHE**

Cod	LAC807
	22MM

COLORES COLOURS COULEURS

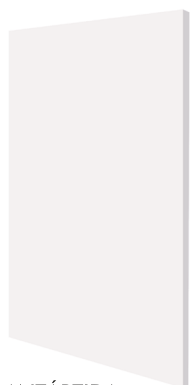

ANTÁRTIDA

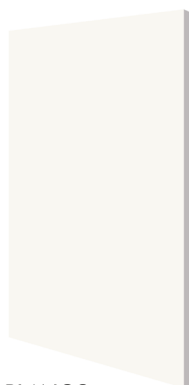

BLANCO



BLANCO ROTO

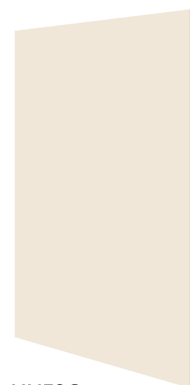

HUESO

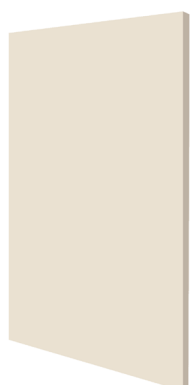

MAGNOLIA



BEIG



PERGAMÓN

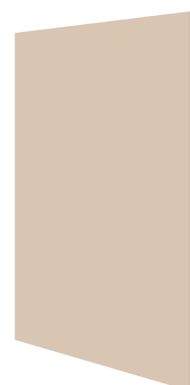

MARFIL

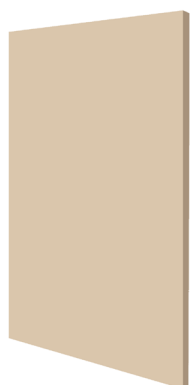

DESIERTO



TEXAS



NIGÚ



TERRACOTA

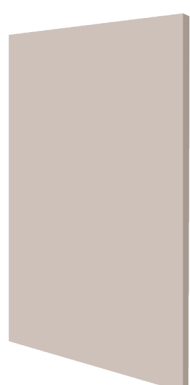

COCO



TERRA



TOFFE

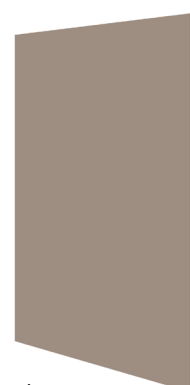

LÁNDALO



VULCANO



MARTE



TERROSA



CORZO

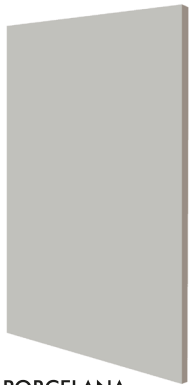

PORCELANA

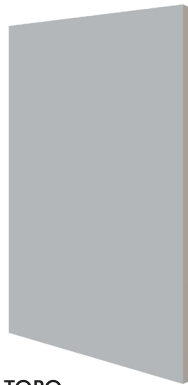

TOPO



AYURE



BEIG GRISÁCEO

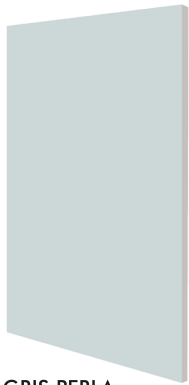

GRIS PERLA



GRIS



LUNA

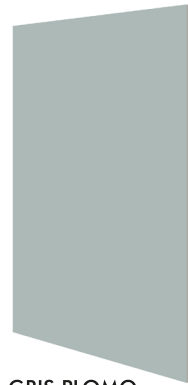

GRIS PLOMO



SOMBRA



NUBE



OTOÑO



GRIS NEUTRO

COLORES COLOURS COULEURS



STONE



CENIZA



MAPACHE



MARENGO

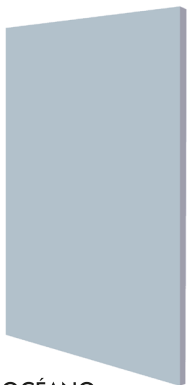

OCÉANO

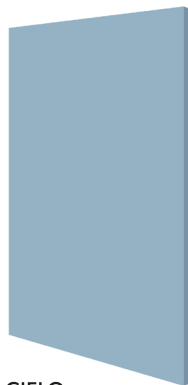

CIELO



MEDITERRÁNEO



EGEO

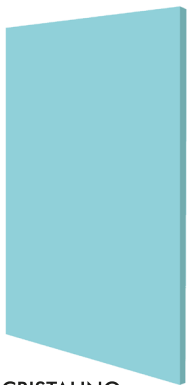

CRISTALINO



LAGO



TURQUESA



AZUL REAL

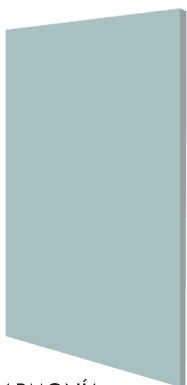

ARMONÍA

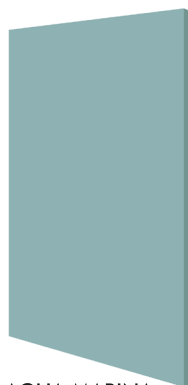

AGUA MARINA



PRIMAVERA



VERDE AZULADO

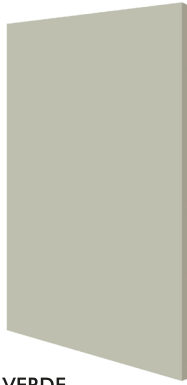

VERDE CLARO

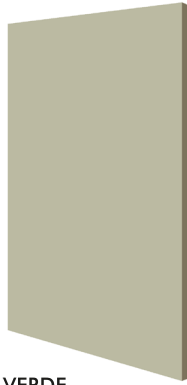

VERDE FONTANA



GREEN



BOSQUE

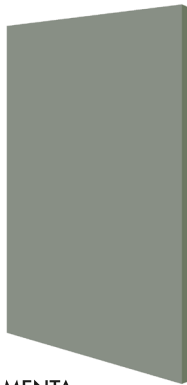

MENTA



TRÉBOL



MUSGO



ALGA

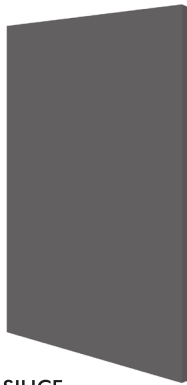

SILICE

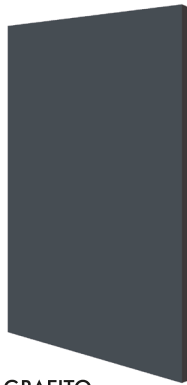

GRAFITO



ANTRACITA



NEGRO

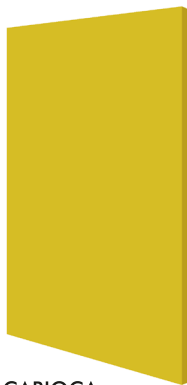

CARIOCA



CEREZA



RIOJA



AZUL OXFORD

Nota: nuevos colores consultar / Note: new colors consult / Remarque: nouvelles couleurs consulter

COLORES COLOURS COULEURS

COMPLEMENTOS COMPLEMENTS COMPLEMENTS

CORNISA CLÁSICA

CLASSIC CORNICE | CLASSIQUE CORNICHE



\overline{b} Cod.
365 443001

CORNISA ÉPOCA

ANTIQUE CORNICE | CORNICHE ÉPOQUÉ



\overline{b} Cod.
365 444001

PORTALUZ CLÁSICO

CLASSIC PELMET | CACHE-LUMIÈRE CLASSIQUE



\overline{b} Cod.
365 446001

PORTALUZ ÉPOCA

ANTIQUE PELMET | CACHE-LUMIÈRE ÉPOQUE



\overline{b} Cod.
365 447001

CORNILUZ

FILLERS / CORNISE-PELMET | FILEUR / CACHE-LUMIÈRE



\overline{b} Cod.
365 440001

ZÓCALO

PLINTH | SOCLE

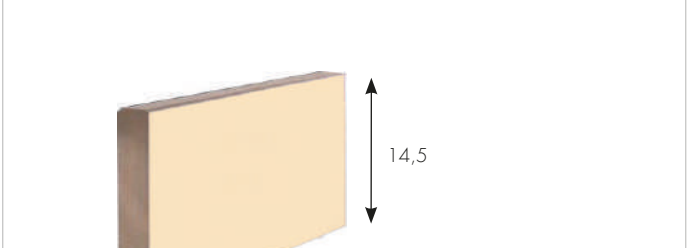

\overline{b} Cod.
360 449001

TERMINAL ALTO / SOBRE ENCIMERA

TALL TERMINAL / WORKTOP | TERMINAL HAUT / SUR PLAN DE TRAVAIL

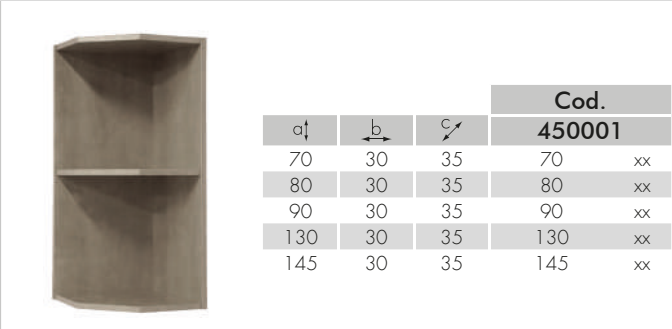

			Cod.
a_t	\overline{b}	φ	450001
70	30	35	70 xx
80	30	35	80 xx
90	30	35	90 xx
130	30	35	130 xx
145	30	35	145 xx

TERMINAL BAJO / S. COLUMNA / COLUMNA

BASE TERMINAL / S. COLUMNS / COLUMN | TERMINAL BAS / 1/2 COLONNE / COLONNE

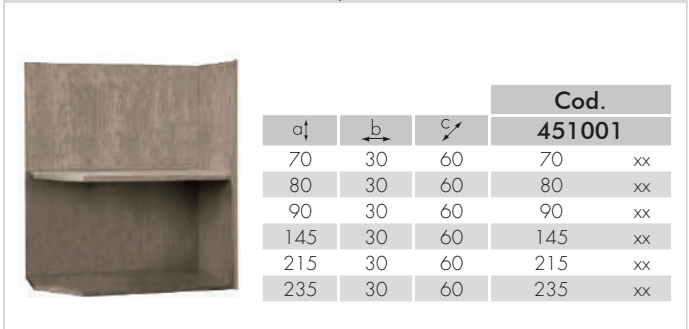

			Cod.
a_t	\overline{b}	φ	451001
70	30	60	70 xx
80	30	60	80 xx
90	30	60	90 xx
145	30	60	145 xx
215	30	60	215 xx
235	30	60	235 xx

COMPLEMENTOS COMPLEMENTS COMPLEMENTS

COMPLEMENTOS COMPLEMENTS COMPLEMENTS

DECORATIVO / BANDEJERO

DECORATIVE / TRAY UNITS | NICHES OUVERTES COLORIS FACADE



BANDEJERO DECORATIVO			Cod. 460001	BANDEJERO DECORATIVO			Cod. 460001
BANDEJERO DECORATIVO			470001	BANDEJERO DECORATIVO			470001
a†	b	c↗		a†	b	c↗	
45	30	35	4530 xx	45	30	60	453060 xx
45	45	35	4545 xx	45	45	60	454560 xx
45	60	35	4560 xx	45	60	60	456060 xx
45	90	35	4590 xx	45	90	60	459060 xx
70	15	35	7015 xx	70	15	60	701560 xx
70	30	35	7030 xx	70	30	60	703060 xx
70	45	35	7045 xx	70	45	60	704560 xx
70	60	35	7060 xx	70	60	60	706060 xx
80	15	35	8015 xx	80	15	60	801560 xx
80	30	35	8030 xx	80	30	60	803060 xx
80	45	35	8045 xx	80	45	60	804560 xx
80	60	35	8060 xx	80	60	60	806060 xx
90	15	35	9015 xx	90	15	60	901560 xx
90	30	35	9030 xx	90	30	60	903060 xx
90	45	35	9045 xx	90	45	60	904560 xx
90	60	35	9060 xx	90	60	60	906060 xx

BOTELLEROS

BOTTLE HOLDER | CASIER À BOUTEILLES

BOTELLERO COLMENA



		Cod. 461001	
a†	b		
45	30	4530	xx
45	45	4545	xx
45	60	4560	xx
45	90	4590	xx
70	15	7015	xx
70	30	7030	xx
70	45	7045	xx
70	60	7060	xx
80	15	8015	xx
80	30	8030	xx
80	45	8045	xx
80	60	8060	xx
90	15	9015	xx
90	30	9030	xx
90	45	9045	xx
90	60	9060	xx

BOTELLERO CON OLAS



		Cod. 462001	
a†	b		
45	30	4530	xx
45	45	4545	xx
45	60	4560	xx
45	90	4590	xx
70	15	7015	xx
70	30	7030	xx
70	45	7045	xx
70	60	7060	xx
80	15	8015	xx
80	30	8030	xx
80	45	8045	xx
80	60	8060	xx
90	15	9015	xx
90	30	9030	xx
90	45	9045	xx
90	60	9060	xx

PLATERO DECORATIVO N°1

DECORATIVE PLATE RACK N°1 | VAISSELIER N°1



			Cod.	
a†	b	c	485001	
70	60	35	7060	xx
70	80	35	7080	xx
70	90	35	7090	xx
90	60	35	9060	xx
90	80	35	9080	xx
90	90	35	9090	xx

PLATERO DECORATIVO N°2

DECORATIVE PLATE RACK N°2 | VAISSELIER N°2



			Cod.	
a†	b	c	485002	
70	60	35	7060	xx
70	80	35	7080	xx
70	90	35	7090	xx
90	60	35	9060	xx
90	80	35	9080	xx
90	90	35	9090	xx

COLUMNA DIAMANTE

DECORATIVE DIAMOND / TURNED COLUM | PILASTRE DIAMANT

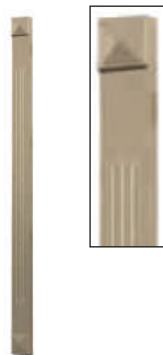

		Cod.	
DIAMANTE		434001	
a†	b		
70	5	70	xx
90	5	90	xx
130	5	130	xx
220	5	220	xx
70	10	7010	xx
90	10	9010	xx
130	10	13010	xx
220	10	22010	xx

COLUMNA TORNEADA EXTRAÍBLE

REMOVABLE TURNED COLUM | PILASTRE TOURNE



			Cod.	
a†	b		436001	
70	15	70	xx	

CAMPANA 1

1 HOOD | HOTTE 1



			Cod.	
a†	b	c	480001	
110	90	50	90	xx

CAMPANA 2

2 HOOD | HOTTE 2



			Cod.	
a†	b	c	480002	
110	90	54	90	xx

CAMPANA 3

3 HOOD | HOTTE 3



			Cod.	
a†	b	c	480003	
110	90	55	90	xx

CAMPANA 4

4 HOOD | HOTTE 4



			Cod.	
a†	b	c	480004	
110	90	50	90	xx

CAMPANA 5

5 HOOD | HOTTE 5



a	b	c	Cod.
110	90	54	480005
			90 xx

CAMPANA 6

6 HOOD | HOTTE 6



a	b	c	Cod.
110	90	55	480006
			90 xx

CAMPANA 7

7 HOOD | HOTTE 7



a	b	c	Cod.
110	90	52	480007
			90 xx

CAMPANA 8

8 HOOD | HOTTE 8



a	b	c	Cod.
90	90	54	480008
			90 xx

CAMPANA 9

9 HOOD | HOTTE 9



a	b	c	Cod.
110	90	50	480009
			90 xx

CAMPANA 12

12 HOOD | HOTTE 12



a	b	c	Cod.
90	90	50	480012
			90 xx

CAMPANA 13

13 HOOD | HOTTE 13



a	b	c	Cod.
110	90	55	480013
			90 xx

CAMPANA 14

14 HOOD | HOTTE 14



a	b	c	Cod.
110	90	55	480014
			90 xx

BOB
COCINAS



Lacado
Lacquered
Laque

el color
de tus sueños



BC3
COCINAS

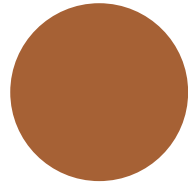

Madera
Wood
Bois



VEGA ROBLE NUDOS H03 Y BLANCO MATE





Madera maciza: Puertas formadas por listones de madera maciza unidos entre sí y posteriormente tratado con barnices, tintes, etc... La madera maciza permite hacer molduras.

Madera rechapada: Tablero de MDF recubierto por una chapa de madera natural. Presenta cantos de madera maciza con sellado antihumedad y las puertas son planas o enmarcadas. La puerta una vez canteada recibe los tratamientos típicos de la madera (barnices, tintes...).

Solid wood: Doors made of solid wood slats bound together. The solid wood allows to make moldings.

Wood veneered panel: MDF covered with a wood veneer. It features solid wood with edges sealed against moisture. Doors can be smooth, framed, shaped, etc... once edged receive typical treatment for wood (varnish, tint...).

Bois massif: Porte réalisées par assemblage de lames parfaitement collées et traitées au préalable. Le bois massif permet de mouler la façade.

Plaqué bois: Porte réalisée avec un MDF (panneau de fibres de moyenne densité) sur le quel on plaque une feuille de bois. Les chants peuvent être plaqués en massif.



MADERAS | WOODS | BOIS

A = ALDER | ALDER | AULNE
 ABT = ABETO TRICAPA | THREE LAYER FIR | TRI-COUCHES SAPIN
 AK = AKUA | AKUA | AKUA
 CA = CASTAÑO | CHESTNUT | CHÂTAIGNIER
 C = CEREZO | CHERRY | CERISIER
 F = FRESNO | ASH TREE | FRESNE
 FO = FRESNO OLIVATO | ASH TREE OLIVATO | FRESNE OLIVATO
 H = HAYA | BEECH | HÊTRE
 N = NOGAL | WALNUT | NOYER
 P = PINO | PINE TREE | SAPIN
 R = ROBLE | OAK | CHÊNE
 RN = ROBLE NUDOS | OAK KNOTS | CHENE A NOEUDS
 RP = ROBLE PREFABRICADO | PREFABRICATED OAK | PRÉFABRIQUÉS CHÊNE
 PT = PINO TEA | PINE TEA | SAPIN TEA
 W = WENGUE | WENGUE | WENGUE

BARNICES | VARNISHES | VERNIS

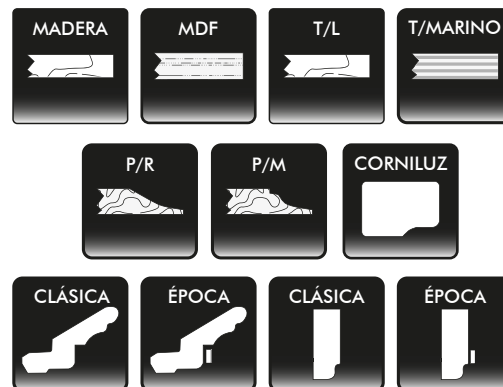



HANNOVER

Cod MAD301



CADAQUÉS

Cod MAD080



CHICAGO T/L

Cod MAD097



MANILA T/L

Cod MAD495



ALBOX-MONTREAL T/L

Cod MAD010



VARESE

Cod MAD732



ONDA

Cod MAD569



TREVISO T/L

Cod MAD73A



ESTAMBUL

Cod MAD163



TORINO 24 T/L

Cod MAD732



ALBOX T/L

Cod MAD009



CASTELLÓN

Cod MAD08A



CASTELLÓN C/ TIRADOR

Cod MAD08A



CHESTE T/L

Cod MAD08B



HUELVA T/L

Cod MAD261



ALDAYA

Cod MAD009



GÉNOVA

Cod MAD248



BURDEOS M/8

Cod MAD044



ORLANDO

Cod MAD568



VIGO

Cod MAD806



MARBELLA T/L

Cod MAD494



DAKAR T/L

Cod MAD123



OVIEDO T/L

Cod MAD567



TUDELA T/L

Cod MAD731



322



ANR



GINEBRA T/L

Cod MAD244



321

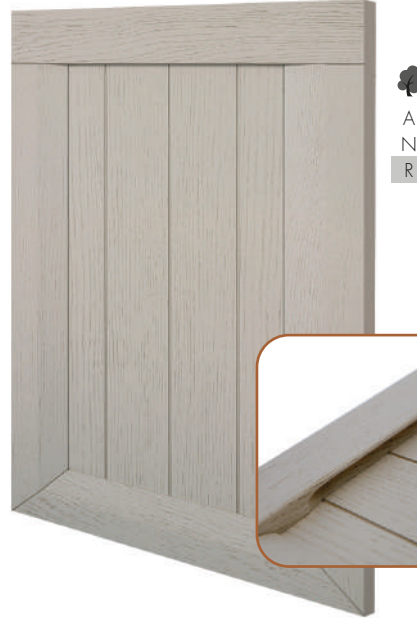

ANR



BERNA T/L

Cod MAD049



352



AR



LINARES T/L

Cod MAD444



349



CAR



ARANJUEZ T/L

Cod MAD008



BOSTON

Cod MAD047



BADAJOZ

Cod MAD040



ÉVORA

Cod MAD162

BARNICES VARNISHES VERNIS



100
NATURAL



102
NOGAL



104
BETULA



106
ENTONADO



202
AVELLANA



203
NOGALINA



204
BETÚN



206
WENGUÉ



208
DORE



211
NOGAL CLARO



212
WENGUÉ OSCURO



103
CEREZO



110
CEREZO CLÁSICO



111
CEREZO ITALIANO



107
MEZQUITA



108
NOGAL OSCURO

BARNICES VARNISHES VERNIS



360
DECAPÉ MARRÓN



301
PÁTINA



302
PÁTINA



305
PÁTINA



306
BLANCO ROTO



320
PÁTINA



321
PÁTINA



322
PÁTINA



325
PÁTINA



349
BEIG



350
BLANCO



351
CREMA



352
VERDE PASTEL



353
GRIS



354
VERDE LUZ



355
VERDE MAR



R

356
MARRÓN



R

357
PIZARRA



R

359
NEGRO



R

361
CELESTE



AK

230
AKUA



R

231
LEÑO



R

254
LEÑO



FO

400

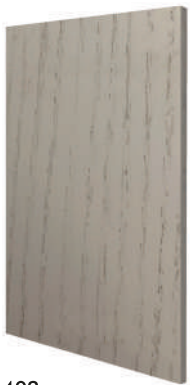

FO

402



FO

403



FO

404



FO

405

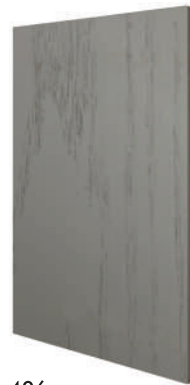

FO

406

Los barnices aquí representados están aplicados sobre diferentes tipos de maderas indicados en las muestras, pudiéndose aplicar sobre otras maderas (Roble, Haya, Cerezo, Maple...), variando así el acabado final. Consultar otras maderas aquí no indicadas.

The varnishes are represented here applied to different types of wood indicated on signs, being able to apply to other woods (Oak, Beech, Cherry, Maple...), thus varying the finish. Consult other woods here not listed.

Les vernis représentés sont appliqués sur des essences de bois bien définies et spécifiées. Il est néanmoins possible de les appliquer sur toutes les essences de bois. Le rendu final sera alors différent du rendu affiché sur le catalogue.

Consultez-nous pour des essences de bois non indiquées au catalogue.



COMPLEMENTOS COMPLEMENTS COMPLEMENTS

CORNISA CLÁSICA

CLASSIC CORNICE | CORNICHE CLASSIQUE



Cerezo, Haya, Roble
Cherry, Beech, Oak
Cerisier, Hêtre, Chêne

\overleftarrow{b}
365

Cod.
543001

CORNISA ÉPOCA

ANTIQUÉ CORNICE | CORNICHE ÉPOQUÉ

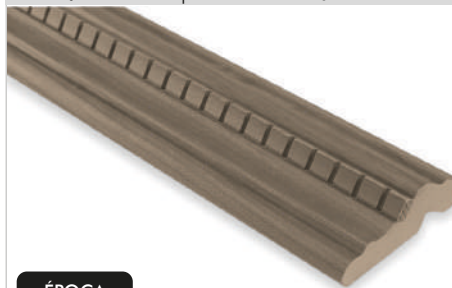

Cerezo, Haya, Roble
Cherry, Beech, Oak
Cerisier, Hêtre, Chêne

\overleftarrow{b}
365

Cod.
544001

PORTALUZ CLÁSICO

CLASSIC PELMET | CACHE-LUMIERE



Cerezo, Haya, Roble
Cherry, Beech, Oak
Cerisier, Hêtre, Chêne

\overleftarrow{b}
365

Cod.
546001

PORTALUZ ÉPOCA

ANTIQUÉ PELMET | CACHE LUMIERE ÉPOQUE



Cerezo, Haya, Roble
Cherry, Beech, Oak
Cerisier, Hêtre, Chêne

\overleftarrow{b}
365

Cod.
547001

CORNILUZ

FILLERS / CORNISE-PELMET | FILEUR / CACHE-LUMIERE



Cerezo, Haya, Roble
Cherry, Beech, Oak
Cerisier, Hêtre, Chêne

\overleftarrow{b}
365

Cod.
540001

ZÓCALO

PLINTH | SOCLE

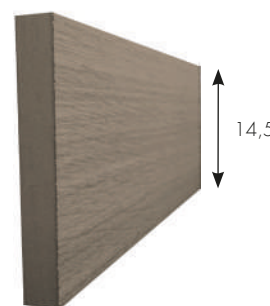

Cerezo, Haya, Roble
Cherry, Beech, Oak
Cerisier, Hêtre, Chêne

\overleftarrow{b}
360

Cod.
549001

TERMINAL ALTO / SOBRE ENCIMERA

TALL TERMINAL / WORKTOP | TERMINAL HAUT / SUR PLAN DE TRAVAIL



Cerezo, Haya, Nogal, Roble
Cherry, Beech, Oak
Cerisier, Hêtre, Chêne

			Cod.	
$a\uparrow$	\overleftarrow{b}	\curvearrowright	550001	
70	30	35	70	xx
80	30	35	80	xx
90	30	35	90	xx
130	30	35	130	xx
145	30	35	145	xx

TERMINAL BAJO / S. COLUMNA / COLUMNA

BASE TERMINAL / S.COLUMNS / COLUMN | TERMINAL BAS / 1/2 COLONNE / COLONNE



Cerezo, Haya, Roble
Cherry, Beech, Oak
Cerisier, Hêtre, Chêne

			Cod.	
$a\uparrow$	\overleftarrow{b}	\curvearrowright	551001	
70	30	60	70	xx
80	30	60	80	xx
90	30	60	90	xx
145	30	60	145	xx
215	30	60	215	xx
235	30	60	235	xx

DECORATIVO / BANDEJERO

DECORATIVE / TRAY UNITS | NICHES OUVERTES PLAQUE BOIS IDEM FACADE



			Cod.					Cod.	
BANDEJERO DECORATIVO			560001		BANDEJERO DECORATIVO			560001	
a†	b	c	570001		a†	b	c	570001	
45	30	35	4530	xx	45	30	60	453060	xx
45	45	35	4545	xx	45	45	60	454560	xx
45	60	35	4560	xx	45	60	60	456060	xx
45	90	35	4590	xx	45	90	60	459060	xx
70	15	35	7015	xx	70	15	60	701560	xx
70	30	35	7030	xx	70	30	60	703060	xx
70	45	35	7045	xx	70	45	60	704560	xx
70	60	35	7060	xx	70	60	60	706060	xx
80	15	35	8015	xx	80	15	60	801560	xx
80	30	35	8030	xx	80	30	60	803060	xx
80	45	35	8045	xx	80	45	60	804560	xx
80	60	35	8060	xx	80	60	60	806060	xx
90	15	35	9015	xx	90	15	60	901560	xx
90	30	35	9030	xx	90	30	60	903060	xx
90	45	35	9045	xx	90	45	60	904560	xx
90	60	35	9060	xx	90	60	60	906060	xx

Cerezo, Haya, Nogal, Roble, Roble Pref, Wengue
Cherry, Beech, Walnut, Oak, Pref Oak, Wenge
Cerisier, Hêtre, Noyer, Chêne, Chêne Pref, Wenge

BOTELLEROS

BOTTLE HOLDER | CASIER À BOUTEILLES

BOTELLERO COLMENA



		Cod.	
a†	b	561001	
45	30	4530	xx
45	45	4545	xx
45	60	4560	xx
45	90	4590	xx
70	15	7015	xx
70	30	7030	xx
70	45	7045	xx
70	60	7060	xx
80	15	8015	xx
80	30	8030	xx
80	45	8045	xx
80	60	8060	xx
90	15	9015	xx
90	30	9030	xx
90	45	9045	xx
90	60	9060	xx

Cerezo, Haya, Nogal, Roble, Roble Pref, Wengue
Cherry, Beech, Walnut, Oak, Pref Oak, Wenge
Cerisier, Hêtre, Noyer, Chêne, Chêne Pref, Wenge

BOTELLERO CON OLAS



		Cod.	
a†	b	562001	
45	30	4530	xx
45	45	4545	xx
45	60	4560	xx
45	90	4590	xx
70	15	7015	xx
70	30	7030	xx
70	45	7045	xx
70	60	7060	xx
80	15	8015	xx
80	30	8030	xx
80	45	8045	xx
80	60	8060	xx
90	15	9015	xx
90	30	9030	xx
90	45	9045	xx
90	60	9060	xx

PLATERO DECORATIVO Nº1

DECORATIVE PLATE RACK Nº1 | VAISSELIER Nº1



Haya, Roble
Beech, Oak
Hêtre, Chêne

		Cod.	
a†	b→	585001	
70	60	7060	xx
70	80	7080	xx
70	90	7090	xx
90	60	9060	xx
90	80	9080	xx
90	90	9090	xx

PLATERO DECORATIVO Nº2

DECORATIVE PLATE RACK Nº2 | VAISSELIER Nº2



Haya, Roble
Beech, Oak
Hêtre, Chêne

		Cod.	
a†	b→	585002	
70	60	7060	xx
70	80	7080	xx
70	90	7090	xx
90	60	9060	xx
90	80	9080	xx
90	90	9090	xx

COLUMNA DIAMANTE

DECORATIVE DIAMOND COLUMN | PILASTRE DIAMANT



Cerezo, Haya, Roble
Cherry, Beech, Oak
Cerisier, Hêtre, Chêne

		Cod.	
Diamante		534001	
a†	b→		
70	5	70	xx
90	5	90	xx
130	5	130	xx
220	5	220	xx
70	10	7010	xx
90	10	9010	xx
130	10	13010	xx
220	10	22010	xx

COLUMNA TORNEADA EXTRAÍBLE

REMOVABLE TURNED COLUMN | PILASTRE TORNE



Cerezo, Haya, Roble
Cherry, Beech, Oak
Cerisier, Hêtre, Chêne

		Cod.	
a†	b→	536001	
70	15	70	xx

CAMPANA 1

1 HOOD | HOTTE 1



Cerezo, Haya, Roble
Cherry, Beech, Oak
Cerisier, Hêtre, Chêne

		Cod	
a†	b→	580001	
110	90	90	xx

CAMPANA 2

2 HOOD | HOTTE 2



Cerezo, Haya, Roble
Cherry, Beech, Oak
Cerisier, Hêtre, Chêne

		Cod	
a†	b→	580002	
110	90	90	xx

CAMPANA 3

3 HOOD | HOTTE 3



Cerezo, Haya, Roble
Cherry, Beech, Oak
Cerisier, Hêtre, Chêne

		Cod	
a†	b→	580003	
110	90	90	xx

CAMPANA 4

4 HOOD | HOTTE 4



Cerezo, Haya, Roble
Cherry, Beech, Oak
Cerisier, Hêtre, Chêne

		Cod	
a†	b→	580004	
110	90	90	xx

CAMPANA 5

5 HOOD | HOTTE 5



Cerezo, Haya, Roble
Cherry, Beech, Oak
Cerisier, Hêtre, Chêne

a†	b	c/	Cod.	
110	90	54	90	xx
580005				

CAMPANA 6

6 HOOD | HOTTE 6



Cerezo, Roble
Cherry, Oak
Cerisier, Chêne

a†	b	c/	Cod.	
110	90	55	90	xx
580006				

CAMPANA 7

7 HOOD | HOTTE 7



Cerezo, Roble
Cherry, Oak
Cerisier, Chêne

a†	b	c/	Cod.	
110	90	52	90	xx
580007				

CAMPANA 8

8 HOOD | HOTTE 8



Cerezo, Haya, Roble
Cherry, Beech, Oak
Cerisier, Hêtre, Chêne

a†	b	c/	Cod.	
90	90	54	90	xx
580008				

CAMPANA 9

9 HOOD | HOTTE 9

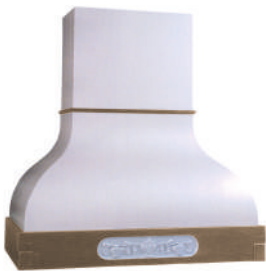

Cerezo, Roble
Cherry, Oak
Cerisier, Chêne

a†	b	c/	Cod.	
110	90	50	90	xx
580009				

CAMPANA 12

12 HOOD | HOTTE 12



Cerezo, Haya, Roble
Cherry, Beech, Oak
Cerisier, Hêtre, Chêne

a†	b	c/	Cod.	
90	90	50	90	xx
580012				

CAMPANA 13

13 HOOD | HOTTE 13



Cerezo, Haya, Roble
Cherry, Beech, Oak
Cerisier, Hêtre, Chêne

a†	b	c/	Cod.	
110	90	55	90	xx
580013				

CAMPANA 14

14 HOOD | HOTTE 14



Cerezo, Haya, Roble
Cherry, Beech, Oak
Cerisier, Hêtre, Chêne

a†	b	c/	Cod.	
110	90	55	90	xx
580014				

BC3
COCINAS

Madera
Wood
Bois

la esencia de
lo natural

Modelo Berna
Madera Nogal

BC3
COCINAS

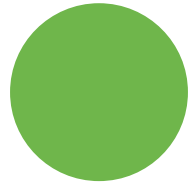

Porcelánico
Porcelain
Porcelaine





LUNAR

Cod PLN12A



KRETA

Cod PLN11B



TRILIUM

Cod PLN20A



CANTO UKA



CANTO IRAZU



CANTO FUJI



FUJI KELYA

Cod PLN11A



FUJI KER 1

Cod PLN111



FUJI KER 2

Cod PLN112



FUJI KER 3

Cod PLN113

BC3
COCINAS

Porcelánico
Porcelain
Porcelaine

reinventando
tu cocina

BC3
COCINAS

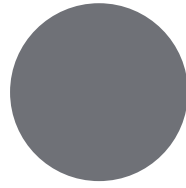

Aluminio / Acero
Aluminum / Steel
Aluminium / Acier

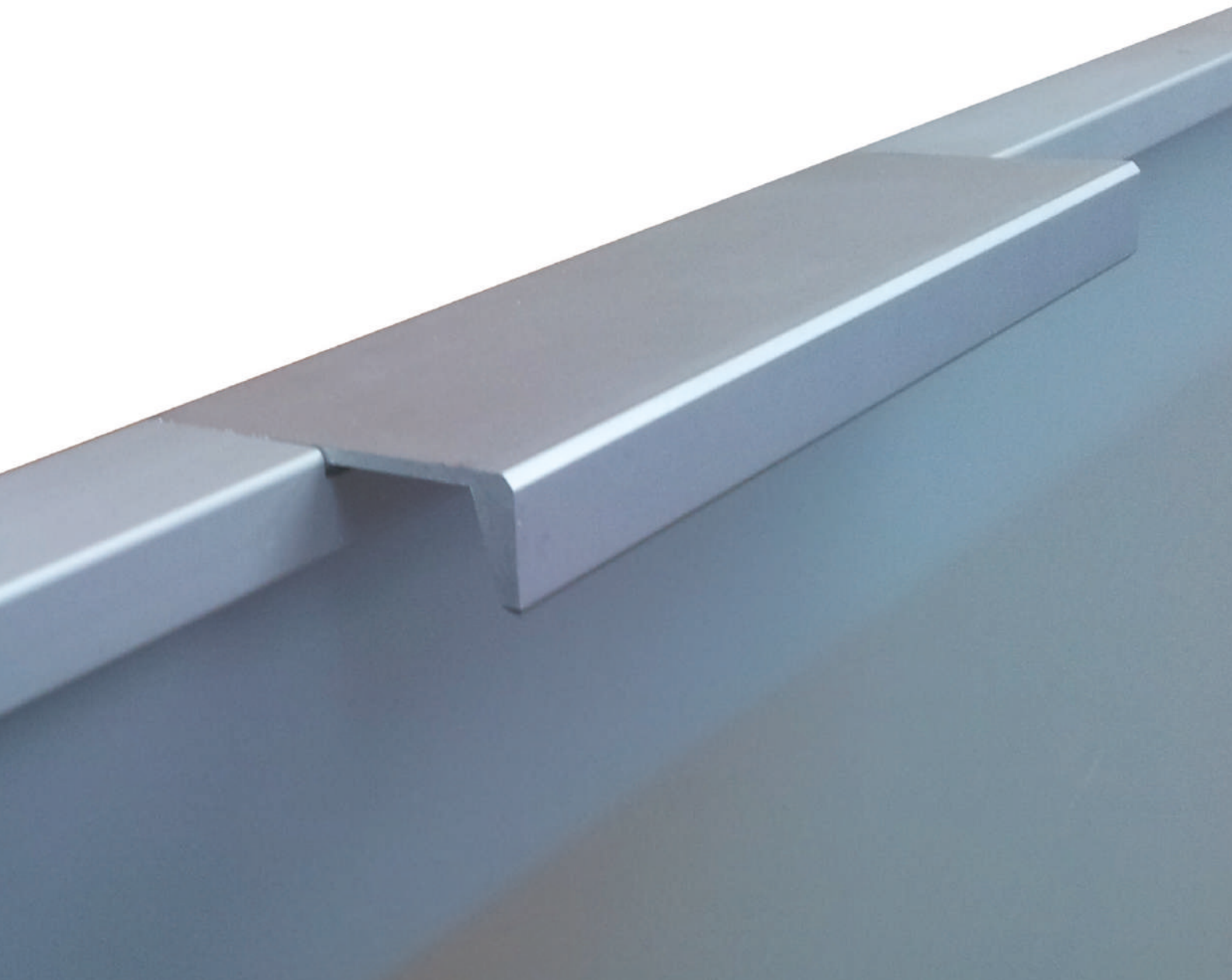

ESTRUCTURAS DE ALUMINIO STRUCTURES OF ALUMINUM STRUCTURES EN ALUMINIUM

Estructuras de aluminio

Sistema modular de perfiles y patas, para componer estructuras bajo muebles y mesas. Precio bajo presupuesto.

Structures of aluminum

Modular system of profiles and legs, to compose structures under furniture and tables. Low budget price.

Structures en aluminium

Système modulaire pour structure de table et de pieds de meubles. Prix sur demande.

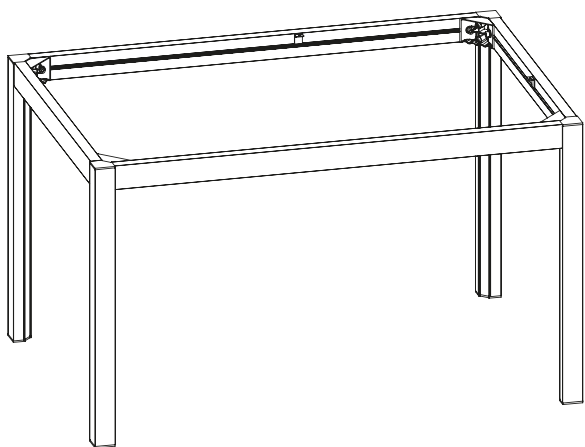

Consultar acabados: Lacado blanco/negro o alto brillo
Ask for other finishes: Black/White or high brightness
Consultez les finitions: Laqué blanc/noir ou haut brillant

ESTRUCTURAS MODULARES MODULAR STRUCTURES STRUCTURES MODULAIRES

Estructuras modulares

Sistema modular para la creación de todo tipo de estanterías. Precio bajo presupuesto.

Modular structures

Modular system for the creation of all types of shelves. Low budget price.

Structures modulaires

Système modulaire pour la création de tous types d'étagères. Prix sur demande.

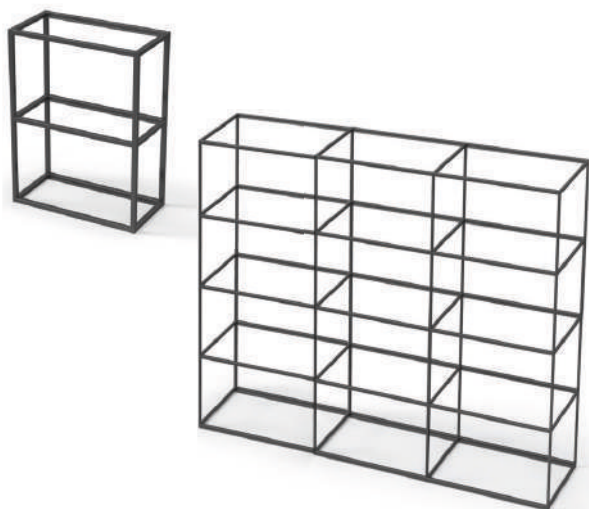

Consultar acabados
Ask for other finishes
Consultez les finitions

VITRINAS DE ALUMINIO SHOWCASE CABINET VITRINES EN ALUMINIUM

Nueva puerta Vitrina P3 AIR con bisagras y tirador integrados en sus perfiles de un diseño recto e innovador, disponible en cromo mate y negro.

New P3 AIR display door with hinges and handle integrated in its profiles in a straight and innovative design, available in matt chrome and black.

Nouvelle porte P3 AIR Showcase avec charnières et poignée intégrées dans ses profilés dans un design droit et innovant, disponible en chrome mat et noir.

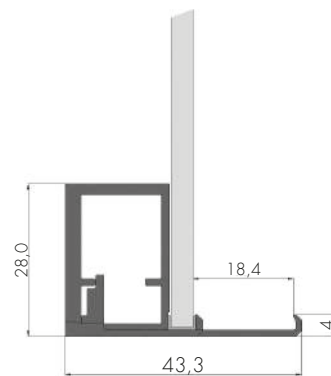
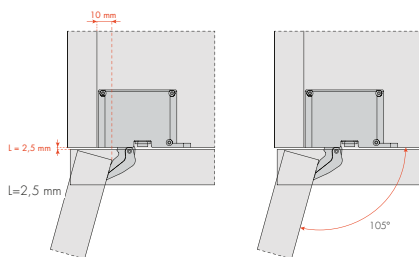

Cod.
721003

VITRINAS DE ALUMINIO SHOWCASE CABINET VITRINES EN ALUMINIUM

VITRINA P4

P4 SHOWCASE | VITRINE P4

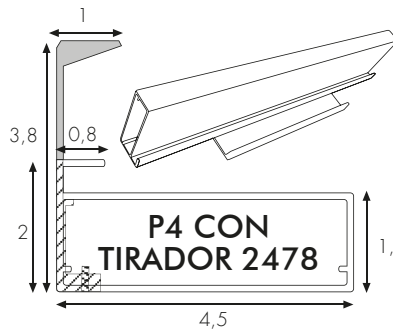
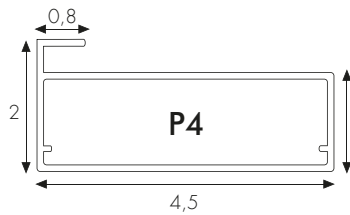

Plata mate
Silver matt
Argent mat
Otros acabados consultar.
Other finishes on request.
Autres finitions sur demande.

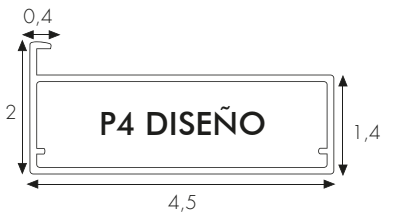

		Cod. 721004								Cod. 721004					
øt	b	P4	P4T	P4D	P4	P4T	P4D	øt	b	P4	P4T	P4D	P4	P4T	P4D
28	60	2860	N	2860	T	2860	D	70	30	7030	N	7030	T	7030	D
28	70	2870	N	2870	T	2870	D	70	35	7035	N	7035	T	7035	D
28	80	2880	N	2880	T	2880	D	70	40	7040	N	7040	T	7040	D
28	90	2890	N	2890	T	2890	D	70	45	7045	N	7045	T	7045	D
28	100	28100	N	28100	T	28100	D	70	50	7050	N	7050	T	7050	D
28	120	28120	N	28120	T	28120	D	70	60	7060	N	7060	T	7060	D
35	60	3560	N	3560	T	3560	D	80	30	8030	N	8030	T	8030	D
35	70	3570	N	3570	T	3570	D	80	35	8035	N	8035	T	8035	D
35	80	3590	N	3590	T	3590	D	80	40	8040	N	8040	T	8040	D
35	90	3580	N	3580	T	3580	D	80	45	8045	N	8045	T	8045	D
35	100	35100	N	35100	T	35100	D	80	50	8050	N	8050	T	8050	D
35	120	35120	N	35120	T	35120	D	80	60	8060	N	8060	T	8060	D
45	60	4560	N	4560	T	4560	D	90	30	9030	N	9030	T	9030	D
45	70	4570	N	4570	T	4570	D	90	35	9035	N	9035	T	9035	D
45	80	4590	N	4590	T	4590	D	90	40	9040	N	9040	T	9040	D
45	90	4580	N	4580	T	4580	D	90	45	9045	N	9045	T	9045	D
45	100	45100	N	45100	T	45100	D	90	50	9050	N	9050	T	9050	D
45	120	45120	N	45120	T	45120	D	90	60	9060	N	9060	T	9060	D
56	60	5660	N	5660	T	5660	D	130	30	13030	N	13030	T	13030	D
56	70	5670	N	5670	T	5670	D	130	35	13035	N	13035	T	13035	D
56	80	5680	N	5680	T	5680	D	130	40	13040	N	13040	T	13040	D
56	90	5690	N	5690	T	5690	D	130	45	13045	N	13045	T	13045	D
56	100	56100	N	56100	T	56100	D	130	50	13050	N	13050	T	13050	D
56	120	56120	N	56120	T	56120	D	130	60	13060	N	13060	T	13060	D

2395 VITRINA ALUMINIO P4

a	b	Cod.
192	216	Aluminio Aluminum Aluminium
		809001

2478 VITRINA ALUMINIO P4 INTEGRADO

a	b	Cod.
126	-	Aluminio Aluminum Aluminium
		809002

ALUMINIO/ACERO ALUMINIUM / STEEL ALUMINIUM / ACIER

VITRINA P6 Y P8

P6 & P8 SHOWCASES | VITRINE P6 ET P8

Nuevas puertas Vitrina P6 con perfiles rectos no ingletados y tirador integrado en todo el largo de la puerta. Con posibilidad de dos colores, cromo mate y negro. Vitrina P8 con posicionamiento de tirador opcional y acabado negro.

New display case P6 with straight non-mitered profiles and integrated handle on the entire length of the door. With possibility of two colors, matt chrome and black. P8 display case with optional handle position and black finish.

Nouvelle porte d'armoire P6 présentant des profils droits sans onglet et une poignée intégrée sur toute la longueur de la porte. Avec possibilité de deux couleurs, chrome mat et noir. Vitrine P8 avec position de poignée en option et finition noire.

P6

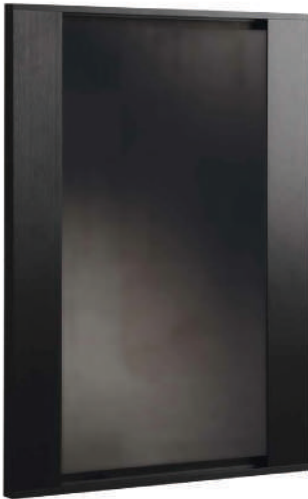

P8



a†	b	Cod.					
		721006			721008		
		P6C	P6N	P8N			
28	60	2860	C	2860	N	2860	N
28	70	2870	C	2870	N	2870	N
28	80	2880	C	2880	N	2880	N
28	90	2890	C	2890	N	2890	N
28	100	28100	C	28100	N	28100	N
28	120	28120	C	28120	N	28120	N
35	60	3560	C	3560	N	3560	N
35	70	3570	C	3570	N	3570	N
35	80	3590	C	3590	N	3590	N
35	90	3580	C	3580	N	3580	N
35	100	35100	C	35100	N	35100	N
35	120	35120	C	35120	N	35120	N
45	60	4560	C	4560	N	4560	N
45	70	4570	C	4570	N	4570	N
45	80	4590	C	4590	N	4590	N
45	90	4580	C	4580	N	4580	N
45	100	45100	C	45100	N	45100	N
45	120	45120	C	45120	N	45120	N
56	60	5660	C	5660	N	5660	N
56	70	5670	C	5670	N	5670	N
56	80	5680	C	5680	N	5680	N
56	90	5690	C	5690	N	5690	N
56	100	56100	C	56100	N	56100	N
56	120	56120	C	56120	N	56120	N

a†	b	Cod.					
		721006			721008		
		P6C	P6N	P8N			
70	30	7030	C	7030	N	7030	N
70	35	7035	C	7035	N	7035	N
70	40	7040	C	7040	N	7040	N
70	45	7045	C	7045	N	7045	N
70	50	7050	C	7050	N	7050	N
70	60	7060	C	7060	N	7060	N
80	30	8030	C	8030	N	8030	N
80	35	8035	C	8035	N	8035	N
80	40	8040	C	8040	N	8040	N
80	45	8045	C	8045	N	8045	N
80	50	8050	C	8050	N	8050	N
80	60	8060	C	8060	N	8060	N
90	30	9030	C	9030	N	9030	N
90	35	9035	C	9035	N	9035	N
90	40	9040	C	9040	N	9040	N
90	45	9045	C	9045	N	9045	N
90	50	9050	C	9050	N	9050	N
90	60	9060	C	9060	N	9060	N
130	30	13030	C	13030	N	13030	N
130	35	13035	C	13035	N	13035	N
130	40	13040	C	13040	N	13040	N
130	45	13045	C	13045	N	13045	N
130	50	13050	C	13050	N	13050	N
130	60	13060	C	13060	N	13060	N

ZÓCALOS PLINTHS SOCLES

ZÓCALO PVC ALUMINIO

PVC ALUMINIUM SKIRTING BOARD | SOCLE PVC ALUMINIUM

Zócalo fabricado en PVC, recubierto de aluminio anodizado. Alta resistencia a humedad y golpes.

Plinth manufactured from PVC, anodized aluminum coated. High resistance to moisture and damage.

Socle fabriqué à partir de PVC, aluminium anodisé revêtu. Haute résistance à l'humidité et les dommages.

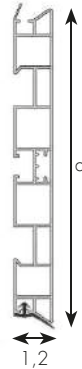

b	a†		Cod.
4 Mts	10	Cromo Mate Matt Chrome Chrome Mat.	749101 10 C
4 Mts	15	Cromo Mate Matt Chrome Chrome Mat.	15 C
4 Mts	17	Cromo Mate Matt Chrome Chrome Mat.	17 C
4 Mts	10	Blanco Mate Matt White Blanc Mat.	10 C
4 Mts	15	Blanco Mate Matt White Blanc Mat.	15 C
4 Mts	10	Negro Mate Matt Black Noir Mat.	10 C
4 Mts	15	Negro Mate Matt Black Noir Mat.	15 C

RINCÓN-ESQUINA FIJO ZÓCALO PVC ALUMINIO ECO

PVC. INSIDE-OUTSIDE CORNER ECO | INTÉRIEUR-EXTÉRIEUR COIN PVC ECO

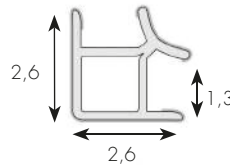

a†		Cod.
10	Cromo Mate Matt Chrome Chrome Mat.	749111 10 C
15	Cromo Mate Matt Chrome Chrome Mat.	15 C
17	Cromo Mate Matt Chrome Chrome Mat.	17 C
10	Blanco Mate Matt White Blanc Mat.	10 C
15	Blanco Mate Matt White Blanc Mat.	15 C
10	Negro Mate Matt Black Noir Mat.	10 C
15	Negro Mate Matt Black Noir Mat.	15 C

RINCÓN-ESQUINA FLEXIBLE ZÓCALO PVC ALUMINIO ECO

PVC. INSIDE-OUTSIDE CORNER ECO | INTÉRIEUR-EXTÉRIEUR COIN PVC ECO

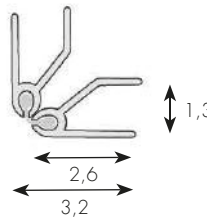

a†		Cod.
10	Cromo Mate Matt Chrome Chrome Mat.	749112 10 C
15	Cromo Mate Matt Chrome Chrome Mat.	15 C
17	Cromo Mate Matt Chrome Chrome Mat.	17 C
10	Blanco Mate Matt White Blanc Mat.	10 C
15	Blanco Mate Matt White Blanc Mat.	15 C
10	Negro Mate Matt Black Noir Mat.	10 C
15	Negro Mate Matt Black Noir Mat.	15 C

PINZA DE ZÓCALO PVC ALUMINIO

PLUS ENCHANCED LEG | CLIP SOCLE PVC ALUMINIUM



Cod.
841006



ALUMINIO/ACERO ALUMINIUM / STEEL ALUMINIUM / ACIER

BC3
COCINAS

Aluminio / Acero
Aluminum / Steel
Aluminium / Acier

elegancia y
robustez

BC3
COCINAS

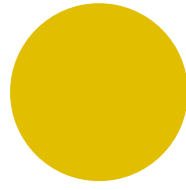

Accesorios / Herrajes
Complements / Hardware
Accessories / Ferrage



ACCESORIOS, HERRAJES, COMPLEMENTOS... ACCESSORIES, HARDWARE, COMPLEMENTS... ACCESSOIRES, QUINCAILLERIE, COMPLÉMENTS...

En este capítulo, dotamos a la cocina de funcionalidad, utilidad y diseño, con elementos de extraordinaria calidad, de las firmas más importantes del mercado internacional. Los tiradores que realzan el estilismo de la cocina, sistemas de cajón con cierre amortiguado y gran almacenaje, múltiples sistemas de apertura para cubrir las necesidades de accesibilidad, 3 gamas diferentes de opciones de almacenamiento de gran robustez, con diferentes terminaciones...

In this chapter, we provide functionality to the kitchen, utility and desing with elements of extraordinary quality of the most important companies in the international market. Handles that enhance the style of the kitchen, drawers systems with high storage and cushioned closing, opening multiple systems to meet the accessibility needs, three different ranges of storage options extremely robust, with different finishes...

Dans ce chapitre, nous équipons les cuisines de fonctionnalité, utilite et le desing avec des éléments de qualité extraordinaire, des entreprises majeur du marché international. Poignées qui améliorent le style de la cuisine, système avec tiroir de fermeture en douceur et de nombreux rangements, overtine de plusieurs systèmes pour repondre à leurs besoins en matière d'accesibilitè 3 gammes differentes avec stochages de grandes robstesse avec terminaisons differentes...

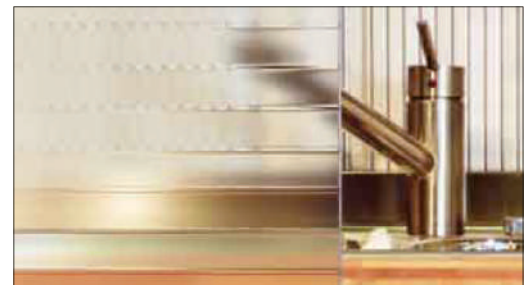

TIRADORES | HANDLES | POIGNÉES



CUBIC

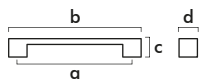

a	b	c	d		Cod.
224	250	22	25	Cromo mate Matt chrome Chrome mat	800098
160	200	22	25	Cromo mate Matt chrome Chrome mat	800100

GLASS

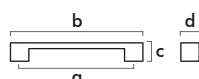

a	b	c	d		Cod.
160	174	25	20	Cromo look Look chrome Chrome look	800036

FINE

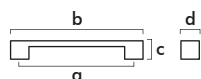

a	b	c	d		Cod.
160	175	35	10	Cromo mate Matt chrome Chrome mat	800116
192	205	35	10	Cromo mate Matt chrome Chrome mat	800117

2600

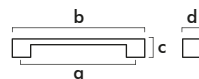

a	b	c	d		Cod.
128	152	30	20	Cromo mate Matt chrome Chrome mat	800001

LOW

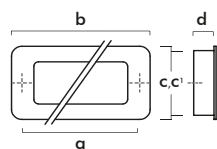

a	b	c, c'	d		Cod.
192	206	52-47	13.5	Cromo brillo Shining chrome Chrome brillant	802013
192	206	52-47	13.5	Níquel cepillado Brushed níquel Níquel brossé	802014

HIDE



a	b	c	d		Cod.
128	200	16,5	17,4	Cromo look Look chrome Chrome look	802010

2395 VITRINA ALUMINIO P4

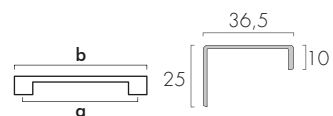

a	b		Cod.
192	216	Aluminio Aluminum Aluminium	809001

2478 VITRINA ALUMINIO P4 INTEGRADO

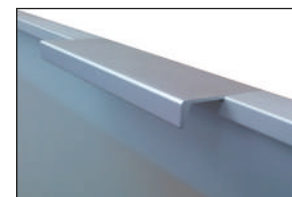
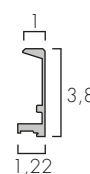
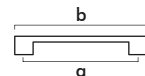

a	b		Cod.
126	-	Aluminio Aluminum Aluminium	809002

400



a	b	c	d		Cod.
160	180	35	15	Aluminio Aluminum Aluminium	800085
192	212	35	15	Aluminio Aluminium Aluminium	800086

1005



a	b	c	d		Cod.
192	242	32	10	Aluminio Aluminum Aluminium	800043

ARCH



a	b	c	d		Cod.
192	209	36	15	Cromo brillo Shining chrome Chrome brillant	800174
192	209	36	15	Níquel cepillado Brushed nickel Níquel brossé	800175

SENSE



a	b	c	d		Cod.
192	199	30	25	Cromo brillo Shining chrome Chrome brillant	800180
192	199	30	25	Inox look Inox look Inox look	800181
192	199	30	25	Negro cepillado Brushed black Noir brossé	800182

U056



a	b	c	d		Cod.
192	200	8,5	28,5	Níquel cepillado Brushed nickel Níquel brossé	800202
192	200	8,5	28,5	Latón cepillado Brushed brass Laiton brossé	800206
192	200	8,5	28,5	Negro mate Black matt Noir mat	800205
192	200	8,5	28,5	Blanco mate White matt Blanc mat	800204
192	200	8,5	28,5	Titanio Titanium Titane	800208

FLOID



a	b	c	d		Cod.
192	207,6	31	15,6	Oro cepillado Brushed gold Or brossé	800275
192	207,6	31	15,6	Plata Peltre Silver Peltre Argent Peltre	800276
192	207,6	31	15,6	Negro mate Black matt Noir mat	800277

ARROW



a	b	c	d		Cod.
192	223	36	20	Cromo brillo Shining chrome Chrome brillant	800176
192	223	36	20	Níquel cepillado Brushed nickel Níquel brossé	800177

BICOLOR 850



a	b	c	d		Cod.
160	178	12	25	Blanco, negro, níquel satinado, cobre White, black, satin Nickel, copper Blanc, noir, nickel satiné, cuivre	800241

Nota: ver combinaciones de color / Note: see color combinations / Remarque: voir combinaisons de couleurs

GRAFF 430

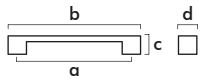

a	b	c	d		Cod.
160	182	33	10	Negro cepillado	800281
1178	1200	33	10	Brushed black Brossé noir	800282
160	182	33	10	Latón cepillado	800285
1178	1200	33	10	Brushed brass Laiton brossé	800286

POMO T GRAFF 430



a	b	c	d		Cod.
60	33	-	-	Negro cepillado	801038
				Brushed black Brossé noir	
60	33	-	-	Latón cepillado	801039
				Brushed brass Laiton brossé	

BARRA ACERO INOX

a	b	c	d		Cod.
128	192	32	12		803001
160	224	32	12		192
192	256	32	12		224
242	306	32	12		256
292	356	32	12		306
342	406	32	12		356
392	456	32	12		406
492	556	32	12		456
592	656	32	12		556
692	756	32	12		656
792	856	32	12		756
1092	1156	32	12		856
1192	1256	32	12		1156
					1256



Inox

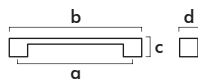

BRAVE 452

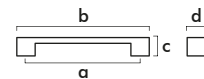

a	b	c	d		Cod.
192	240	26	8	Blanco White Blanc	800253
192/992	1040	33	8		800263
192	240	26	8	Negro Black Noir	800254
192/992	1040	33	8		800264
192	240	26	8	Metal Marrón Brown Metal	800259
192/992	1040	33	8	Métal brun	800269

VANN 375

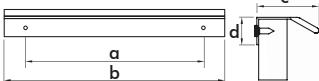

a	b	c	d		Cod.
128	200	44	19,7	Inox look	800552
				Inox look Inox look	
128	200	44	19,7	Latón cepillado	800526
				Brushed brass Laiton brossé	
128	200	44	19,7	Negro mate	800525
				Black matt Noir mat	

CUTT 322

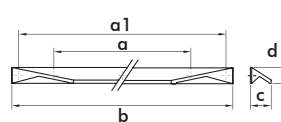

a	a1	b	c	d		Cod.
96	128	200	23	17,5	Inox look	800512
					Inox look Inox look	
96	128	200	23	17,5	Negro mate	800515
					Black matt Noir mat	

WALLACE 0503

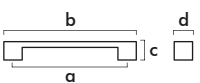

a	b	c	d		Cod.
128	210	15,8	30,7	Cromo brillo	802541
				Shiny chrome Chrome brillant	
128	210	15,8	30,7	Níquel negro brillo	802545
				Shiny black nickel Nickel noir b.	
128	210	15,8	30,7	Latón brillo	802546
				Glossy brass Laiton brillant	

REDO 226

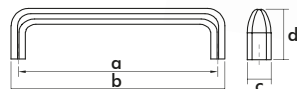

a	b	c	d		Cod.
192	201	15	32	Cobre cepillado	800216
				Brushed copper Bronze brossé	
192	201	15	32	Negro peltre	800215
				Black pewter Noir étain	

CLASSIC 348

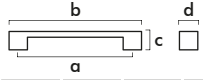

a	b	c	d		Cod.
160	170	26	24		Bronce viejo Aged bronze Bronze vieille 800235
160	170	26	24		Plata vieja Old silver Vieil argent 800236
160	170	26	24		Cobre rústico Rustic copper Cuivre rustique 800237

CLASSIC 349

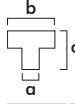

a	b	c	d		Cod.
16	35	28	-		Bronce viejo Aged bronze Bronze vieille 801035
16	35	28	-		Plata vieja Old silver Vieil argent 801036
16	35	28	-		Cobre rústico Rustic copper Cuivre rustique 801037

7372

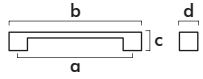

a	b	c	d		Cod.
96	137	28	20		Níquel negro cepillado Brushed black nickel Níquel brossé noir 800061

8841



a	b	c	d		Cod.
-	35	25	-		Níquel negro cepillado Brushed black nickel Níquel brossé noir 801016

9822

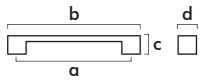

a	b	c	d		Cod.
96	137	28	20		Rústico bronce porcelana craquele Rusty bronze cracked porcelain Bronze rustique porcelaine craquelé 800062

9831



a	b	c	d		Cod.
-	35	25	-		Rústico bronce porcelana craquele Rusty bronze cracked porcelain Bronze rustique porcelaine craquelé 801015

AVA 394

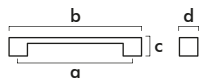
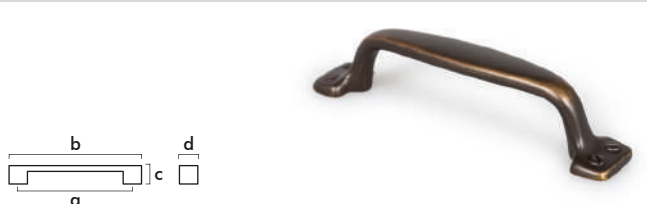

a	b	c	d		Cod.
96	128,5	29	26		Peltre Peltre Peltre 800271
96	128,5	29	26		Latón antiguo Antique brass Cuivre rustique 800270

PETRA

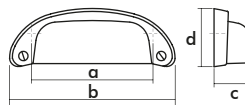
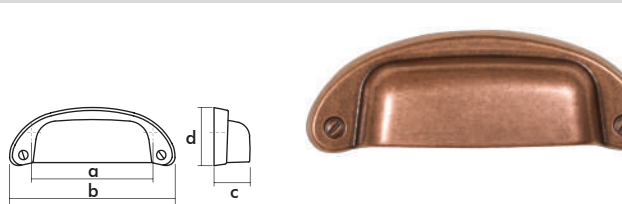

a	b	c	d		Cod.
64	97	19	34,5		Plata antigua Antique silver Argent ancien 802020
64	97	19	34,5		Cobre antiguo Antique copper Bronze ancien 802021
64	97	19	34,5		Negro mate Black matt Noir mat 802022

S140 LINEAR

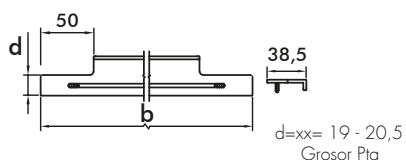

	b	c	d		Cod.
	148	10	19 - 20,5		803140
15	148	10	19 - 20,5		15 - xx
20	198	10	19 - 20,5		20 - xx
25	248	10	19 - 20,5		25 - xx
30	298	10	19 - 20,5		30 - xx
35	348	10	19 - 20,5		35 - xx
40	398	10	19 - 20,5		40 - xx
45	448	10	19 - 20,5		45 - xx
50	498	10	19 - 20,5		50 - xx
60	598	10	19 - 20,5		60 - xx
70	698	10	19 - 20,5		70 - xx
80	798	10	19 - 20,5		80 - xx
90	898	10	19 - 20,5		90 - xx
100	998	10	19 - 20,5		100 - xx
120	1198	10	19 - 20,5		120 - xx

Inox | Inox | Inox

S250 FORMA

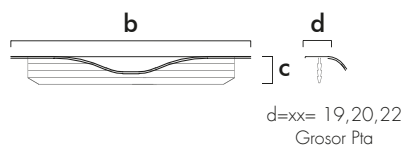

	b	c	d		Cod.
	147	10	19 - 20 - 22		803250
15	147	10	19 - 20 - 22		15 - xx
20	197	10	19 - 20 - 22		20 - xx
25	247	10	19 - 20 - 22		25 - xx
30	297	10	19 - 20 - 22		30 - xx
35	347	10	19 - 20 - 22		35 - xx
40	397	10	19 - 20 - 22		40 - xx
45	447	10	19 - 20 - 22		45 - xx
50	497	10	19 - 20 - 22		50 - xx
60	597	10	19 - 20 - 22		60 - xx
70	697	10	19 - 20 - 22		70 - xx
80	797	10	19 - 20 - 22		80 - xx
90	897	10	19 - 20 - 22		90 - xx
100	997	10	19 - 20 - 22		100 - xx
120	1197	10	19 - 20 - 22		120 - xx

Inox | Inox | Inox

S340 GRADA

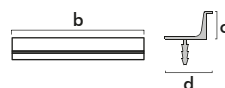

	b	c	d		Cod.
15	147	11	16		Aluminio Aluminum Aluminium
20	197	11	16		803340
25	247	11	16		Inox look Inox look Inox look
30	297	11	16		803342
35	347	11	16		Blanco White Blanc
40	397	11	16		803343
45	447	11	16		Negro Black Noir
50	497	11	16		803344
60	597	11	16		
70	697	11	16		
80	797	11	16		
90	897	11	16		
100	997	11	16		
120	1197	11	16		

S400

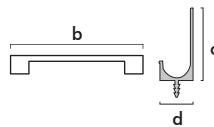

h	b	c	d
30	298	35	16
35	348	35	16
40	398	35	16
45	448	35	16
50	498	35	16
60	598	35	16
70	698	35	16
80	798	35	16
90	898	35	16
100	998	35	16
120	1118	35	16
130	1218	35	16
250	2418	35	16

Cod.	Color	Finish
803410	Aluminio mate Matt Aluminum Aluminium Mat	
803411	Cromo brillo Shining chrome Chrome brillant	
803412	Inox Inox Inox	
803413	Blanco mate Matt white Blanc mat	
803414	Negro mate Matt Black Noir mat	

S401

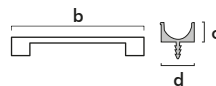

h	b	c	d
30	298	9,2	16
35	348	9,2	16
40	398	9,2	16
45	448	9,2	16
50	498	9,2	16
60	598	9,2	16
70	698	9,2	16
80	798	9,2	16
90	898	9,2	16
100	998	9,2	16
120	1118	9,2	16
130	1218	9,2	16
250	2418	9,2	16

Cod.	Color	Finish
803420	Aluminio mate Matt aluminum Aluminium mat	
803421	Cromo brillo Shining chrome Chrome brillant	
803422	Inox Inox Inox	
803423	Blanco mate Matt white Blanc mat	
803424	Negro mate Matt black Noir mat	

SERIE GOLA

GOLA - PERFIL J

GOLA - PROFILE J | GOLA - PROFIL J



a†	b	c			Cod.
57	4 Mts	26	Aluminio Aluminum Aluminium		400 A
57	4 Mts	26	Blanco White Blanc		400 B
57	4 Mts	26	Negro Black Noir		400 N
57	4 Mts	26	Oro Grata Grata Gold Or Grata		400 O

GOLA - PERFIL U

GOLA - PROFILE U | GOLA - PROFIL U



a†	b	c			Cod.
72	4 Mts	26	Aluminio Aluminum Aluminium		400 A
72	4 Mts	26	Blanco White Blanc		400 B
72	4 Mts	26	Negro Black Noir		400 N
72	4 Mts	26	Oro Grata Grata Gold Or Grata		400 O

GOLA - PERFIL VERTICAL DOBLE

GOLA - PROFILE VERTICAL DOUBLE | GOLA - PROFIL VERTICAL DOUBLER

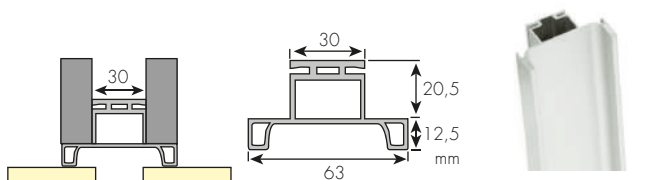

a†	b	c			Cod.
4,6 Mts	63	12,5	Aluminio Aluminum Aluminium		460 A
4,6 Mts	63	12,5	Blanco White Blanc		460 B
4,6 Mts	63	12,5	Negro Black Noir		460 N
4,6 Mts	63	12,5	Oro Grata Grata Gold Or Grata		460 O

GOLA - PERFIL VERTICAL SIMPLE

GOLA - PROFILE VERTICAL SIMPLE | GOLA - PROFIL VERTICAL SIMPLES

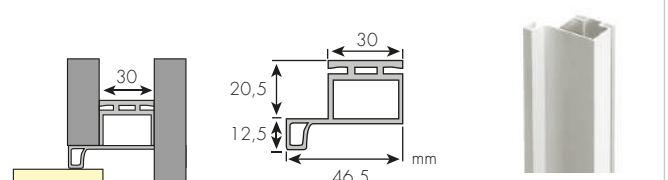

a†	b	c			Cod.
4,6 Mts	46,5	12,5	Aluminio Aluminum Aluminium		460 A
4,6 Mts	46,5	12,5	Blanco White Blanc		460 B
4,6 Mts	46,5	12,5	Negro Black Noir		460 N
4,6 Mts	46,5	12,5	Oro Grata Grata Gold Or Grata		460 O

GOLA - RINCON PERFIL J / ESQUINA PERFIL J

INSIDE / OUTSIDE CORNER | COIN EXTERNE / INTÉRIEUR

Rincón | Inside | Intérieur

a†	b			Cod.
57	29	Aluminio Aluminum Aluminium		803921 - A
57	29	Blanco White Blanc		803921 - B
57	29	Negro Black Noir		803921 - N
57	29	Oro Grata Grata Gold Or Grata		803921 - O

Esquina | Outside | Extérieur

a†	b			Cod.
57	27	Aluminio Aluminum Aluminium		803922 - A
57	27	Blanco White Blanc		803922 - B
57	27	Negro Black Noir		803922 - N
57	27	Oro Grata Grata Gold Or Grata		803922 - O

GOLA - JUEGO TAPA PERFIL J / U

GOLA - PROFILE J/U COVER SET | GOLA - JEU CAPS PROFIL J/U

a†	b	c			Cod.
57	26	1,5	Aluminio Aluminum Aluminium		803931 - A
57	26	1,5	Blanco White Blanc		803931 - B
57	26	1,5	Negro Black Noir		803931 - N
57	26	1,5	Oro Grata Grata Gold Or Grata		803931 - O



a†	b	c			Cod.
72	26	1,5	Aluminio Aluminum Aluminium		803932 - A
72	26	1,5	Blanco White Blanc		803932 - B
72	26	1,5	Negro Black Noir		803932 - N
72	26	1,5	Oro Grata Grata Gold Or Grata		803932 - O



GOLA - KIT FIJACIÓN

GOLA - FIXING KIT | GOLA - KIT DE FIXATION



Cod.
803911

SERIE GOLA PLANO

GOLA - PERFIL HORIZONTAL PLANO J

GOLA - PROFILE FLAT J | GOLA - PROFIL PLAT J

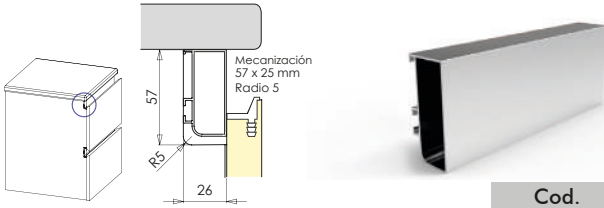

a†	b	C				Cod.
57	4 Mts	26	Aluminio Aluminum Aluminium		400	A
57	4 Mts	26	Blanco White Blanc		400	B
57	4 Mts	26	Negro Black Noir		400	N
57	4 Mts	26	Oro Grata Grata Gold Or Grata		400	O

GOLA - PERFIL HORIZONTAL PLANO U

GOLA - PROFILE FLAT U | GOLA - PROFIL PLAT U

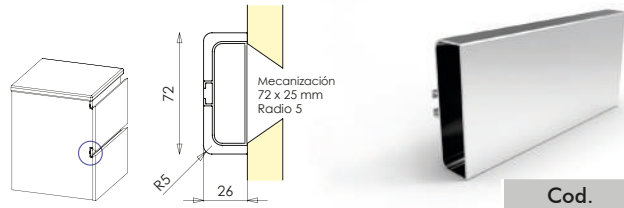

a†	b	C				Cod.
72	4 Mts	26	Aluminio Aluminum Aluminium		400	A
72	4 Mts	26	Blanco White Blanc		400	B
72	4 Mts	26	Negro Black Noir		400	N
72	4 Mts	26	Oro Grata Grata Gold Or Grata		400	O

GOLA - PERFIL VERTICAL PLANO DOBLE

GOLA - PROFILE VERTICAL FLAT DOUBLE | GOLA - PROFIL VERTICAL PLAT DOUBLER



a†	b	C				Cod.
4,7 Mts	63	12,5	Aluminio Aluminum Aluminium		460	A
4,7 Mts	63	12,5	Blanco White Blanc		460	B
4,7 Mts	63	12,5	Negro Black Noir		460	N
4,7 Mts	63	12,5	Oro Grata Grata Gold Or Grata		460	O

GOLA - PERFIL VERTICAL PLANO SIMPLE

GOLA - PROFILE VERTICAL FLAT SIMPLE | GOLA - PROFIL VERTICAL PLAT SIMPLES

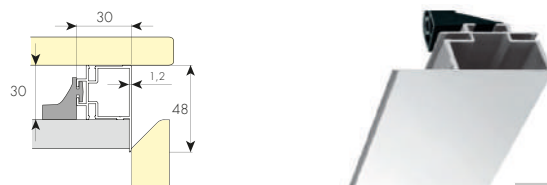

a†	b	C				Cod.
4,7 Mts	46,5	12,5	Aluminio Aluminum Aluminium		460	A
4,7 Mts	46,5	12,5	Blanco White Blanc		460	B
4,7 Mts	46,5	12,5	Negro Black Noir		460	N
4,7 Mts	46,5	12,5	Oro Grata Grata Gold Or Grata		460	O

GOLA PLANO - CROQUIS DE INSTALACIÓN VERTICAL

GOLA FLAT - SKETCH OF INSTALLATION VERTICAL
GOLA PLAT - CROQUIS DE L'INSTALLATION VERTICALE

GOLA - PERFIL PLANO SIMPLE

GOLA - PROFILE FLAT SIMPLE
GOLA - PROFIL PLAT SIMPLES

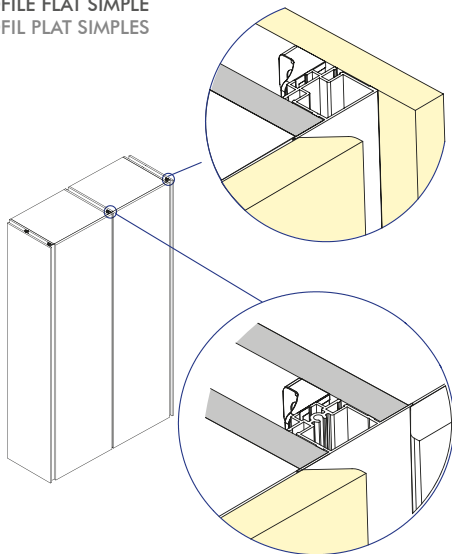

GOLA - PERFIL PLANO DOBLE

GOLA - PROFILE FLAT DOUBLE
GOLA - PROFIL PLAT DOUBLER

GOLA - KIT FIJACIÓN PERFIL SIMPLE

GOLA - FIXING KIT PROFILE SIMPLE | GOLA - KIT DE FIXATION PROFIL SIMPLES



Cod.
803912

NEW

GOLA - PERFIL ALTO

GOLA - PROFILE HIGH | GOLA - PROFIL ÉLEVÉ

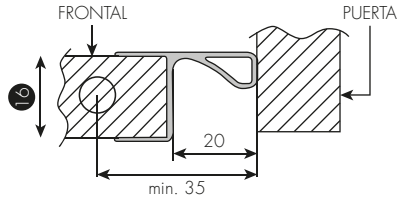
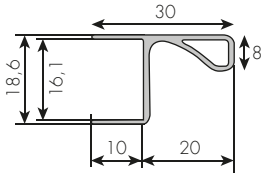
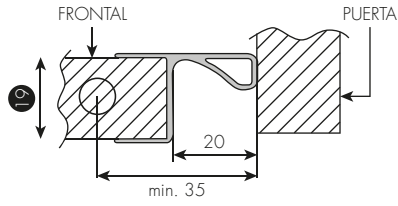
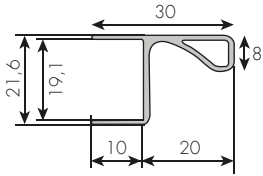

				Cod.	
a†	b	c/		803905	
16	4,1 Mts	22	Aluminio Aluminum Aluminium		300 A16
16	4,1 Mts	22	Blanco White Blanc		300 B16
19	4,1 Mts	22	Blanco White Blanc		300 B19
19	4,1 Mts	22	Antracita Anthracite Anthracite		300 AT19

CAJONES | DRAWERS | TIROIRS



SERIE NOVA PRO SCALA

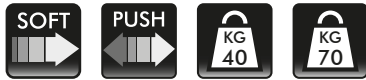

CARACTERÍSTICAS GENERALES **i**

La SERIE NOVA PRO SCALA destaca por la óptica moderna y simple de los laterales Deluxe y su aprovechamiento del espacio único. Nova Pro Scala inspiración hasta en los detalles. Integra la guía Soft-Close de extracción total. Disponible en colores blanco, gris y antracita.

NOVA SCALA PRO SERIES characterized by an optics simple and modern of the Deluxe drawer sides and unique space utilization. Nova Pro Scala inspiration in every detail, integrates Soft-Close full extraction guide. Available in gray, white and anthracite.

La SERIE NOVA PRO SCALA mis en évidence par les parties optiques, modernes, simples et leur utilisation de l'espace d'inspiration dans les moindres d'étails. Intègre la guide Soft-close d'extraction total. Disponible en couleur grise, blanc y anthracite.

- * EN STOCK PERMANENTE
- * IN PERMANENT STOCK
- * EN STOCK PERMANENT

SERIE NOVA XP



CARACTERÍSTICAS GENERALES **i**

Nuevo cajón de un diseño elegante con laterales de doble pared. Destinado a clientes exigentes. Disponible en colores blanco y antracita.

New drawer with an elegant design with double-walled sides. Intended for demanding clients. Available in white and anthracite colors.

Nouveau tiroir au design élégant avec côtés à double paroi. Destiné aux clients exigeants. Disponible dans les couleurs blanc et anthracite.

- * EN STOCK PERMANENTE
- * IN PERMANENT STOCK
- * EN STOCK PERMANENT

SERIE GRASS VIONARO



CARACTERÍSTICAS GENERALES

La nueva serie VIONARO destaca por su belleza y precisión de movimiento, con la garantía de una gran marca.
Disponibile en blanco y antracita.

The new VIONARO series stands out for its beauty and precision of movement, with the guarantee of a great brand.
Available in white and anthracite.

La nouvelle série VIONARO se distingue par sa beauté et sa précision de mouvement, avec la garantie d'une grande marque.
Disponibile en blanc et anthracite.

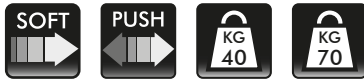

- * DISPONIBILIDAD BAJO PEDIDO
- * AVAILABILITY ON REQUEST
- * DISPONIBLE SUR COMMANDE

COMPLEMENTOS GRASS



SERIE NOVA PRO SCALA



CARACTERÍSTICAS GENERALES i

La SERIE NOVA PRO SCALA con extracción total, oculta y controlada, tiene un deslizamiento ligero durante toda la vida útil del mueble. Gualderas de acero en acabado blanco, gris y antracita. Con la guía Nova Pro integrada, se logra que los cajones se cierren de forma suave y silenciosa.

NOVA PRO SCALA SERIES with full extraction, hide and controlled, has a slight slip during the lifetime of the cabinet. Steel drawer sides with silk white, gray and anthracite finish. Nova Pro guide integrated to get the drawers to close gently and silently.

La SERIE NOVA PRO SCALA avec extraction total, cachée et contrôlée, a un léger glissement pour toute une vie du meuble. Lisses en acier avec finition blanc, gray et anthracite. Avec la guide de Nova Pro intégré, pour obtenir que les tiroirs se ferment doucement et silencieusement.

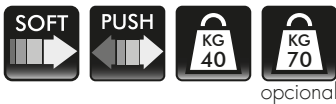

xx = CÓDIGO ACABADO - BLANCO B, GRIS G, ANTRACITA A
xx = FINISHED CODE - WHITE B, GRAY G, ANTHRACITE A
xx = CODE FINITION - BLANC B, GRAY G, ANTHRACITE A

NOVA PRO SCALA - CAJÓN

NOVA PRO SCALA - DRAWER | NOVA PRO SCALA - TIROIR

- 1 Laterales H90 Pro Scala
- 2 Guías Pro Scala ext. total
- 3 Ganchos suspensión
- 4 Soporte trasera
- 5 Set fijación frontal
- 6 Base y trasera melamina

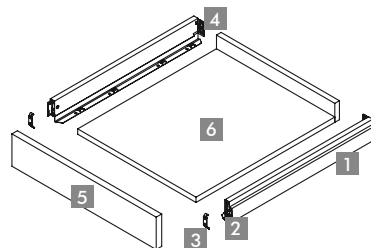

	Cod. 815901					
	↖ 50		↖ 40		↖ 27	
30	3050	xx	3040	xx	3030	xx
35	3550	xx	3540	xx	3530	xx
40	4050	xx	4040	xx	4030	xx
45	4550	xx	4540	xx	4530	xx
50	5050	xx	5040	xx	5030	xx
60	6050	xx	6040	xx	6030	xx
70	7050	xx	7040	xx	7030	xx
80	8050	xx	8040	xx	8030	xx
90	9050	xx	9040	xx	9030	xx
100	10050	xx	10040	xx	10030	xx
120	12050	xx	12040	xx	12030	xx

NOVA PRO SCALA - CACEROLERO

NOVA PRO SCALA - PAN DRAWER | NOVA PRO SCALA - COFFRE

- 1 Laterales H90 Pro Scala
- 2 Guías Pro Scala ext. total
- 3 Ganchos suspensión
- 4 Soporte trasera
- 5 Set fijación frontal
- 6 Base y trasera melamina

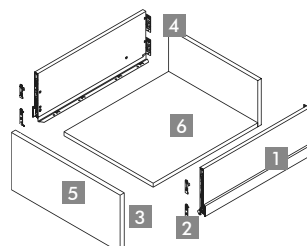
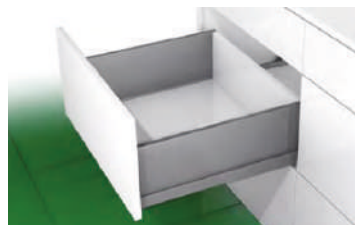

	Cod. 815903					
	↖ 50		↖ 40		↖ 27	
30	3050	xx	3040	xx	3030	xx
35	3550	xx	3540	xx	3530	xx
40	4050	xx	4040	xx	4030	xx
45	4550	xx	4540	xx	4530	xx
50	5050	xx	5040	xx	5030	xx
60	6050	xx	6040	xx	6030	xx
70	7050	xx	7040	xx	7030	xx
80	8050	xx	8040	xx	8030	xx
90	9050	xx	9040	xx	9030	xx
100	10050	xx	10040	xx	10030	xx
120	12050	xx	12040	xx	12030	xx

NOVA PRO SCALA - CACEROLERO CRISTAL

NOVA PRO SCALA - GLASS PAN DRAWER | NOVA PRO SCALA - COFFRE CRISTAL

- 1 Laterales H94 Pro Scala
- 2 Ganchos y soportes frente
- 3 Ganchos suspensión
- 4 Set cristal lateral
- 5 Soporte trasera
- 6 Set fijación frontal
- 7 Base y trasera melamina

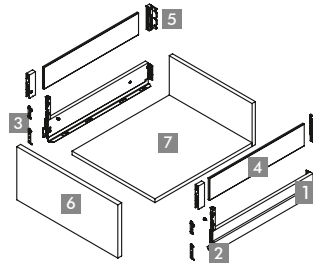

C	Cod. 815905					
	↙ 50		↙ 40		↙ 27	
30	3050	xx	3040	xx	3030	xx
35	3550	xx	3540	xx	3530	xx
40	4050	xx	4040	xx	4030	xx
45	4550	xx	4540	xx	4530	xx
50	5050	xx	5040	xx	5030	xx
60	6050	xx	6040	xx	6030	xx
70	7050	xx	7040	xx	7030	xx
80	8050	xx	8040	xx	8030	xx
90	9050	xx	9040	xx	9030	xx
100	10050	xx	10040	xx	10030	xx
120	12050	xx	12040	xx	12030	xx

NOVA PRO SCALA - CAJÓN INTERIOR

NOVA PRO SCALA - INNER DRAWER | NOVA PRO SCALA - TIROIR INTÉRIEUR

- 1 Laterales H90 Pro Scala
- 2 Guías Pro Scala ext. total
- 3 Ganchos suspensión
- 4 Soporte trasera
- 5 Set fijación frontal
- 6 Base y trasera melamina

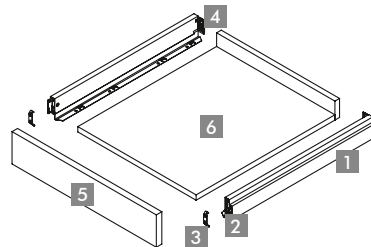
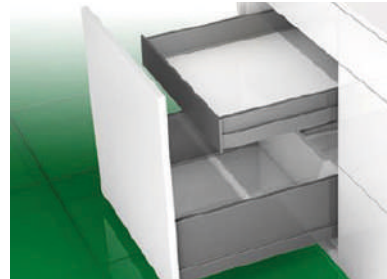

C	Cod. 815902					
	↙ 50		↙ 40		↙ 27	
30	3050	xx	3040	xx	3030	xx
35	3550	xx	3540	xx	3530	xx
40	4050	xx	4040	xx	4030	xx
45	4550	xx	4540	xx	4530	xx
50	5050	xx	5040	xx	5030	xx
60	6050	xx	6040	xx	6030	xx
70	7050	xx	7040	xx	7030	xx
80	8050	xx	8040	xx	8030	xx
90	9050	xx	9040	xx	9030	xx
100	10050	xx	10040	xx	10030	xx
120	12050	xx	12040	xx	12030	xx

NOVA PRO SCALA - CACEROLERO INTERIOR

NOVA PRO SCALA - INNER PAN DRAWER | NOVA PRO SCALA - COFFRE INTÉRIEUR

- 1 Laterales H186 Pro Scala
- 2 Guías Pro Scala ext. total
- 3 Ganchos suspensión
- 4 Soporte trasera
- 5 Set fijación frontal
- 6 Base y trasera melamina

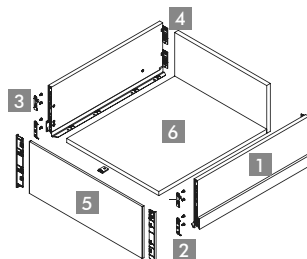
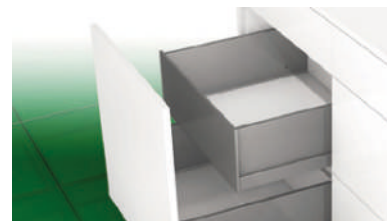

C	Cod. 815904					
	↙ 50		↙ 40		↙ 27	
30	3050	xx	3040	xx	3030	xx
35	3550	xx	3540	xx	3530	xx
40	4050	xx	4040	xx	4030	xx
45	4550	xx	4540	xx	4530	xx
50	5050	xx	5040	xx	5030	xx
60	6050	xx	6040	xx	6030	xx
70	7050	xx	7040	xx	7030	xx
80	8050	xx	8040	xx	8030	xx
90	9050	xx	9040	xx	9030	xx
100	10050	xx	10040	xx	10030	xx
120	12050	xx	12040	xx	12030	xx

NOVA PRO SCALA - CACEROLERO INTERIOR CRISTAL

NOVA PRO SCALA - INNER GLASS PAN DRAWER | NOVA PRO SCALA - COFFRE INTÉRIEUR CRISTAL

- 1 Laterales H94 Pro Scala
- 2 Ganchos y soportes frente
- 3 Ganchos suspensión
- 4 Set cristal lateral
- 5 Soporte trasera
- 6 Set fijación frontal
- 7 Base y trasera melamina

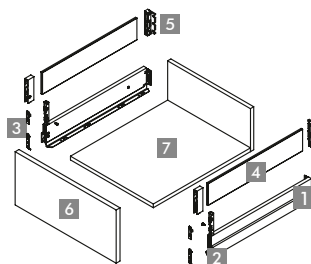

	Cod. 815906					
	↙ 50		↙ 40		↙ 27	
30	3050	xx	3040	xx	3030	xx
35	3550	xx	3540	xx	3530	xx
40	4050	xx	4040	xx	4030	xx
45	4550	xx	4540	xx	4530	xx
50	5050	xx	5040	xx	5030	xx
60	6050	xx	6040	xx	6030	xx
70	7050	xx	7040	xx	7030	xx
80	8050	xx	8040	xx	8030	xx
90	9050	xx	9040	xx	9030	xx
100	10050	xx	10040	xx	10030	xx
120	12050	xx	12040	xx	12030	xx

NOVA PRO SCALA - CAJÓN PUSH TIPMATIC PLUS

NOVA PRO SCALA - PUSH TIPMATIC PLUS DRAWER | NOVA PRO SCALA - TIROIR PUSH TIPMATIC PLUS

- 1 Laterales H90 Pro Scala
- 2 Guías Pro Scala ext. total
- 3 Ganchos suspensión
- 4 Soporte trasera
- 5 Set fijación frontal
- 6 Base y trasera melamina

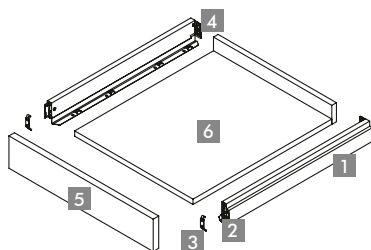

	Cod. 815901					
	↙ 50		↙ 40		↙ 27	
30	3050	Pxx	3040	Pxx	3030	Pxx
35	3550	Pxx	3540	Pxx	3530	Pxx
40	4050	Pxx	4040	Pxx	4030	Pxx
45	4550	Pxx	4540	Pxx	4530	Pxx
50	5050	Pxx	5040	Pxx	5030	Pxx
60	6050	Pxx	6040	Pxx	6030	Pxx
70	7050	Pxx	7040	Pxx	7030	Pxx
80	8050	Pxx	8040	Pxx	8030	Pxx
90	9050	Pxx	9040	Pxx	9030	Pxx
100	10050	Pxx	10040	Pxx	10030	Pxx
120	12050	Pxx	12040	Pxx	12030	Pxx

NOVA PRO SCALA - CACEROLERO PUSH TIPMATIC PLUS

NOVA PRO SCALA - PUSH TIPMATIC PLUS PAN DRAWER | NOVA PRO SCALA - PUSH TIPMATIC PLUS COFFRE

- 1 Laterales H90 Pro Scala
- 2 Guías Pro Scala ext. total
- 3 Ganchos suspensión
- 4 Soporte trasera
- 5 Set fijación frontal
- 6 Base y trasera melamina

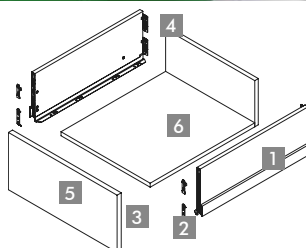

	Cod. 815903					
	↙ 50		↙ 40		↙ 27	
30	3050	Pxx	3040	Pxx	3030	Pxx
35	3550	Pxx	3540	Pxx	3530	Pxx
40	4050	Pxx	4040	Pxx	4030	Pxx
45	4550	Pxx	4540	Pxx	4530	Pxx
50	5050	Pxx	5040	Pxx	5030	Pxx
60	6050	Pxx	6040	Pxx	6030	Pxx
70	7050	Pxx	7040	Pxx	7030	Pxx
80	8050	Pxx	8040	Pxx	8030	Pxx
90	9050	Pxx	9040	Pxx	9030	Pxx
100	10050	Pxx	10040	Pxx	10030	Pxx
120	12050	Pxx	12040	Pxx	12030	Pxx

NOVA PRO SCALA - CACEROLERO CRISTAL PUSH TIPMATIC PLUS

NOVA PRO SCALA - PUSH TIPMATIC PLUS GLASS PAN DRAWER | NOVA PRO SCALA - COFFRE CRISTAL PUSH TIPMATIC PLUS

- 1 Laterales H94 Pro Scala
- 2 Ganchos y soportes frente
- 3 Ganchos suspensión
- 4 Set crital lateral
- 5 Soporte trasera
- 6 Set fijación frontal
- 7 Base y trasera melamina

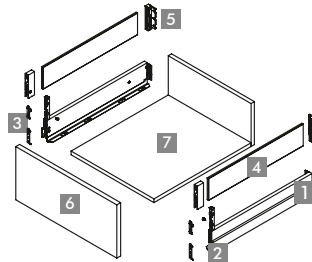

	Cod. 815905					
	↙ 50		↙ 40		↙ 27	
30	3050	Pxx	3040	Pxx	3030	Pxx
35	3550	Pxx	3540	Pxx	3530	Pxx
40	4050	Pxx	4040	Pxx	4030	Pxx
45	4550	Pxx	4540	Pxx	4530	Pxx
50	5050	Pxx	5040	Pxx	5030	Pxx
60	6050	Pxx	6040	Pxx	6030	Pxx
70	7050	Pxx	7040	Pxx	7030	Pxx
80	8050	Pxx	8040	Pxx	8030	Pxx
90	9050	Pxx	9040	Pxx	9030	Pxx
100	10050	Pxx	10040	Pxx	10030	Pxx
120	12050	Pxx	12040	Pxx	12030	Pxx

NOVA PRO SCALA - CAJÓN INTERIOR PUSH TIPMATIC PLUS

NOVA PRO SCALA - PUSH TIPMATIC PLUS INNER DRAWER | NOVA PRO SCALA - TIROIR INTÉRIEUR PUSH TIPMATIC PLUS

- 1 Laterales H90 Pro Scala
- 2 Guías Pro Scala ext. total
- 3 Ganchos suspensión
- 4 Soporte trasera
- 5 Set fijación frontal
- 6 Base y trasera melamina

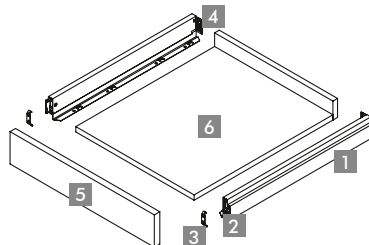

	Cod. 815902					
	↙ 50		↙ 40		↙ 27	
30	3050	Pxx	3040	Pxx	3030	Pxx
35	3550	Pxx	3540	Pxx	3530	Pxx
40	4050	Pxx	4040	Pxx	4030	Pxx
45	4550	Pxx	4540	Pxx	4530	Pxx
50	5050	Pxx	5040	Pxx	5030	Pxx
60	6050	Pxx	6040	Pxx	6030	Pxx
70	7050	Pxx	7040	Pxx	7030	Pxx
80	8050	Pxx	8040	Pxx	8030	Pxx
90	9050	Pxx	9040	Pxx	9030	Pxx
100	10050	Pxx	10040	Pxx	10030	Pxx
120	12050	Pxx	12040	Pxx	12030	Pxx

NOVA PRO SCALA - CACEROLERO INTERIOR PUSH TIPMATIC PLUS

NOVA PRO SCALA - PUSH TIPMATIC PLUS INNER PAN DRAWER | NOVA PRO SCALA - COFFRE INTÉRIEUR PUSH TIPMATIC PLUS

- 1 Laterales H186 Pro Scala
- 2 Guías Pro Scala ext. total
- 3 Ganchos suspensión
- 4 Soporte trasera
- 5 Set fijación frontal
- 6 Base y trasera melamina

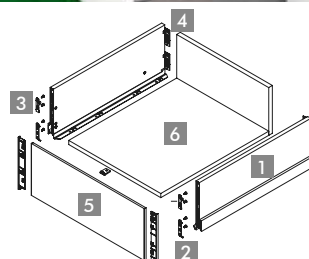

	Cod. 815904					
	↙ 50		↙ 40		↙ 27	
30	3050	Pxx	3040	Pxx	3030	Pxx
35	3550	Pxx	3540	Pxx	3530	Pxx
40	4050	Pxx	4040	Pxx	4030	Pxx
45	4550	Pxx	4540	Pxx	4530	Pxx
50	5050	Pxx	5040	Pxx	5030	Pxx
60	6050	Pxx	6040	Pxx	6030	Pxx
70	7050	Pxx	7040	Pxx	7030	Pxx
80	8050	Pxx	8040	Pxx	8030	Pxx
90	9050	Pxx	9040	Pxx	9030	Pxx
100	10050	Pxx	10040	Pxx	10030	Pxx
120	12050	Pxx	12040	Pxx	12030	Pxx

NOVA PRO SCALA - CACEROLERO INTERIOR CRISTAL PUSH TIPMATIC PLUS

NOVA PRO SCALA - PUSH TIPMATIC PLUS INNER GLASS PAN DRAWER | NOVA PRO SCALA - COFFRE INTÉRIEUR CRISTAL PUSH TIPMATIC PLUS

- 1 Laterales H94 Pro Scala
- 2 Ganchos y soportes frente
- 3 Ganchos suspensión
- 4 Set cristal lateral
- 5 Soporte trasera
- 6 Set fijación frontal
- 7 Base y trasera melamina

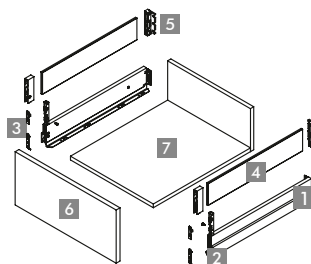

	Cod. 815906					
	50		40		27	
30	3050	Pxx	3040	Pxx	3030	Pxx
35	3550	Pxx	3540	Pxx	3530	Pxx
40	4050	Pxx	4040	Pxx	4030	Pxx
45	4550	Pxx	4540	Pxx	4530	Pxx
50	5050	Pxx	5040	Pxx	5030	Pxx
60	6050	Pxx	6040	Pxx	6030	Pxx
70	7050	Pxx	7040	Pxx	7030	Pxx
80	8050	Pxx	8040	Pxx	8030	Pxx
90	9050	Pxx	9040	Pxx	9030	Pxx
100	10050	Pxx	10040	Pxx	10030	Pxx
120	12050	Pxx	12040	Pxx	12030	Pxx



SERIE EKALINE



CARACTERÍSTICAS GENERALES i

Cajón con diseño moderno y laterales extra finos, proporcionando una mayor capacidad interior. Con guías de 40 kg. ocultas soft close de extracción total. Suministro estándar en color blanco y antracita.

Drawer with modern design and extra slim side, providing a bigger interior capacity. With hidden guides supporting 40 kg. soft close and total extraction. In white and anthracite colour.

Tiroir au design moderne avec latéraux extra fins, offrant une capacité intérieure supérieure. Avec coulisses de 40kg invisibles soft close d'extraction totale. Livraison standard en couleur blanc et anthracite.



EKALINE - CAJÓN

EKALINE - DRAWER | EKALINE - TIROIR

- 1 Gualdera H90 Ekaline
- 2 Guía Ekaline ext. total
- 3 Set fijación frontal
- 4 Adaptador trasera
- 5 Base y trasera melamina

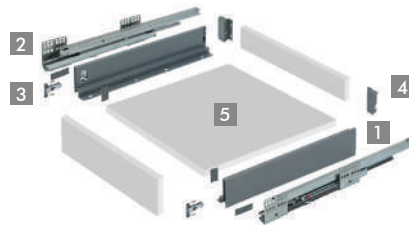

	Cod. 814292					
	50		40		30	
30	3050	A/B	3040	A/B	3030	A/B
35	3550	A/B	3540	A/B	3530	A/B
40	4050	A/B	4040	A/B	4030	A/B
45	4550	A/B	4540	A/B	4530	A/B
50	5050	A/B	5040	A/B	5030	A/B
60	6050	A/B	6040	A/B	6030	A/B
70	7050	A/B	7040	A/B	7030	A/B
80	8050	A/B	8040	A/B	8030	A/B
90	9050	A/B	9040	A/B	9030	A/B
100	10050	A/B	10040	A/B	10030	A/B
120	12050	A/B	12040	A/B	12030	A/B

EKALINE - CACEROLERO

EKALINE - PAN DRAWER | EKALINE - COFFRE

- 1 Gualdera H180 Ekaline
- 2 Guía Ekaline ext. total
- 3 Set fijación frontal
- 4 Adaptador trasera
- 5 Base y trasera melamina

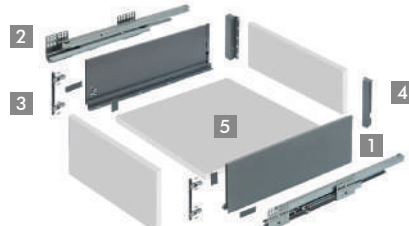
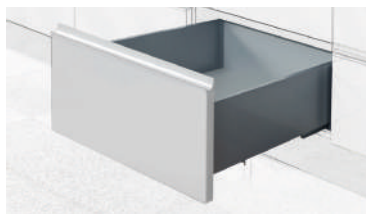

	Cod. 814293					
	50		40		30	
30	3050	A/B	3040	A/B	3030	A/B
35	3550	A/B	3540	A/B	3530	A/B
40	4050	A/B	4040	A/B	4030	A/B
45	4550	A/B	4540	A/B	4530	A/B
50	5050	A/B	5040	A/B	5030	A/B
60	6050	A/B	6040	A/B	6030	A/B
70	7050	A/B	7040	A/B	7030	A/B
80	8050	A/B	8040	A/B	8030	A/B
90	9050	A/B	9040	A/B	9030	A/B
100	10050	A/B	10040	A/B	10030	A/B
120	12050	A/B	12040	A/B	12030	A/B

EKALINE - CAJÓN INTERIOR

EKALINE - INNER DRAWER | EKALINE - TIROIR INTÉRIEUR

- 1 Gualdera H90 Ekaliné
- 2 Guía Ekaliné ext. total
- 3 Set fijación frontal
- 4 Adaptador trasera
- 5 Base y trasera melamina
- 6 Frente interior
- 7 Enganches y soportes

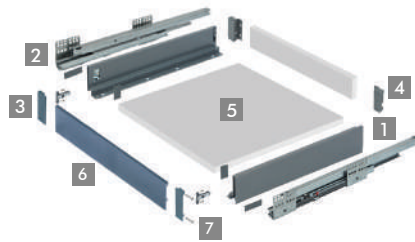
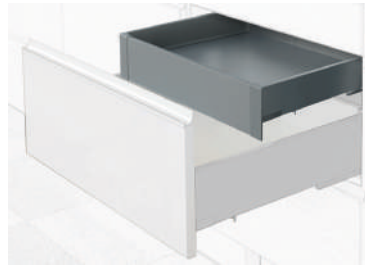

	Cod. 814295					
	↙ 50		↙ 40		↙ 30	
30	3050	A/B	3040	A/B	3030	A/B
35	3550	A/B	3540	A/B	3530	A/B
40	4050	A/B	4040	A/B	4030	A/B
45	4550	A/B	4540	A/B	4530	A/B
50	5050	A/B	5040	A/B	5030	A/B
60	6050	A/B	6040	A/B	6030	A/B
70	7050	A/B	7040	A/B	7030	A/B
80	8050	A/B	8040	A/B	8030	A/B
90	9050	A/B	9040	A/B	9030	A/B
100	10050	A/B	10040	A/B	10030	A/B
120	12050	A/B	12040	A/B	12030	A/B

EKALINE - CACEROLERO INTERIOR

EKALINE - INNER PAN DRAWER | EKALINE - COFFRE INTÉRIEUR

- 1 Gualdera H180 Ekaliné
- 2 Guía Ekaliné ext. total
- 3 Set fijación frontal
- 4 Adaptador trasera
- 5 Base y trasera melamina
- 6 Frente interior
- 7 Frente tirador
- 8 Enganches y soportes

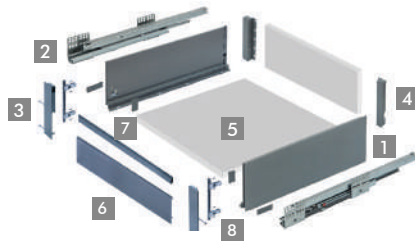

	Cod. 814296					
	↙ 50		↙ 40		↙ 30	
30	3050	A/B	3040	A/B	3030	A/B
35	3550	A/B	3540	A/B	3530	A/B
40	4050	A/B	4040	A/B	4030	A/B
45	4550	A/B	4540	A/B	4530	A/B
50	5050	A/B	5040	A/B	5030	A/B
60	6050	A/B	6040	A/B	6030	A/B
70	7050	A/B	7040	A/B	7030	A/B
80	8050	A/B	8040	A/B	8030	A/B
90	9050	A/B	9040	A/B	9030	A/B
100	10050	A/B	10040	A/B	10030	A/B
120	12050	A/B	12040	A/B	12030	A/B

SERIE NOVA XP



CARACTERÍSTICAS GENERALES i

La NOVA XP posee guías sincronizadas de extracción total y con la función de cierre Soft. Las guialderas de acero lacadas en blanco y en antracita, le proporcionan un acabado actual. De fácil montaje e integración en el mueble.

NOVA XP has full extension guides synchronized and soft close function. The steel drawer sides laquered on white and anthracite color, provide an actual finish. Easy installation and integration into the cabinet.

La NOVA XP a des guides d'extraction total synchronise avec fonction de fermeture en douceur Soft. Les lisses en acier peint en blanc et anthracite font une termaison actuelle, de facil montage dans le meuble.



NOVA XP - CAJÓN

NOVA XP - DRAWER | NOVA XP - TIROIR

- 1 Laterales H95 Nova XP
- 2 Guías Nova XP ext. total
- 3 Ganchos suspensión
- 4 Soporte trasera
- 5 Set fijación frontal
- 6 Base y trasera melamina

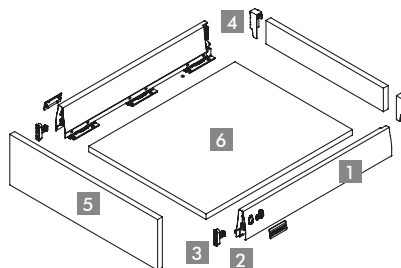

	Cod. 814192					
	↙ 50		↙ 40		↙ 30	
30	3050	G	3040	G	3030	G
35	3550	G	3540	G	3530	G
40	4050	G	4040	G	4030	G
45	4550	G	4540	G	4530	G
50	5050	G	5040	G	5030	G
60	6050	G	6040	G	6030	G
70	7050	G	7040	G	7030	G
80	8050	G	8040	G	8030	G
90	9050	G	9040	G	9030	G
100	10050	G	10040	G	10030	G
120	12050	G	12040	G	12030	G

NOVA XP - CACEROLERO

NOVA XP - PAN DRAWER | NOVA XP - COFFRE

- 1 Laterales H95 Nova XP
- 2 Guías Nova XP ext. total
- 3 Set varilla cuadrada
- 4 Soporte trasera
- 5 Set fijación frontal
- 6 Base y trasera melamina

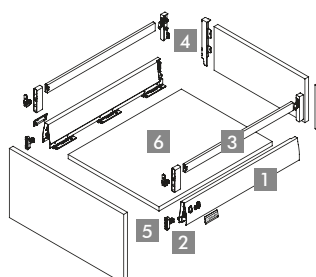
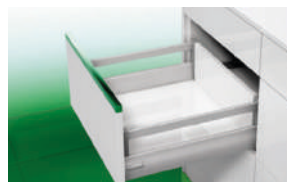

	Cod. 814193					
	↙ 50		↙ 40		↙ 30	
30	3050	G	3040	G	3030	G
35	3550	G	3540	G	3530	G
40	4050	G	4040	G	4030	G
45	4550	G	4540	G	4530	G
50	5050	G	5040	G	5030	G
60	6050	G	6040	G	6030	G
70	7050	G	7040	G	7030	G
80	8050	G	8040	G	8030	G
90	9050	G	9040	G	9030	G
100	10050	G	10040	G	10030	G
120	12050	G	12040	G	12030	G

NOVA XP - CAJÓN INTERIOR

NOVA XP - INNER DRAWER | NOVA XP - TIROIR INTÉRIEUR

- 1 Laterales H95 Nova XP
- 2 Guías Nova XP ext. total
- 3 Ganchos suspensión
- 4 Soporte trasera
- 5 Set fijación frontal
- 6 Base y trasera melamina

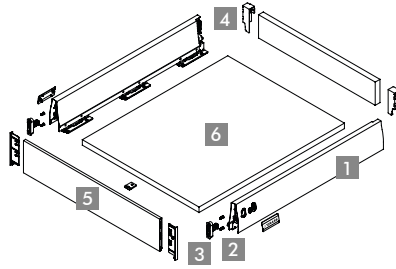
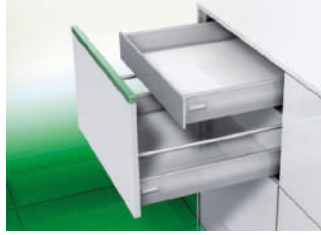

	Cod. 814195					
	↗ 50		↗ 40		↗ 30	
30	3050	G	3040	G	3030	G
35	3550	G	3540	G	3530	G
40	4050	G	4040	G	4030	G
45	4550	G	4540	G	4530	G
50	5050	G	5040	G	5030	G
60	6050	G	6040	G	6030	G
70	7050	G	7040	G	7030	G
80	8050	G	8040	G	8030	G
90	9050	G	9040	G	9030	G
100	10050	G	10040	G	10030	G
120	12050	G	12040	G	12030	G

NOVA XP - CACEROLERO INTERIOR

NOVA XP - INNER PAN DRAWER | NOVA XP - COFFRE INTÉRIEUR

- 1 Laterales H95 Nova XP
- 2 Guías Nova XP ext. total
- 3 Set varilla cuadrada
- 4 Soporte trasera
- 5 Set fijación frontal
- 6 Base y trasera melamina

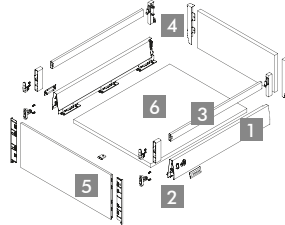

	Cod. 814196					
	↗ 50		↗ 40		↗ 30	
30	3050	G	3040	G	3030	G
35	3550	G	3540	G	3530	G
40	4050	G	4040	G	4030	G
45	4550	G	4540	G	4530	G
50	5050	G	5040	G	5030	G
60	6050	G	6040	G	6030	G
70	7050	G	7040	G	7030	G
80	8050	G	8040	G	8030	G
90	9050	G	9040	G	9030	G
100	10050	G	10040	G	10030	G
120	12050	G	12040	G	12030	G

CAJÓN BAJO HORNO

UNDER OVEN DRAWER | TIROIR BAS FOUR

- 1 Cubeta PVC Inyectado
- 2 Guía extraíble MARC
- 3 Pata altura regulable
- 4 Base fijación con escuadra
- 5 Enganche frontal

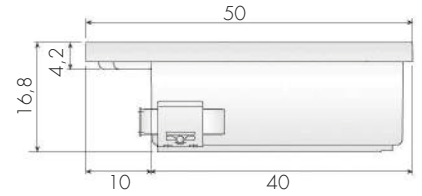

	Cod.
60	812502

CUBERTERO VARIO - SERIE NOVA PRO SCALA / EKALINE

CUTLERY TRAY VARIO - NOVA PRO SCALA / EKALINE SERIES | RANGE COUVERTS VARIO - SERIE NOVA PRO SCALA / EKALINE

Cubertero PVC inyectado, para las Series Nova Pro Scala y Ekaline, en acabado gris. Blanco consultar. La distribución del cubertero cambiará según medida.

PVC injected cutlery tray, for Nova Pro Scala / Ekaline serie, grey finish. Blanco consultar. The distribution of the cutlery tray will change according to measurement.

Couverts injecté PVC pour la série Nova Pro Scala et Ekaline, finition gris. La distribution de range-couverts se modifi selon la mesure.

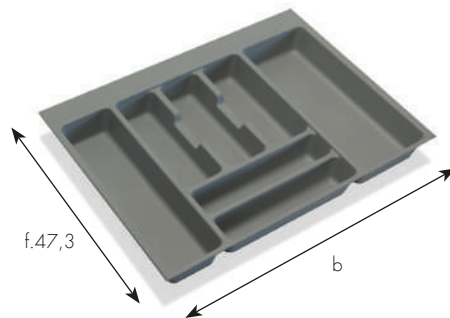

		Cod.	
	b	xxxx	xxxx
30	21,6	30	xx
35	26,6	35	xx
40	31,6	40	xx
45	36,6	45	xx
50	41,6	50	xx
60	51,6	60	xx
70	61,6	70	xx
80	71,6	80	xx
90	81,6	90	xx
100	91,6	100	xx
120	111,6	120	xx

Serie	Cod.
Nova	815302
Ekaline	814231

xx=B Blanco
xx=G Gris
xx=A Antracita

COMPLEMENTOS CUBERTERO VARIO

VARIO CUTLERY ACCESSORIES | ACCESSOIRES DE COUVERTS VARIO

TABLA MADERA
WOODEN TABLE
TABLE EN BOIS



Cod.
81Z114

PORTARROLLOS
INOX/ANTRACITA
ROLL HOLDER
STAINLESS STEEL/ANTHRACITE
PORTE-ROULEAU
ACIER INOXYDABLE/ANTHRACITE



Cod.
81Z11A

PORTACUCHILLOS
MADERA
CARRYING KNIVES WOOD
PORTER DES COUTEAUX BOIS

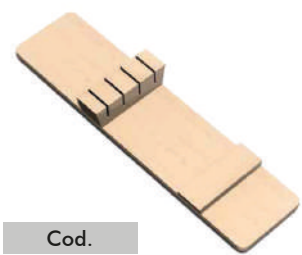

Cod.
81Z110

PORTAPLATOS EXTENSIBLE INTERIOR CACEROLERO

EXTENSIBLE PULLOUT GREY DISH RACK | PORTES-ASSIETTES EXTENSIBLE GRIS

En cada soporte para platos se pueden guardar hasta 12 platos. Base extensible según el diámetro del plato, desde 45 cm a 65 cm.

In each bracket for dishes you can save up to 12 dishes. Extensible base according to the diameter of the dish, from 45 cm to 65 cm.

Sur chacun des portes assiettes permet ranger jusqu'à 12 assiettes. Base extensible en fonction du diamètre de l'assiette.

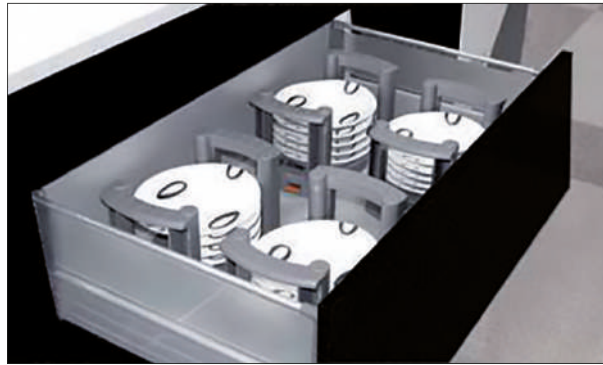

Cod.
81Z181

FONDO PERFORADO MADERA

DRILLED BOTTOM PANEL | FOND PERFORÉ

Fondo perforado de MDF color haya, de un 1 cm de grosor y 47,1 cms de profundidad. Con soportes para adaptar a la medida de la vajilla.

1 cm. beech MDF perforated bottom and 47,1 cm deep. With supports to adapt to suit the dishes.

Fonds perforée MDF couleur hêtre a un 1 cm d'épaisseur et 47,1 cm de profondeur. Avec supports pour adapter à la vaisselle.

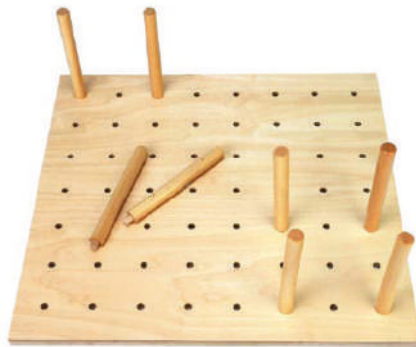

SOPORTE FONDO PERFORADO
STICKS FOR DRILLEND BOTTOM PANEL SET
SOUTENIR FOND PERFORÉ

Cod.
81Z151

	Cod.
	81Z150
60	60
70	70
80	80
90	90
100	100
120	120

FONDO PERFORADO MADERA BLANCO

WHITE DRILLED BOTTOM PANEL | FOND PERFORÉ BOIS BLANC

Fondo perforado de MDF color blanco, de un 1 cm de grosor y 47,1 cms de profundidad. Con soportes para adaptar a la medida de la vajilla.

1 cm. white MDF perforated bottom and 47,1 cm deep. With supports to adapt to suit the dishes.

Fonds perforée MDF couleur blanc a un 1 cm d'épaisseur et 47,1 cm de profondeur. Avec supports pour adapter à la vaisselle.

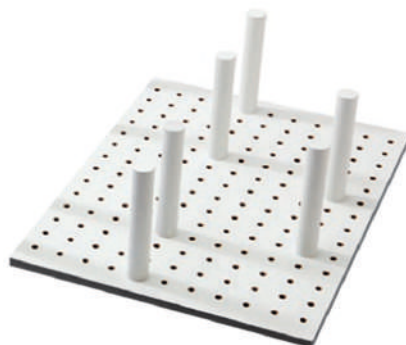

SOPORTE FONDO PERFORADO
STICKS FOR DRILLEND BOTTOM PANEL SET
SOUTENIR FOND PERFORÉ

Cod.
81Z153

	Cod.
	81Z152
60	60
70	70
80	80
90	90
100	100
120	120

COMPLEMENTOS PARA CAJÓN / CACEROLERO MADERA DELUXE

ACCESSORIES FOR DRAWER / PAN DRAWER WOOD DELUXE | COMPLEMENTS POUR TIROIRS / CASSEROLIER EN BOIS DELUXE

Complementos para cajón / cacerolero, realizado en tablero fenólico de 1 cm de grosor, rechapado en haya.

Para series Nova Pro Scala y Ekaline, especificar al realizar el pedido.

Accessories for drawer / pan drawer, made in phenolic board of 1 cm. Thick, Veneered in beech. for Nova Pro Scala and Ekaline series, specify when ordering.

Effectué en planche phénolique de 1 cm d'épaisseur fait en plançage d'hêtre pour series Nova Pro Scala et Ekaline. Préciser à la commande.



 **Cod.**
30 81Z101 - 30



 **Cod.**
35 81Z101 - 35



 **Cod.**
40 81Z101 - 40



 **Cod.**
45 81Z101 - 45



 **Cod.**
50 81Z101 - 50



 **Cod.**
60 81Z101 - 60



 **Cod.**
90 81Z101 - 90



 **Cod.**
120 81Z101 - 120

COMPLEMENTOS PARA CAJÓN / CACEROLERO MADERA DELUXE

ACCESSORIES FOR DRAWER / PAN DRAWER WOOD DELUXE | COMPLEMENTS POUR TIROIR / CASSEROLIER BOIS DELUXE

CAJÓN MADERA DELUXE / DELUXE WOODEN DRAWER / TIROIR DE LUXE EN BOIS

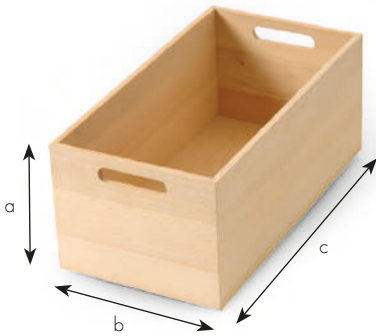

a†	b	c	Cod.
19	20	23	81Z131-P20
19	24	23	81Z131-P24
19	30	23	81Z131-P30
19	24	46	81Z131-P24

CAJÓN MADERA DELUXE BOTELLERO / DELUXE WOODEN DRAWER BOTTLE RACK / PORTE-BOUTEILLES DE LUXE EN TIROIR EN BOIS

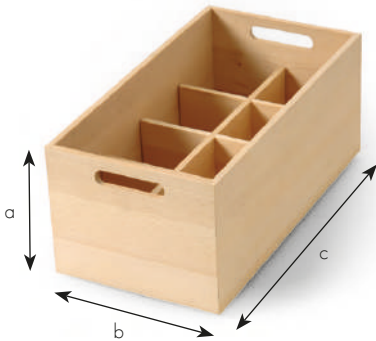

a†	b	c	Cod.
19	24	23	81Z132-P24
19	24	46	81Z132-G24

COMPOSICIONES / COMPOSITIONS / COMPOSITIONS

600 MM

2 cajas de 240 x 230
1 caja de 240 x 460

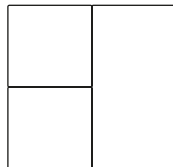

600 MM

2 cajas de 240 x 460

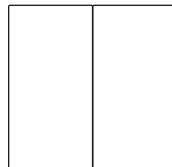

600 MM

4 cajas de 240 x 230

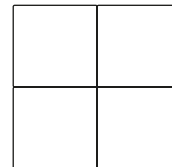

800 MM

Composición de 600 mm
2 cajas de 200 x 230

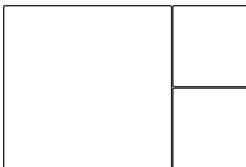

900 MM

Composición de 600 mm
2 cajas de 300 x 230

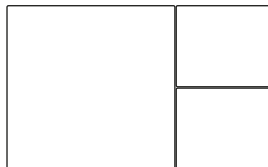

1000 MM

Composición de 600 mm
4 cajas de 200 x 230

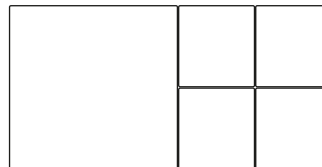

1200 MM

Composición de 600 mm
4 cajas de 300 x 230

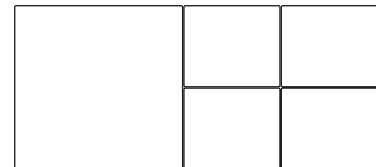

PORTAESPECIAS (4 TARROS) MADERA DELUXE

SPICE RACK (4 BOWL) WOOD DELUXE | ÉTAGÈRES À ÉPICES (4BOLS) EN BOIS DELUXE

Portaespecias con botes en inox.
Stainless steel boat holders.
Portaespecias bateau inoxydable.



Para ancho	Cod.
60-90-120	81Z116

ESCURREPLATOS / DISH DRAINER / ÉGOUTTOIR



CARACTERÍSTICAS GENERALES i

Los conjuntos de escurreplatos extra en acero inoxidable, con una amplia gama de medidas, se ajusta perfectamente a las necesidades de modulación en la cocina.

Extra sets of stainless steel drainer with a wide range of sizes, fits perfectly with the modulation needs in the kitchen.

Ensembles supplémentaires d'égouttoir en acier inoxydable avec une large gamme de tailles, s'adapte parfaitement à l' modulation doit dans la cuisine.

JUEGO ESCURREPLATOS EXTRA INOX-INOX

EXTRA STEEL PLATE RACK | EGOUTTOIR EXTRA INOX-INOX

Juego escurreplatos extra Inox-Inox, incluye bandeja inox recoge-aguas.

Steel drainage tray included.

Comprend un plateau en acier recueille eau.

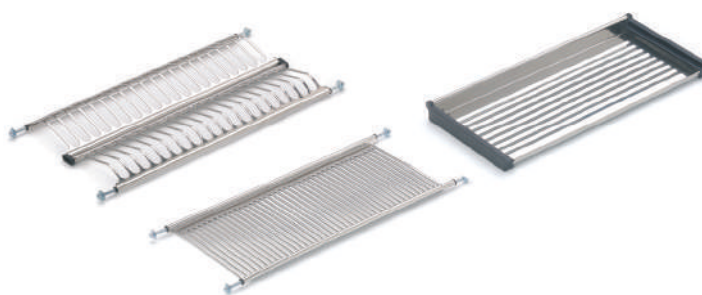

	Cod.
\overleftarrow{b}	824001
45	45
50	50
60	60
70	70
80	80
90	90
100	100

BISAGRAS | HINGES | CHARNIÈRES

SIST. DE APERTURA | OPENING SYS. | SYSTÈMES D'OVERTURE



SERIE BLUM BLUMOTION

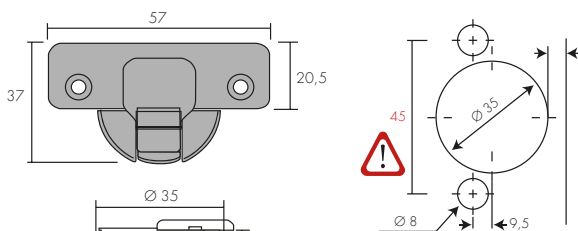

- Con tetón / With dowel / Avec cheville
- Sin tetón / Without dowel / Sans cheville

CARACTERÍSTICAS GENERALES i

Bisagra metálica niquelada.
Puertas de espesor mín. 16 mm.
Regulación Lateral ± 2 mm.
Vertical ± 3 mm.
Frontal con base de -2 a +3 mm.

Nicker metal hinge.
Door thickness min. 16 mm.
Side adjustment ± 2 mm.
Vertical adjustment ± 3 mm.
Based frontal -2 to +3 mm.

Charnière en acier nickelé mat.
Portes d'épaisseur min. 16mm.
Regulation latéral ± 2 mm.
vertical ± 3 mm.
frontal avec base -2 a +3 mm.

RECTA 110°

STRAIGHT 110° | SILENTIA DROITE

110°



Cod.

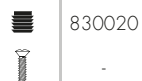

CLIP

RINCÓN 180°

CORNER 180° | SILENTIA COIN 180°

165°



Cod.



CLIP

RINCÓN CIEGO

CORNER CHAMFER | SILENTIA COIN D'ANGLE

94°



Cod.



CLIP

RECTA 110° ONIX

STRAIGHT 110° | DROITE 110°

110°



Cod.



CLIP

RINCÓN 180° ONIX

CORNER 180° ONIX | COIN 180° ONIX

165°

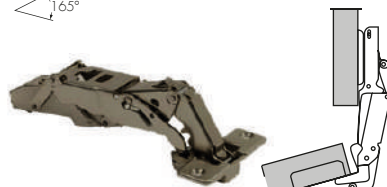

Cod.

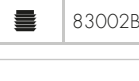

CLIP

RINCÓN CIEGO ONIX

CORNER CHAMFER ONIX | COIN D'ANGLE ONIX

94°



Cod.

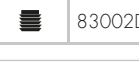

CLIP

BASE

BASE | BASE



Cod.



BASE ONIX

BASE ONIX | BASE ONIX

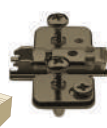

Cod.



BASE RECTA

STRAIGHT BASE | BASE DROITE

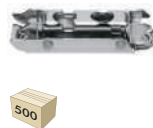

Cod.

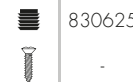

BASE RECTA ONIX

STRAIGHT BASE ONIX | BASE DROITE ONIX

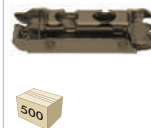

Cod.

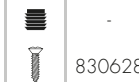

TAPA PALA BISAGRA

HINGE FLAP COVER
COUVERCLE PALE CHARNIÈRE



Cod.

830926

TAPA PALA BISAGRA ONIX

HINGE FLAP COVER ONIX
COUVERCLE PALE CHARNIÈRE ONIX



Cod.

830928

TAPA CAZOLETA BISAGRA

HINGE CONCEALED COVER
COUVERCLE SUPPORT CHARNIÈRE



Cod.

830927

TAPA CAZOLETA BISAGRA ONIX

HINGE CONCEALED COVER ONIX
COUVERCLE SUPPORT CHARNIÈRE ONIX



Cod.

830929

SERIE SALICE SILENTIA

SALICE

CARACTERISTICAS GENERALES 

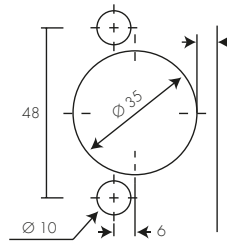
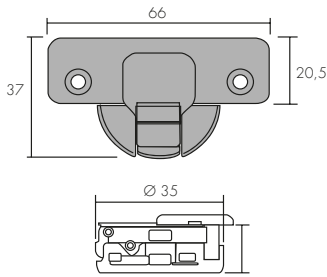

13,5



	Con tetón With dowel / Avec cheville
	Sin tetón Without dowel / Sans cheville

Bisagra de acero niquelado opaco.
Puertas de espesor mín. 16 mm.
Regulación lateral -1,5 a +4,5 mm.
Vertical +2 mm.
Frontal con base +2,8 mm.

Opaque nicker plated steel hinge.
Door thickness min. 16 mm.
Side adjustment -1,5 to +4,5 mm.
Vertical adjustment +2 mm.
Based frontal +2,8 mm.

Charnière en acier nickelé mat.
Portes d'épaisseur min. 16mm.
Regulation latéral -1,5 a +4,5 mm.
vertical +2 mm.
frontal avec base +2,8 mm.

SILENTIA RECTA 110°

SILENTIA STRAIGHT 110° | SILENTIA DROITE 110°



Cod.

	830010
	-



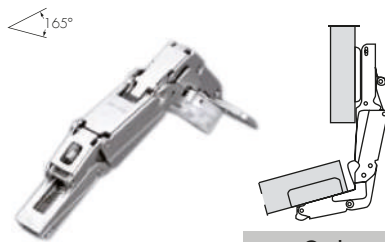

SILENTIA RINCÓN 180°

SILENTIA CORNER 180° | SILENTIA COIN 180°



Cod.

	830011
	-



SILENTIA RINCÓN CIEGO

SILENTIA BLIND CORNER | SILENTIA COIN AVEUGLE



Cod.

	830013
	-



BASE CLIP

BASE CLIP | BASE CLIP



Cod.

	830605
	-





BASE INCLINABLE GRUESA

THICK TILTBASE | BASE INCLINAISON ÉPAIS



Cod.

	-
	830703





BASE INCLINABLE PLANA

FLAT TILTBASE | BASE INCLINAISON PLAT



Cod.

	-
	830704



BASE ALTURA 0

BASE HEIGHT 0 | BASE HAUTEUR 0



Cod.

	-
	830705



NEW

BISAGRA RINCOMATIC PLUS INOX

RINCOMATIC PLUS INOX HINGE | CHARNIÈRE RINCOMATIC PLUS ACIER

Bisagra Rincomatic Plus inox, unión doble puerta, para rincón angular. Consultar medidas especiales. Con tres nudos a partir de 90 cm.



Rincomatic Plus inox hinge, double door joint for "L" shaped corner cabinet. Ask for special measures. With three joints from 90 cm.

Charnière Rincomatic Plus acier, union double porte pour coin angulaire. Consulter mesures spéciales avec trois ensembles à partir de 90 cm.

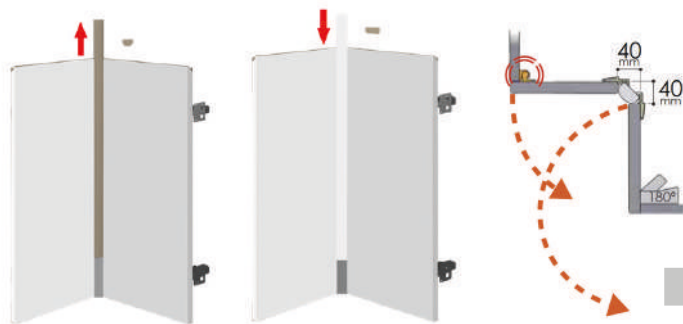

		Cod.
α†		831001
70	70	I
90	90	I

TACARINCÓN - RINCONBASIC

STRIP CORNER - RINCONBASIC | BANDE D'ANGLE RINCONBASIC

La regla de rincón Rincomatic Basic permite el acceso al rincón mediante puertas independientes.

The strip Rincomatic Basic allows access to the corner by independent doors.

La bande d'angle Rincomatic Basic permet l'accès grâce aux portes indépendantes.

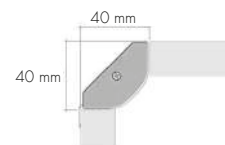
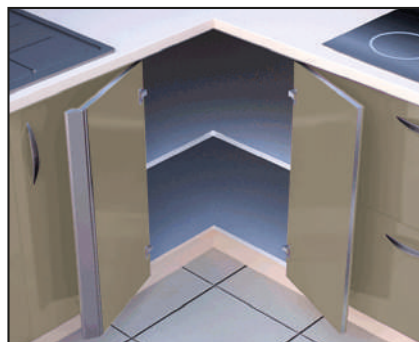

		Cod.
α†		831011
xx=A Mate	70	70 xx
xx=B Blanco	90	90 xx
xx=N Negro		

BLUM - SISTEMA APERTURA AVENTOS HF

BLUM - AVENTOS HF OPENING SYSTEM | BLUM - SYSTÈME D'OVERTURE AVENTOS HF

Sistema apertura plegable Aventos HF. Dependiendo de la medida del mueble se elegirá la opción de los Kgs más conveniente.
Consultar sistema Aventos HF eléctrico. 

Opening folding system Aventos HF depending on the cabinet measurement, will choose the best option in order to the Kgs.
Ask for electronic system Aventos HF.

Système d'ouverture Aventos HF selon mesure du meuble choisin l'option de Kg la plus pratique. Consulter système Aventos HF électrique.

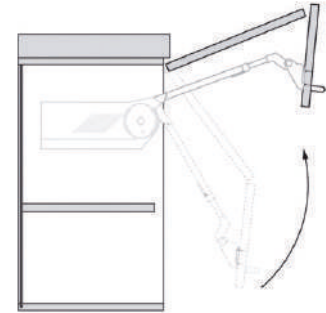

Cod. 833101

a	b					
	60	70	80	90	100	120
70	K22	K22	K22	K22	K25	K25
80	K22	K25	K25	K25	K25	K28
90	K25	K25	K28	K28	K28	K28

BLUM - SISTEMA APERTURA AVENTOS HS

BLUM - AVENTOS HS OPENING SYSTEM | BLUM - SYSTÈME D'OVERTURE AVENTOS HS

Sistema apertura puerta oblicuo Aventos HS.
Consultar sistema Aventos HS eléctrico. 

Angled door opening Aventos HS system.
Ask for electronic stay Aventos HS system.

Système d'ouverture porte oblique Aventos HS.
Consulter système Aventos HS électrique.

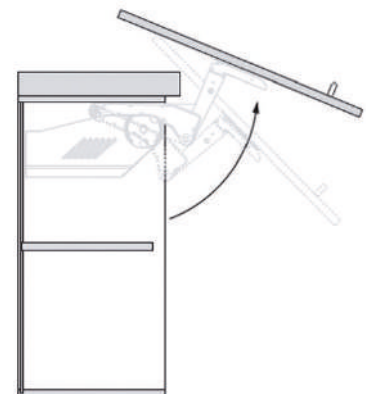

Cod. 833131

a	b					
	60	70	80	90	100	120
40	A	A	A	B	B	B
45	A	A	B	B	B	B
50	A	B	B	B	B	C
60	D	D	E	E	E	E
70	G	G	H	H	H	H
80	G	H	H	H	H	I

BLUM - SISTEMAS DE APERTURA AVENTOS HL

BLUM - AVENTOS HL OPENING SYSTEM | BLUM - SYSTÈME D'OUVERTURE AVENTOS HL

Sistema apertura puerta vertical Aventus HL. Consultar sistema Aventus HL eléctrico. 

Angled door opening Aventus HL system. Ask for electronic stay Aventus HL system.

Système d'ouverture porte vertical Aventus HL. Consulter système Aventus HL électrique.

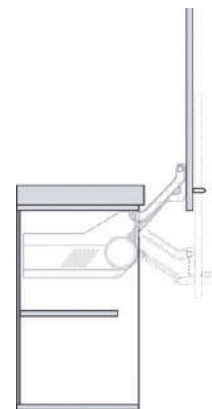

Cod. 833141

a†	b					
	60	70	80	90	100	120
35	L32L21	L32L21	L32L21	L32L21	L32L23	L32L23
40	L35L25	L35L25	L35L25	L35L25	L35L25	L35L25
45	L38L25	L38L25	L38L25	L38L25	L38L25	L38L27
60	L39L25	L39L27	L39L27	L39L27	L39L27	L39L29

BLUM - SISTEMA DE APERTURA AVENTOS HK

BLUM - AVENTOS HK OPENING SYSTEM | BLUM - SYSTÈME D'OUVERTURE AVENTOS HK

Sistema apertura abatible Aventus HK. Consultar sistema Aventus HK eléctrico. 

Opening folding Aventus HK system. Ask for electronic stay Aventus HK system.

Système d'ouverture à vasistas Aventus HK. Consulter système Aventus HK électrique.

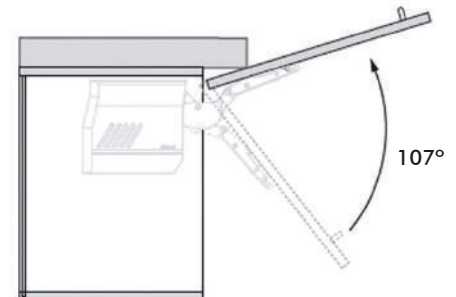

Disponibles limitadores de apertura de 100° y 75°
Available restrictors opening 100° and 75°
Restricteurs disponibles ouverture de 100° et 75°



Cod. 833151

a†	b					
	60	70	80	90	100	120
28	K23	K23	K23	K23	K25	K25
35	K23	K23	K25	K25	K25	K25
40	K25	K25	K25	K25	K27	K27
45	K25	K25	K25	K27	K27	K27
50	K25	K27	K27	K27	K27	K27
60	K27	K27	K27	K27	K29	K29

BLUM - SISTEMA DE APERTURA AVENTOS HK-S

BLUM - AVENTOS HK-S OPENING SYSTEM | BLUM - SYSTÈME D'OVERTURE AVENTOS HK-S

Sistema apertura abatible Aventos HK-S
Máximo para mueble de altura 40.

Aventos HK-s opening folding system.
Maximum for 40 cm. cabinet height.

Système d'ouverture à vasistas Aventos
HK-S maximum pour meuble de 40
d'hauteur.

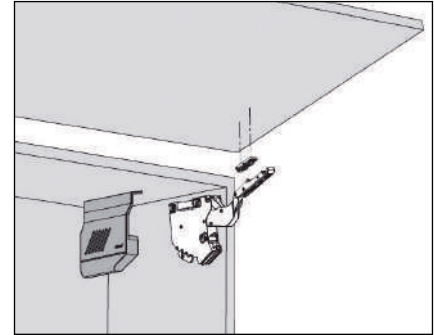

Disponibles limitadores de apertura de 100° y 75°
Available restrictors opening 100° and 75°
Restricteurs disponibles ouverture de 100° et 75°



Cod. 833161						
a†	b					
	45	50	60	70	80	90
28	CC	CC	CC	CE	CE	CE
35	CC	CE	CE	CE	CE	EE
40	CE	CE	EE	EE	EE	EE

BLUM - SISTEMA DE APERTURA AVENTOS HK PUSH TIP-ON

BLUM - AVENTOS HK TIP-ON OPENING SYSTEM | BLUM - SYSTÈME D'OVERTURE AVENTOS HF TIP-ON

Sistema apertura abatible Aventos HK
Tip-on, con pulsador.

Opening folding Aventos HK Tip-on
system with push button.

Système d'ouverture à vasistas Aventos
HK Tip-on, avec bouton poussoir.

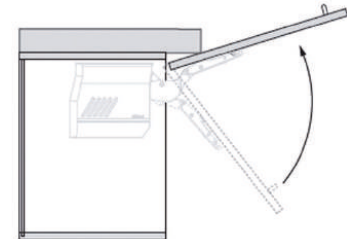

107°

Disponibles limitadores de apertura de 100° y 75°
Available restrictors opening 100° and 75°
Restricteurs disponibles ouverture de 100° et 75°



Incluye pulsador Tip-on corto y soporte.
Includes push-on Tip short and support.
Comprend push-court sur la pointe et de soutien.



Cod. 833151						
a†	b					
	60	70	80	90	100	120
28	K23P	K23P	K23P	K23P	K25P	K25P
35	K23P	K23P	K25P	K25P	K25P	K25P
40	K25P	K25P	K25P	K25P	K27P	K27P
45	K25P	K25P	K25P	K27P	K27P	K27P
50	K25P	K27P	K27P	K27P	K27P	K27P
60	K27P	K27P	K27P	K27P	K29P	K29P

PEGASO SISTEMA DE APERTURA LATERAL

OPENIG SYSTEM PEGASO | SYSTÈME D'OVERTURE PEGASO

Sistema apertura lateral Pegaso, con freno.

Side opening system Pegaso with brake.

Système d'ouverture latérale Pegaso, avec freinage.



	Cod.
	834001
40	40
45	45
60	60
65	65

M2200 SISTEMA PLEGABLE DESLIZANTE LATERAL

M2200 SIDE FOLDING DOORS OPENIN SYSTEM | SYSTÈME D'OVERTURE PORTES PLIANTES M2200

Sistema apertura puertas plegables lateral, tipo libro.

Consultar según medidas.

Side folding doors opening system book type.

Ask for measurement.

Système d'ouverture portes pliantes, de type livre. Consulter selon mesures.

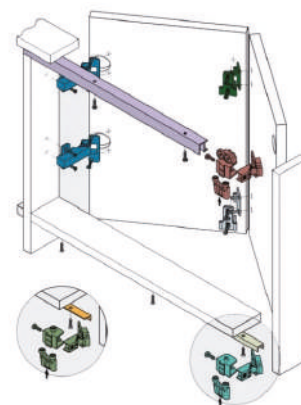

Cod.
834011

SISTEMA COPLANAR 2 PUERTAS

COPLANAR SYSTEM 2 DOORS | SYSTÈME COPLANAR 2 PORTES

Sistema de puertas deslizantes coplanar con sistema de amortiguación.

System of sliding doors coplanar with system of damping.

Système portes coulissantes coplanaire avec système d'amortissement.



	Cod.
	834111

H. HASTA 720
H. HASTA 1220
H. HASTA 2000

SISTEMA ESCAMOTEABLE SALICE EXEDRA

RETRACTABLE SYSTEM SALICE EXEDRA | SYSTÈME ESCAMOTABLE SALICE EXEDRA

Sistema para puertas escamoteables con movimiento de retorno lateral asistido y amortiguado y movimiento de salida regulado por un dispositivo de seguridad.

System for retractable doors with side return movement assisted and damped and exit movement regulated by a safety device.

Système pour portes escamotables avec mouvement de retour latéral assisté, amortissement, et mouvement externe régulé par un dispositif de sécurité.

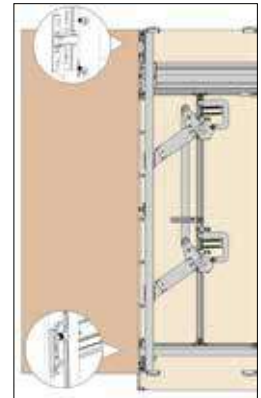

Espesor | Thickness | Épaisseur: 18-30 mm
Anchura | Width | Largeur: 400-900 mm
Altura | Height | Hauteur: 1333-2530 mm
Movimiento amortiguado en apertura y en retorno | Cushioned movement in opening and return
Mouvement amorti en ouverture et retour

Cod.
834321-S

SISTEMA ESCAMOTEABLE SALICE EXEDRA2 STAR

RETRACTABLE SYSTEM SALICE EXEDRA2 STAR | SYSTÈME ESCAMOTABLE SALICE EXEDRA2 STAR

Evolución del sistema Exedra, que permite gestionar dos puertas al mismo tiempo. Con retorno y salida asistidos y controlados por un dispositivo magnético.

Evolution of the Exedra system, which allows managing two doors at the same time. With return and exit assisted and controlled by a magnetic device.

Evolution du système Exedra, qui permet de gérer deux portes en même temps. Avec retour et sortie assistés et contrôlés par un dispositif magnétique.

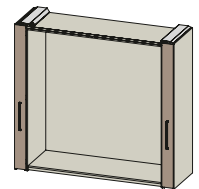
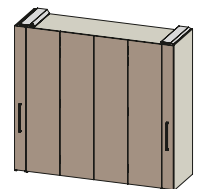

Espesor | Thickness | Épaisseur: 18-25 mm
Anchura | Width | Largeur: 450-750 mm
Altura | Height | Hauteur: 1800-2600 mm
Movimiento amortiguado en apertura y en retorno | Cushioned movement in opening and return
Mouvement amorti en ouverture et retour

Cod.
834331



HERRAJES VARIOS | SEVERAL HARDWARE | MATÉRIEL DIVERS



JUEGO COLGADOR MUEBLE RAPID + PLACA DOBLE

CABINET HIDDEN HANGER RAPID + DOUBLE FIXING PLATE SET | JEU SUSPENSION RAPID + DOUBLE CACHÉE

Juego de colgador oculto regulable desde el interior del mueble con placa fijación pared doble.

Set hidden hanger adjustable from inside the cabinet with double wall fixing plate.

Ensemble cintre caché réglable de l'intérieur du coffret avec plaque de fixation à double paroi.

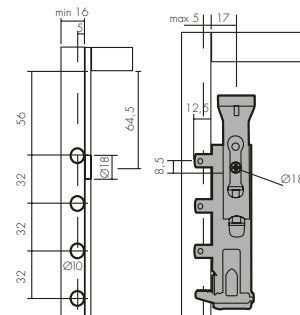

Cod.
841000

PINZA DE ZÓCALO PVC ALUMINIO

PLUS ENCHANCED LEG | CLIP SOCLE PVC ALUMINIUM

Pinza para zócalo de PVC aluminio.

Enchanced leg for PVC aluminium.

Clip pour socle de PVC aluminium.



Cod.
841006

PERFIL PROTECTOR ZÓCALO TRANSPARENTE

TRANSPARENT PROTECTED PROFILE FOR PLINTH | PROFIL DE PROTECTION SOCLE TRANSPARENT

Perfil antihumedad protector de zócalo madera. Grosor de 1,6 y 2,2 cms.

Moisture protected profile for wood plinth 1,6 and 2,2 cm thick.

Profil d'humidité de protection pour socle bois, épaisseur de 1,6 et 2,1 cm.

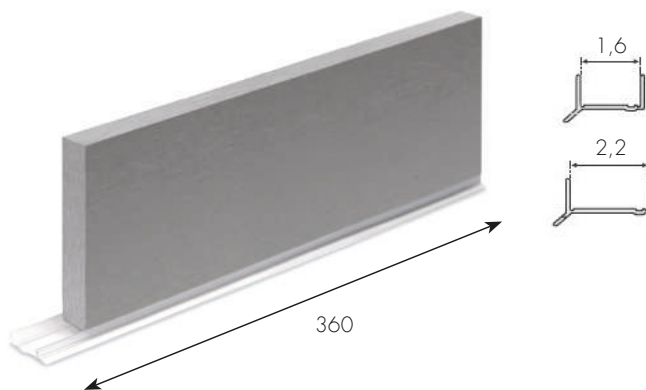

Cod.

Perfil 1,6 841003
Perfil 2,2 841005

PATA REGULABLE PLUS REFORZADA

PLUS ENCHANCED LEG | PIED RÉGLABLE RENFORCÉE PLUS

Pata reforzada plus regulable en altura de 10 a 13 y de 13 a 19 cms, con base empotrable con tetón de 13 mm.

Plus leg enchanced, height adjustable from 10 to 13 cm and from 13 to 19 cm with 13 mm integrated base with dowel.

Pied renforcée plus réglable en hauteur de 10 a 13 cm et de 13 a 19 cm, base intégré avec teton de 13 mm.



Cod.

Pata de 13-19 840011

Pata de 10-13 840012

PATA DECORATIVA PVC ALUMINIO REDONDA 15

ROUND ALUMINIUM DECORATIVE LEG | PIED DÉCORATIF COULEUR ALUMINIUM ARRONDI 15

Pata pvc color aluminio redonda con regulación en altura 14 a 16 cms.

PVC round aluminium decorative leg with height adjustable from 14 to 16 cms.

Pied PVC couleur aluminium arrondi avec régulation en hauteur 14 a 16 cms.

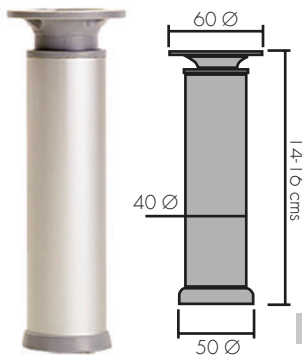

Cod.
842010

PATA DECORATIVA PVC ALUMINIO CUADRADA 15

SQUARE DECORATIVE LEG ALUMINIUM COLOR 15 | PIED DÉCORATIF PVC COULEUR ALUMINIUM CARRÉ 15

Pata pvc color aluminio cuadrada con regulación en altura 15 a 17,5 cms.

PVC square aluminium decorative leg with height adjustable from 14 to 16 cms.

Pied PVC couleur aluminium carré avec régulation en hauteur 15 a 17,5 cms.

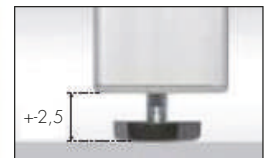
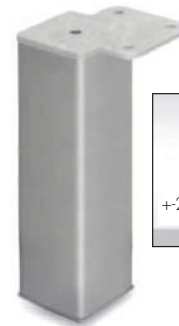

Cod.
842015

PIE MOSTRADOR METÁLICO

METALIC BAR COUNTER LEG | PIED DE COMPTOIR EN MÉTAL

Pie mostrador metálico de 6 cm de diámetro en 4 acabados.

Metalic bar counter leg, 6 cm diameter with 4 finishes.

Pied de compteur en métal de 6 cm de diamètre.



α		Cod.
83-86	Blanco White Blanc	842111
83-86	Negro Black Noir	842112
83-86	Cromo brillo Shining chrome Chrome brillant	842113
83-86	Cromo mate Matt. chrome Chrome Mat.	842114

ESTRUCTURA DE APOYO 6010

SUPPORT STRUCTURE 6010 | STRUCTURE DE SUPPORT 6010

Estructura modular para penínsulas y muebles en diferentes medidas y colores.

Modular structure for peninsulas and furniture in different sizes and colors.

Structure modulaire pour péninsules et meubles de différentes tailles et couleurs.



α		Cod.
60-90-120	Blanco White Blanc	842511
60-90-120	Negro Black Noir	842511
60-90-120	Cromo brillo Shining chrome Chrome brillant	842511
60-90-120	Cromo mate Matt chrome Chrome mat	842511

COPETE MIXTO RECTO

UPSTAND | ALÈSE MIXTE DROITE

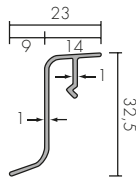

Artículo Article Article			b		Cod.
Copete	Upstand	Alèse	4 mts		845001 - C
Esquina copete	External corner	Coin extérieur d'alèse			845101 - C
Rincón copete	Inner corner	Coin intérieur d'alèse			845201 - C
Jg. Terminal copete	End caps	Jeu terminal d'alèse			845301 - C

COPETE MIXTO BISEL

UPSTAND | ALÈSE MIXTE BISEL

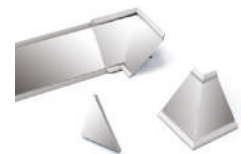
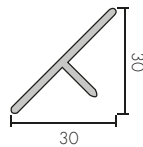
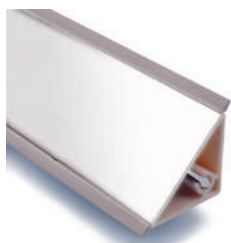

Artículo Article Article			b			Cod.
Copete	Upstand	Alèse	4 mts			845051 - xx
Esquina copete	External corner	Coin extérieur d'alèse				845151 - xx
Rincón copete	Inner corner	Coin intérieur d'alèse				845251 - xx
Jg. Terminal copete	End caps	Jeu terminal d'alèse				845351 - xx

UNIÓN ENCIMERA RECTA

WORKTOP JOINING STRIP | UNION DROITE DE BANDE DE PLAN DE TRAVAIL

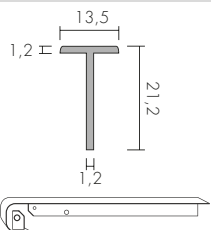

R - I		Cod.
		845501
R06 - 30MM		R0630 - C
R04 - 30MM		R0430 - C
R04 - 38MM		R0440 - C

UNIÓN ENCIMERA ÁNGULO

WORKTOP DOUBLE JOINING STRIP | UNION ANGULAIRE DE BANDE DE PLAN DE TRAVAIL

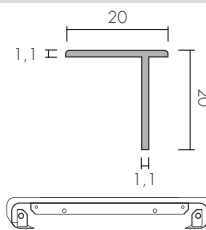

R - I		Cod.
		845601
R06 - 30MM		R0630 - C
R04 - 30MM		R0430 - C
R04 - 38MM		R0440 - C

REMATE ENCIMERA

WORKTOP END | CANTONIERE DE PLAN DE TRAVAIL

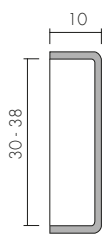
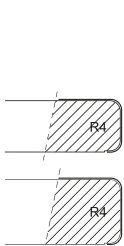

R - I		Cod.
		845401
R04 - 30MM		R0430 - C
R04 - 38MM		R0440 - C

HERRAJE UNIÓN ENCIMERA

WORKTOP JOINING FITTING | FERRAJE JONCTION PLAN DE TRAVAIL

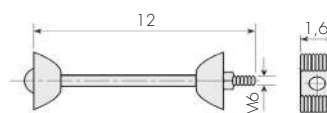

Cod.
845701

NEW

REJILLA HORNO

METAL OVEN RACK | GRILLE FOUR

Rejilla de horno metálica, altura 8 cms en 3 acabados diferentes.

Metal oven rack, 8 cms height and 3 different finishes.

Grille du four en métal hauteur 8 cms et 3 terminaisons différents.

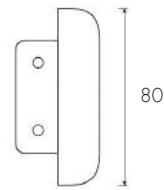

	Cod.
Blanco White Blanc	846021
Negro Black Noir	846022
Inox Inox Inox	846023

REJILLA FRIGORIFICO

FRIDGE VENTILATION RACK | GRILLE RÉFRIGÉRATEUR

Rejilla aireación frigorífico, 8 lamas. Ajustable en altura.

Fridge ventilation rack eight slats. Height adjustable.

Grille d'aération de réfrigérateur. 8 lattes. Réglable en hauteur

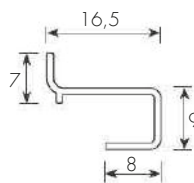

b		Cod.
60	Blanco White Blanc	846001
60	Negro Black Noir	846002
60	Inox Inox Inox	846003
90	Inox Inox Inox	846014

REJILLA AIREACIÓN PARA ZÓCALO

INTEGRATED PLINTH RACK | GRILLE RÉFRIGÉRATEUR INTÉGRÉ SOCLE

Rejilla de integración en zócalo, para la ventilación del frigo.

Integrated plinth rack for fridge ventilation.

Grille d'intégratin dans socle pour aération de réfrigérateur.

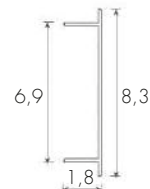
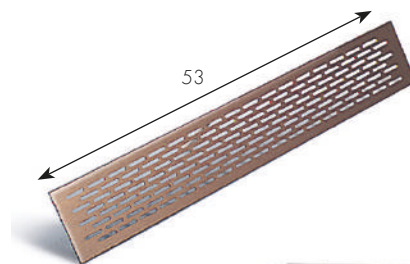

	Cod.
Blanco White Blanc	846031
Negro Black Noir	846032
Inox Inox Inox	846033

MARCO MICROONDAS INYECTADO

ABS MICROWAVE FRAME | CADRE INSECTER MICROONDE

Marco microondas inyectado. Medidas exteriores 40x60. Cortable según modelo microondas.

Microwave frame PVC injectec. External measures 40x60. Cuttable as microwave model.

Cadre injecter microonde mesures extérieur 40x60. Découpable comme modèle de microondes



	Cod.
	846101
Cromo Chrome Chrome	C
Blanco White Blanc	B
Negro Black Noir	N

HERRAJE PERSIANILLA PVC ALUMINIO

PVC ALUMINIUM SHUTTER SET | FERRAGE RIDAU PVC ALUMINIUM

Persiana de estructura y lamas en material de PVC Aluminio.

Shutter with PVC Aluminium slats structure.

Ridau de structure et lattes en PVC Aluminium.

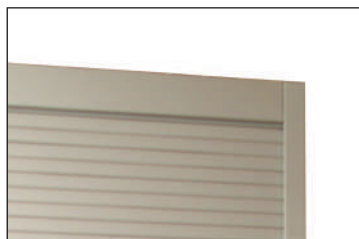

		Cod.	
a†	b_	847001	
130	60	13060	AL
150	60	15060	AL
150	90	15090	AL

HERRAJE PERSIANILLA PVC COLORES

PVC COLORS SHUTTER SET | FERRAGE RIDAU PVC COULEURS

Persiana de estructura y lamas en material de PVC en diferentes colores.

Shutter with PVC different colours slats structure.

Rideau de structure et lattes en PVC différentes couleurs.



- xx = AL (Aluminio)
- xx = CA (Carbono)
- xx = BL (Blanco)
- xx = PI (Pizarra)
- xx = NG (Negro)
- xx = BA (Basalto)
- xx = SBL (S-Mat Blanco Roto)
- xx = SGC (S-Mat Gris Claro)
- xx = SVE (S-Mat Verde)
- xx = STU (S-Mat Turquesa)
- xx = SAZ (S-Mat Azul Oscuro)
- xx = SRJ (S-Mat Rojo)
- xx = TI (Titanio)

		Cod.	
a†	b_	847001	
130	60	13060	xx
130	90	13090	xx
150	60	15060	xx
150	90	15090	xx

HERRAJE PERSIANILLA ALUMINIO

ALUMINIUM SHUTTER SET | FERRAGE RIDAU ALUMINIUM

Persiana de estructura y lamas en material de 100% Aluminio.

Shuter with 100% Aluminium slats structure.

Ridau de structure et lattes en 100% Aluminium.



		Cod.	
a†	b_	847002	
90	60	9060	AL
150	45	15045	AL
150	60	15060	AL
150	80	15080	AL
150	90	15090	AL

HERRAJE PERSIANA CRISTAL

GLASS SHUTTER SET | FERRAGE RIDAU CRISTAL

Elegante persiana cristal de lamas de 5 cm, con cristal de seguridad, en tres acabados.

Elegant shutter glass of slats of 5 cm whit safety glass, in three finishes.

Elégant ridau de lattes en verre de séguité en trois terminaisons.

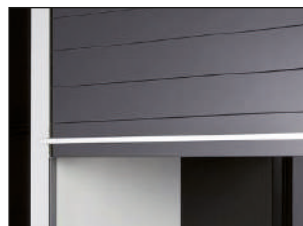

- xx = B (Blanco | White | Blanc)
- xx = N (Negro | Black | Noir)
- xx = S (Satinado | Satin | Satin)

		Cod.	
a†	b_	847004	
150	60	15060	xx
150	90	15090	xx

BARRA SOPORTE ENCIMERA GRANITO C/TETÓN

REINFORCED BAR FOR GRANITE COUNTERTOP | BARRE DE SUPPORT DU COMPTOIR DE GRANIT C/TETON

Barra de refuerzo para encimera de granito, para integrar en mueble fregadero o placa.

Reinforced bar for granite countertop, to integrate or plate sink cabinet.

Rebar comptoir de granit, à intégrer ou une plaque meuble évier.

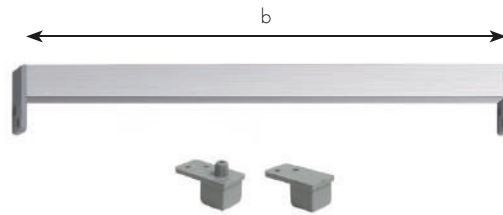

		Cod.
		848004
60	56,8	60
70	66,8	70
80	76,8	80
90	86,8	90
100	96,8	100
120	116,8	120

ESCUADRA MESA ABATIBLE

SQUARE FOLDING TABLE | SUPPORT ANGLE TABLE PLIANTE

Escuadra mesa abatible, acabado cromo, en 2 medidas.

Bracket for folding table chrome finish.

Support angle pour table pliante finition chrome.

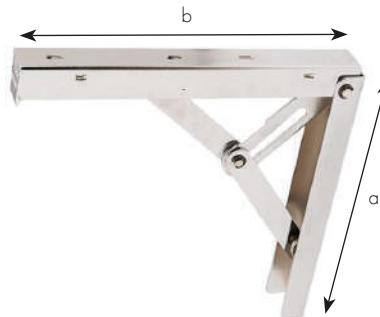

$a \downarrow$	$b \rightarrow$	Cod.
30	30	848101
40	40	842102

SOPORTE ESTANTE/GALERÍA OCULTO

HIDE SHELF SUPPORT | APPUI GALERIE CACHÉ

Soporte estante/galería oculto, con taco fijación pared.

Hide shelf support with dowel for wall fixing.

Support galerie / étagère caché, avec taquet fixation mur.

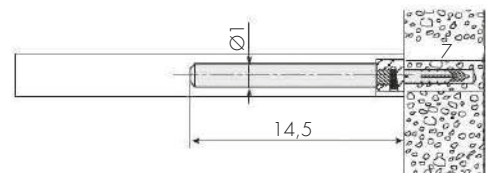

Cod.
848311

BARRA SOPORTE ESTANTE ALUMINIO

ALUMINIUM BAR FOR SHELF SUPPORT | BARRE SUPPORT ÉTAGÈRE EN ALUMINIUM

Barra aluminio soporte estante, especial para estantes de gran longitud.

Aluminium bar for shelf support, recommended for high length shelves.

La barre de support de plateau en aluminium, longueurs d'étagères spéciaux.



El set incluye barra aluminio + 2 soportes fijación + soporte central
The set includes aluminium bar + 2 fixing supports + central support
L'ensemble comprend barre aluminium + 2 supports de fixation + support central.

	Cod.
$a \downarrow$	848010
45	45
56	56
70	70

SOPORTE ESTANTE CUADRATO (JUEGO DE 2 Unds.)

SQUARE SHELF SUPPORT (SET OF 2 Pcs) | APPUI GALERIE QUADRATUS (JEU DE 2 PIÈCES)

Juego soporte galería cuadrato, para estante de diferente grosor.

Square shelf support for different thick shelf.

Support galerie quadratus pour different épaisseur d'étagère.

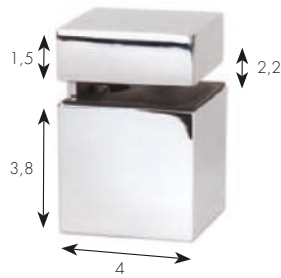

Cromo Mate
Matt chrome | Chrome mat. **Cod.**
848206 - CM

SOPORTE ESTANTE RECTÁNGULO (JUEGO DE 2 Unds.)

RECTANGLE SHELF SUPPORT (SET OF 2 Pcs) | APPUI GALERIE RECTANGLE (JEU DE 2 PIÈCES)

Juego soporte galería rectángulo, para estante de diferente grosor.

Rectangle shelf support for different thick shelf.

Support galerie rectangle pour different épaisseur d'étagère.



Cromo Mate
Matt.Chrome | Chrome Mat. **Cod.**
848204 - CM

SOPORTE ESTANTE PELÍCANO (JUEGO DE 2 Unds.)

PELICANO SHELF SUPPORT (SET OF 2 Pcs) | APPUI GALERIE PÉLICAN (JEU DE 2 PIÈCES)

Juego soporte galería Pelicano, para estante de diferente grosor.

Pelicano shelf support for different thick shelf.

Support galerie Pelican pour different épaisseur d'étagère.

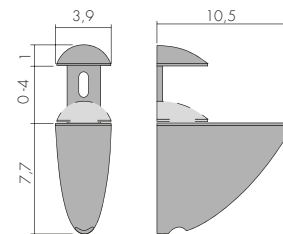

Cromo mate
Matt chrome | Chrome mat. **Cod.**
848202 - C

NEW

PROTECTOR FREGADERO ABS GRIS F50-16

GRAY ABS SINK PROTECTOR F50-16 | PROTECTEUR D'ÉVIER EN ABS GRIS F50-16

Protector ABS gris fondo 50 cm. para mueble fregadero.

Grey ABS sink protector 50 cm. depth for sink cabinet.

Protecteur ABS gris 50 cm. de fond pour meuble évier.

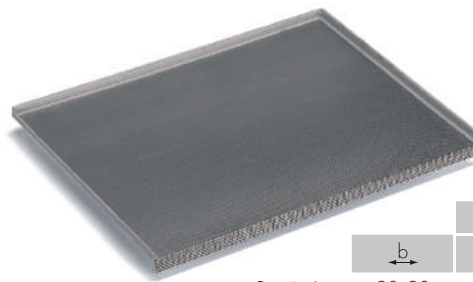

Tablero 16
Board 16
Planche 16

		Cod.
	b	849111
	45	45-16
	50	50-16
	60	60-16
	70	70-16
	80	80-16
	90	90-16
Rincón L	93x93	93-16
Rincón L	108x108	108-16

NEW

PROTECTOR FONDO FREGADERO TERMOPLÁSTICO ANTRACITA F50-19

ANTHRACITE THERMOPLASTIC SINK PROTECTOR F50-19 | PROTECTEUR D'ÉVIER THERMOPLASTIQUE ANTHRACITE F50-19

Protector termoplástico fondo 50, para mueble fregadero.

Thermoplastic protector 50 cm. depth for sink cabinet.

Protecteur thermoplastique en bas 50, pour meuble évier.



Tablero 19
Board 19
Planche 19

		Cod.
	b	849121
	45	45-19
	50	50-19
	60	60-19
	70	70-19
	80	80-19
	90	90-19
	100	100-19
	120	120-19

ROLLO ALFOMBRILLA PROTECTORA CAJÓN FREGADERO



ANTISLIP MAT ROLL FOR DRAWER | ROULER DE TAPIS DE PROTECTION TIROIR D'ÉVIER

Rollo alfombra antideslizante para fondo de cajón o fregadero, con espesor de 1,2.

Antislip mat roll for drawer or sink bottom, 1,2 cm thick.

Tapis de protection rouler pour tiroir d'évier avec 1,2 épaisseur.



	Mts	Rollo 20 mts.
 Esfera acabado Blanco Finished sphere White Finitions sphère Blanc	849103-TB	849104-TB
 Esfera acabado Gris Finished sphere Gray Finitions sphère Gris	849103-TG	849104-TG
 Esfera acabado Antracita Finished sphere Anthracite Finitions sphère Anthracite	849103-TA	849104-TA

PROTECTOR HORNO ALUMINIO (JUEGO DE 2 Unds.)

OVEN PROTECTOR ALUMINIUM TAPE SET | PROTECTEUR ALUMINIUM FOUR (JEU DE 2)

Juego pletina aluminio protector de horno de 60 cms, con tira adhesiva y perforada.

Oven protector aluminium tape set with adhesive and drilled strip.

Jeu de plaque aluminium de protection four de 60 cm, avec bande adhésive perforée.



Cod.
849202

JUEGO PROTECTOR LATERAL DE CAMPANA



HOOD SIDE METAL PROTECTOR SET | PROTECTEUR DE HOTTE

Juego protector lateral campana metálico.

Hood side metal protector set.

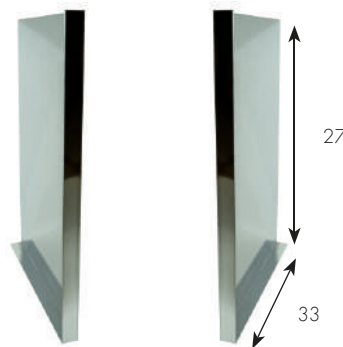
Protecteur côté hotte métal.



	Cod.
 Blanco White Blanc	849301
 Negro Black Noir	849302
 Inox Inox Inox	849303

BASE VENTILACIÓN COLUMNA FRIGO INTEGRABLE

INTEGRABLE COLUMN REFRIGERATOR VENTILATION BASE | FAN DE BASE COLONNE FRIGO INTEGRABLE

Base en material termoplástico con alta resistencia a altas y bajas temperaturas.

Base in thermoplastic material with high resistance to high and low temperatures.

Base de matière thermoplastique à haute résistance aux températures élevées et basses.



xx=16 (tablero board planche 16)
xx=19 (tablero board planche 19)
Cod.
846901-xx

PERFIL PROTECTOR COSTADO SUELO

PROTECTIVE PROFILE SIDE FLOOR | SOL PROFIL DE CÔTÉ DE PROTECTION

Perfil ABS antihumedad para costados.
Profile Anti-Moisture ABS for sides.
Anti-humidité ABS profil de flanc.



		Cod.
Aluminio Aluminum Aluminium		849401 - A
Negro Black Noir		849401 - N

CERCO CAJEO SALVA-SIFÓN PLÁSTICO

PERIMETRAL EDGE SAVE-SIPHON PLASTIC | COURBE SOUS-ÉVIER EN PLASTIQUE

Accesorio ABS para muebles con bajada de sifón.
ABS accessory for furniture with siphon down.
Accessoires Meubles ABS avec siphon réduit.

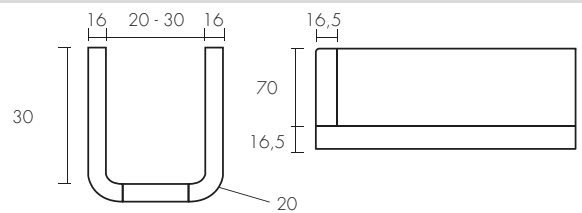

			Cod.
20	Blanco White Blanc		81Z616
30	Gris Gray Gris		81Z616
	Antracita Anthracite Anthracite		81Z616

CERCO CAJEO SALVA-SIFÓN METÁLICO

PERIMETRAL EDGE SAVE-SIPHON METAL | COURBE SOUS-ÉVIER MÉTALLIQUE

Accesorio metálico para muebles con bajada de sifón.
ABS accessory for furniture with siphon down.
Accessoires meubles métallique avec siphon réduit.

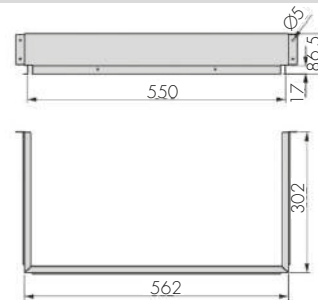

		Cod.
Gris Gray Gris		81Z601

SISTEMA ELEVABLE MICROONDAS HIDRÁULICO

MICROWAVE OPENING SYSTEM | SYSTÈME D'OVERTURE RELEVABLE MICROONDES

Sistema apertura elevable microondas, regulable al ancho.
Opening system lifting for microwave, adjustable to width.
Système d'ouverture relevable microondes largeur réglable.

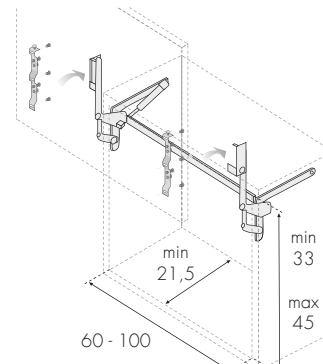

Cod.
833001



SERIE LÁMINA



Base de aluminio cerrada.
Closed aluminum base.
Base en aluminium fermée.

CARACTERÍSTICAS GENERALES i

La nueva serie Lámina, incorpora bandejas cerradas en una única pieza de aluminio, en color antracita, con cierre amortiguado y guías Grass de 40 kilos.

The new Lamina series, it incorporates trays closed in a single piece of aluminum, in anthracite color, with cushioned closure and Grass guides of 40 kilos.

La nouvelle série lamina il incorpore des plateaux fermés d'une seule pièce d'aluminium, de couleur anthracite, avec une fermeture rembourrée et des guides Grass de 40 kg.



Sistema de cierre amortiguado.
Soft closing.
Système de fermeture amortisseur.

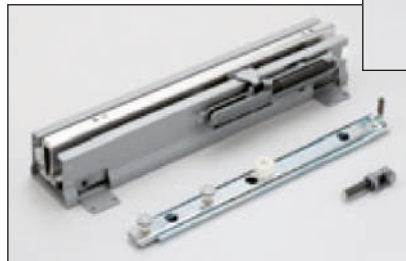

Antracita
Anthracite
Anthracite



LÁMINA - MÓDULO BOTELLERO-VERDULERO E/FRONTAL

LÁMINA - VEGETABLE/BOTTLE PULL-OUT WFB | LÁMINA - COMBINÉ BOUTEILLE/LEGUMES FRONTAL

Adaptable para módulos desde 16/18/19 mm de grosor.

Adjustable to 16/18/19mm cabinet thickness.

Adaptable à caissons de 16/18/19mm d'épaisseur.



		Cod.
		861416
Frontal	30	30 F
Frontal	40	40 F
Frontal	45	45 F
Frontal	60	60 F

LÁMINA - MÓDULO BOTELLERO-PANERO E/FRONTAL

LÁMINA - BOTTLE/BREAD PULL-OUT WFB | LÁMINA - COMBINÉ PAIN BOUTEILLE FRONTAL

Adaptable para módulos de 16/18/19 mm de grosor .

Adjustable to 16/18/19mm cabinet thickness.

Adaptable à caissons de 16/18/19mm d'épaisseur.



		Cod.
		861411
Frontal	30	30 F

LÁMINA - MÓDULO BOTELLERO E/FRONTAL

LÁMINA - BOTTLE PULL-OUT WFB | LÁMINA - BOUTEILLE FRONTAL

Adaptable para módulos desde 16/18/19 mm de grosor.
Adjustable to 16/18/19mm cabinet thickness.
Adaptable à caissons de 16/18/19mm d'épaisseur.



		Cod.
		861421
Frontal	15	15 F

LÁMINA - RINCÓN ARTICULADO FLYBOX

LÁMINA - ARTICULATED CORNER FLYBOX | LÁMINA - FLYBOX D'ANGLE ARTICULÉ

Sistema extraíble de cuatro cestas para rincón con apertura en un solo movimiento.
Removable system of four corner baskets with opening in a single movement.
Système amovible de quatre paniers d'angle avec ouverture en un seul mouvement.



		Cod.
		861471
Frontal	45	45 F
Frontal	60	60 F

LÁMINA - EXTRAÍBLE RINCONERO FLY MOON

LÁMINA - REMOVABLE CORNER FLY MOON | LÁMINA - COIN AMOVIBLE FLY MOON

Sistema extraíble de rincón con sistema de apertura de un solo movimiento.
Removable corner system with one-movement opening system.
Système d'angle amovible avec système d'ouverture à un mouvement.

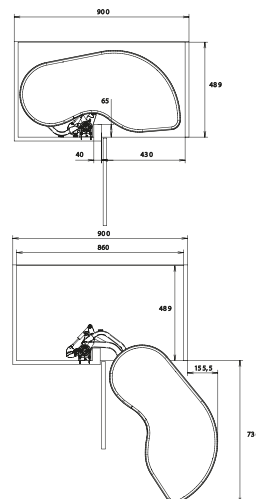

		Cod.
		861451
45	D	45 D
45	I	45 I
60	D	45 D
60	I	60 I

LÁMINA - BASTIDOR COLUMNA EXTRAÍBLE 176-220 (6 CESTILLOS)

LÁMINA - CENTRE UPRIGHT FRAME (6 BASKETS) - LÁMINA - CADRE COLONNE AMOVIBLE 190-230 (6 PANIERS)

Altura regulable. Con sistema de regulación en 3D perfecto para el ajuste de la puerta.
Extracción total.
Cierre amortiguado.
6 cestillos.
También disponible en:
146-190 (4-5 cestillos) 

Adjustable Heigt. 3D adjustable for perfect fitting to the door.
Total extraction.
Soft closing.
6 baskets.
Also available in:
146-190 (4-5 baskets) 

Hauteur regulable avec système de regulation dans 3D parfait pour l'ajustement de la porte.
Extraction total.
Fermeture amorti.
6 paniers.
Egalement disponible en:
146-190 (4-5 paniers) 



	∅	H	Cod.
	176 - 220	15	861491
	176 - 220	30	30
	176 - 220	40	40
	176 - 220	45	45
	176 - 220	60	60

LÁMINA - CONJUNTO COLUMNA MAXI 1920-2180 (5 CESTILLOS)

LÁMINA - COLUMN SET MAXI 1920-2180 (5 BASKETS) | LÁMINA - COLUMN SET MAXI 1920-2180 (5 PANIER)

Sistema de organización extraíble para columnas con nuevas bandejas en una única pieza color antracita.

Removable organization system for columns with new trays in a single anthracite colored piece.

Système d'organisation amovible pour colonnes avec de nouveaux plateaux en une seule pièce de couleur anthracite.



	∅	Cod.
	45	861496
	60	60



SERIE COMPACT

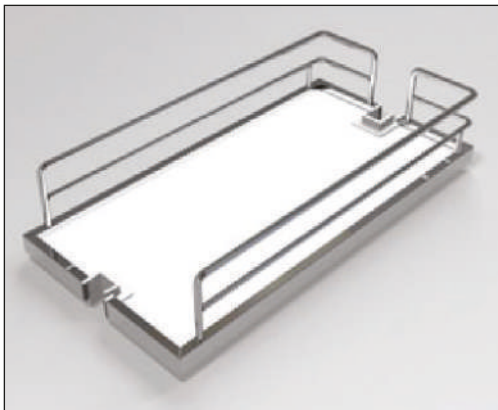

Base de melamina antideslizante blanca.
Antislip white melamine base.
Fond mélaminé antidérapant blanc.

CARACTERÍSTICAS GENERALES i

La SERIE COMPACT está compuesta por una línea de herrajes de alta calidad con los últimos sistemas de amortiguación y superficies en melamina blanca antideslizante y guías de 40 Kg.

COMPACT SERIES consist on a line of high quality hardware with the last damping system and white antislip melamine surfaces and 40 Kg guides.

La SÉRIE COMPACT est composée d'une ligne de ferrages de qualité avec les derniers systèmes d'amortissement et surfaces de glissement de mélaminé blanc et 40 Kg guides.



Sistema de cierre amortiguado.
Soft closing.
Système de fermeture amortisseur.



Cromo brillo
Shining Chrome
Chrome brillant



COMPACT - MÓDULO BOTELLERO-VERDULERO E/FRONTAL

COMPACT - VEGETABLE/BOTTLE PULL-OUT WFB | COMPACT - COMBINÉ BOUTEILLE/LEGUMES FRONTAL

Adaptable para módulos desde 16/18/19 mm de grosor.
Adjustable to 16/18/19mm cabinet thickness.
Adaptable à caissons de 16/18/19mm d'épaisseur.



		Cod.	
		861016	
Frontal	30	30 F	
Frontal	40	40 F	

COMPACT - MÓDULO BOTELLERO-PANERO E/FRONTAL

COMPACT - BOTTLE/BREAD PULL-OUT WFB | COMPACT - COMBINÉ PAIN BOUTEILLE FRONTAL

Adaptable para módulos de 16/18/19 mm de grosor.
Adjustable to 16/18/19mm cabinet thickness.
Adaptable à caissons de 16/18/19mm d'épaisseur.



		Cod.	
		861011	
Frontal	30	30 F	
Frontal	40	40 F	

COMPACT - MÓDULO BOTELLERO FRONTAL

COMPACT - BOTTLES PULL-OUT | COMPACT - MODULE BOUTEILLES

Adaptable para módulos de 16/18/19 mm de grosor.

Adjustable to 16/18/19 mm cabinet thickness.

Adaptable à caissons de 16/18/19mm d'épaisseur.

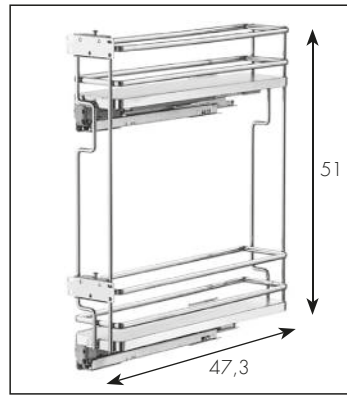

Altura	Cod.
15	861021
20	861022

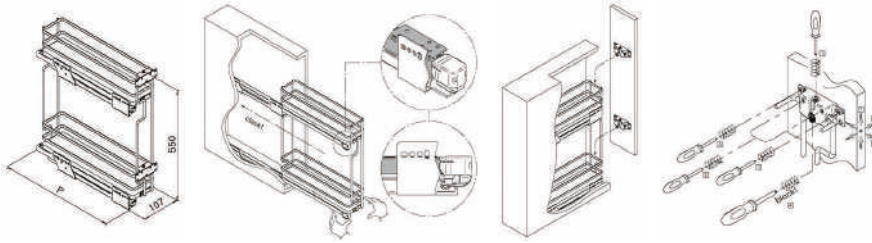

SOPORTE SEPARADOR BOTELLERO BOTTLES DIVIDER | DIVISEUR BOUTEILLES

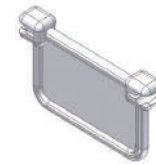

ABS / Poliamida.
ABS / Polyamide.
ABS / Polyamide.

Incluido en botellero
Included in bottle rack
Inclus dans le casier à bouteilles

COMPACT - CESTILLO MULTIUSO EXTRA

COMPACT - PULL-OUT BASKET | COMPACT - CORBEILLE

Guías ocultas, extracción total y cierre amortiguado. Adaptable para módulos de 16/18/19 de grosor.

Hidden guides total extraction, soft closing, Adjustable to 16/18/19 cabinet thickness.

Système de fermeture amottisseur. Adaptable à caissons de 16/18/19 d'épaisseur.

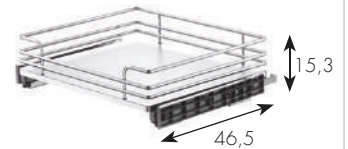

Altura	Cod.
40	861041
45	45
60	60

COMPACT - CONJUNTO BANDEJA GIRATORIA 270° A

COMPACT - 270° SWIVEL BASKET | COMPACT - TOURNIQUET 270°

Eje regulable desde 630 - 730 mm. Sistema de freno.

Adjustable axle 630 - 730 mm. Brake system.

Axe réglable de 630 - 730 mm. Système de freinage.



Para Ø 71 - L Min 80 / F Min 46
Para Ø 81 - L Min 90 / F Min 51

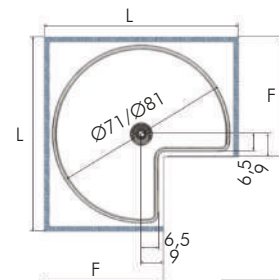

Ø	Cod.
71	861081
81	81

COMPACT - BANDEJA RINCÓN UNIKO DESLIZANTE

COMPACT - UNIKO CORNER TRAY SLIDING | COMPACT - PLATEAU COIN UNIKO COULISSANT

Bandeja rincón independiente y reversible con doble sujeción
Independent and reversible corner tray with double fixing
Plateau d'angle indépendant et réversible à double fixation

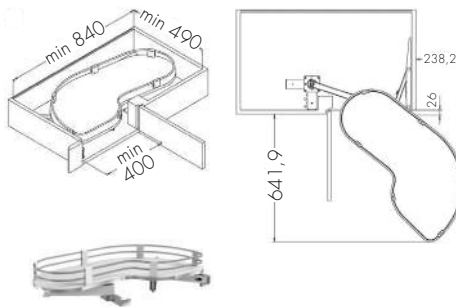

Cod.	
45	861056
60	60

COMPACT - CONJUNTO RINCÓN FLY BANDEJAS DESLIZANTES

COMPACT - CORNER SET FLY SLIDING TRAYS | COMPACT - COIN SET FLY PLATEAUX COULISSANTS

Base melamina antideslizante.
Eje regulable desde 665 - 705 mm
Antislip melamine base.
Adjustable axle 665 - 705 mm
Glissement de mélamine.
Axe réglable de 665 - 705 mm

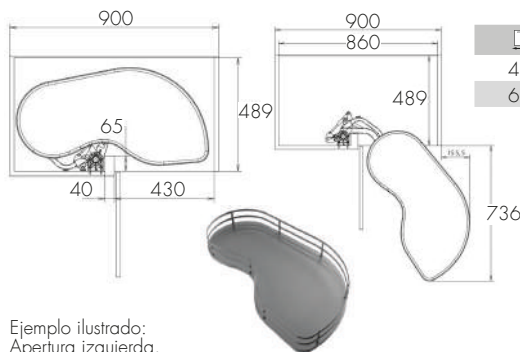

	d(min)	e(min)
45	900	min. 411
60	1000	min. 561

Cod.	
40 D	861051
40 I	40 D
45 D	45 D
45 I	45 I
60 D	60 D
60 I	60 I

Ejemplo ilustrado:
Apertura izquierda.

COMPACT - CONJUNTO BASTIDOR RINCÓN ARTICULADO

COMPACT - ARTICULATED PULL - OUT | COMPACT - CADRE MÉDIAN EXT. ART.

Bandejas de melamina blanca, antideslizantes, regulables en 3 alturas.
Bandejas interiores 9,5 Kg.
Bandejas exteriores 8 Kg.
Antislip melamine base, 3 heights adjustable.
Interior basket 9,5 Kg
Front basket 8 Kg
Base mélamine antideslissante, réglable en 3 hauteurs
Panier intérieur 9,5 Kg
Panier frontal 8 Kg



Ejemplo ilustrado: apertura izquierda
Illustrated example: left opening
Exemple illustré: Ouverture à gauche

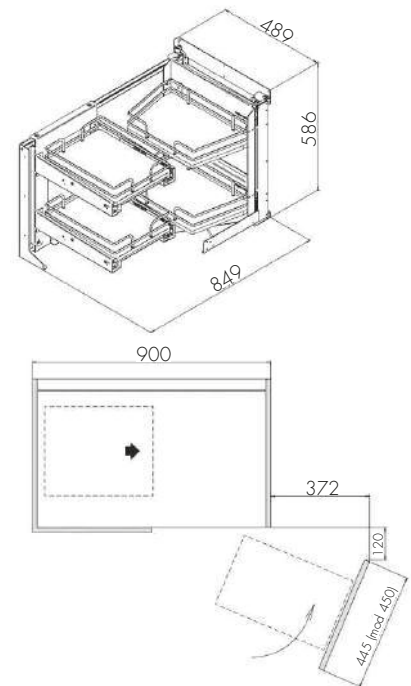
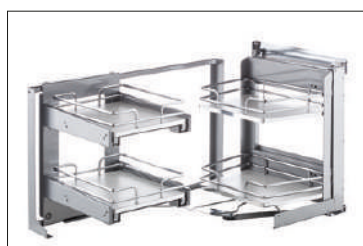

Cod.	
45 D	861071
45 I	45 D
45 I	45 I

COMPACT - CONJUNTO COLUMNA MAXI 1920-2180 (5 CESTILLOS)

COMPACT - COLUMN SET MAXI 1920-2180 (5 BASKETS) | COMPACT - COLUMN SET MAXI 1920-2180 (5 PANIERS)

La columna Maxi con base melamina blanca antideslizante y doble varilla nos permite un acceso frontal y lateral.

The Maxi column with white non-slip melamine base and double rod allows us a frontal and lateral access.

La columna Maxi avec base en mélamine blanche antidérapante et double tige nous permet un accès frontal et latéral.

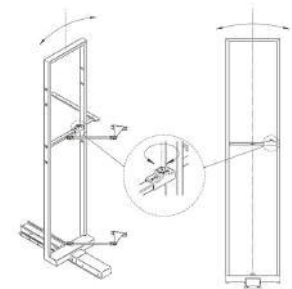
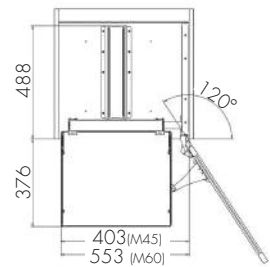
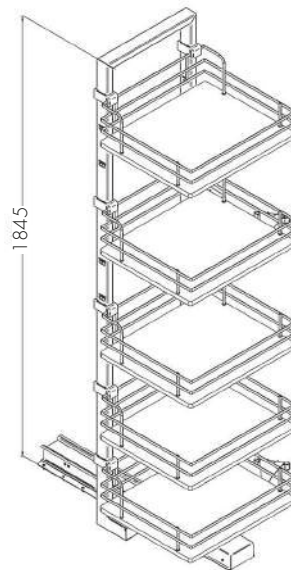

	Cod.
Ø	861096
45	45
60	60

COMPACT - BASTIDOR COLUMNA EXTRAÍBLE 176-220 (6 CESTILLOS)

COMPACT - CENTRE UPRIGHT FRAME (6 BASKETS) - COMPACT - CADRE COLONNE AMOVIBLE 190-230 (6 PANIERS)

Altura regulable. Con sistema de regulación en 3D perfecto para el ajuste de la puerta.

Extracción total.

Cierre amortiguado.

6 cestillos.

También disponible en:  146-190 (4-5 cestillos)

Adjustable Height. 3D adjustable for perfect fitting to the door.

Total extraction.

Soft closing.

6 baskets.

Also available in:  146-190 (4-5 baskets)

Hauteur regulable avec système de régulation en 3D parfait pour l'ajustement de la porte.

Extraction total.

Fermeture amorti.

6 paniers.

Egalement disponible en:  146-190 (4-5 paniers)



Cesta base melamina antideslizante.
Non-slip melamine base basket.
Panier de base en mélamine antidérapant.



Altura regulable / Adjustable height
Hauteur réglable.



Cestas de fácil montaje.
Easy-to-assemble baskets.
Paniers faciles à monter.

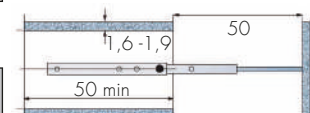

		Cod.
qt	☐	861091
176 - 220	30	30
176 - 220	40	40
176 - 220	45	45
176 - 220	50	50
176 - 220	60	60



SERIE COMPACT ANTRACITA

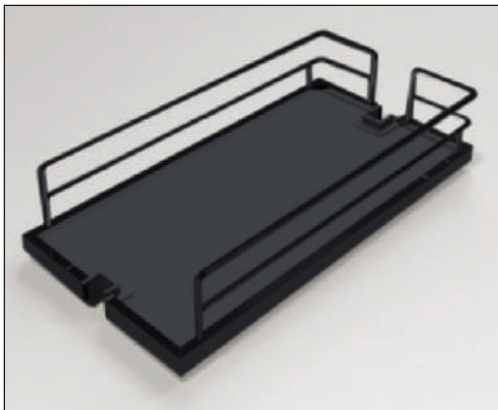

Base de melamina antideslizante antracita.
Antislip white anthracite base.
Fond mélaminé antidérapant anthracite.

CARACTERÍSTICAS GENERALES

La SERIE COMPACT está compuesta por una línea de herrajes de alta calidad con los últimos sistemas de amortiguación y superficies en melamina antracita antideslizante y guías de 40 Kg.

The COMPACT SERIES is composed of a line of fittings from High quality with the latest cushioning systems and surfaces in anti-slip anthracite melamine and 40 Kg guides.

La SÉRIE COMPACT est composée d'une ligne de robinetterie de Haute qualité avec les derniers systèmes d'amortissement et de surfaces en mélamine anthracite antidérapante et 40 Kg guides.



Sistema de cierre amortiguado.
Soft closing.
Système de fermeture amortisseur.

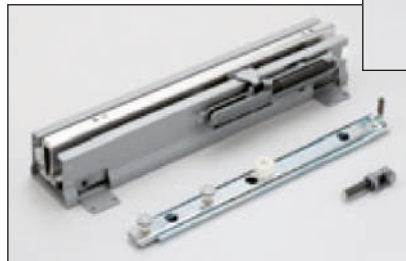

Antracita
Anthracite
Anthracite



COMPACT - MÓDULO BOTELLERO/VERDULERO E/FRONTAL

COMPACT - VEGETABLE/BOTTLE PULL-OUT WFB | COMPACT - COMBINÉ BOUTEILLE/LEGUMES FRONTAL

Adaptable para módulos desde 16/18/19 mm de grosor. Antracita.
Adjustable to 16/18/19mm cabinet thickness. Anthracite.
Adaptable à caissons de 16/18/19mm d'épaisseur. Anthracite.

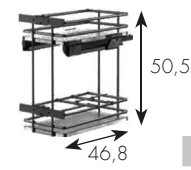

		Cod.
		861216
Frontal	30	30 F
Frontal	40	40 F

COMPACT - MÓDULO BOTELLERO-PANERO E/FRONTAL

COMPACT - BOTTLE/BREAD PULL-OUT WFB | COMPACT - COMBINÉ PAIN BOUTEILLE FRONTAL

Adaptable para módulos de 16/18/19 mm de grosor. Antracita.
Adjustable to 16/18/19mm cabinet thickness. Anthracite.
Adaptable à caissons de 16/18/19mm d'épaisseur. Anthracite.



		Cod.
		861211
Frontal	30	30 F
Frontal	40	40 F

COMPACT - BANDEJA RINCÓN UNIKO DESLIZANTE

COMPACT - UNIKO CORNER TRAY SLIDING | COMPACT - PLATEAU COIN UNIKO COULISSANT

Bandeja rincón independiente y reversible con doble sujeción antracita.

Independent and reversible corner tray with double fixing anthracite.

Plateau d'angle indépendant et réversible à double fixation anthracite.

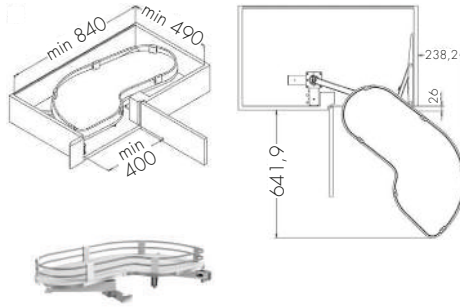

	Cod.
45	861256
60	60

COMPACT - CONJUNTO RINCÓN FLY BANDEJAS DESLIZANTES

COMPACT - CORNER SET FLY SLIDING TRAYS | COMPACT - COIN SET FLY PLATEAUX COULISSANTS

Base melamina antideslizante. Eje regulable desde 665 - 705 mm antracita.

Antislip melamine base. Adjustable axle 665 - 705 mm anthracite.

Glissement de mélamine. Axe réglable de 665 - 705 mm anthracite.

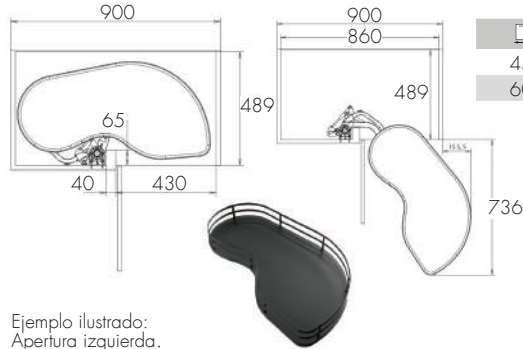

Ejemplo ilustrado: Apertura izquierda.

	d(min)	e(min)
45	900	min. 411
60	1000	min. 561

	Cod.
40 D	861251
40 I	40 D
45 D	40 I
45 I	45 D
60 D	45 I
60 I	60 D
	60 I

COMPACT - MÓDULO BOTELLERO FRONTAL

COMPACT - BOTTLES PULL-OUT | COMPACT - MODULE BOUTEILLES

Adaptable para módulos de 16/18/19 mm de grosor.

Adjustable to 16/18/19 mm cabinet thickness.

Adaptable à caissons de 16/18/19mm d'épaisseur.



	Cod.
15	861221
20	861222

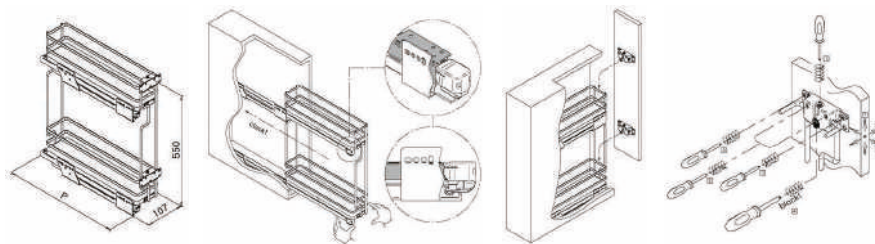

SOPORTE SEPARADOR BOTELLERO BOTTLES DIVIDER | DIVISEUR BOUTEILLES



ABS / Poliamida.
ABS / Polyamide.
ABS / Polyamide.

Incluido en botellero
Included in bottle rack
Inclus dans le casier à bouteilles

COMPACT - CONJUNTO BASTIDOR RINCÓN ARTICULADO

COMPACT - ARTICULATED PULL - OUT | COMPACT - CADRE MÉDIAN EXT. ART.

Bandejas de melamina antracita, antideslizantes, regulables en 3 alturas.

Bandejas interiores 9,5 Kg.

Bandejas exteriores 8 Kg.

Antislip melamine base anthracite, 3 heights adjustable.

Interior basket 9,5 Kg

Front basket 8 Kg

Base mélamine anthracite antidérapante, réglable en 3 hauteurs

Panier intérieur 9,5 Kg

Panier frontal 8 Kg



Ejemplo ilustrado: apertura izquierda
Illustrated example: left opening
Exemple illustré: ouverture à gauche

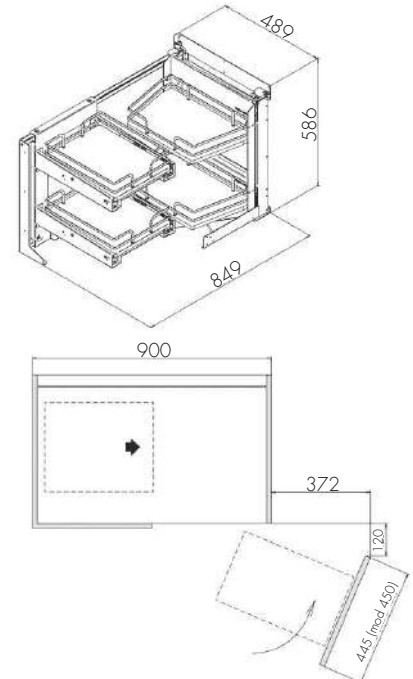

Cod.	
Ø	861271
45 D	45 D
45 I	45 I

COMPACT - CONJUNTO COLUMNA MAXI 1920-2180 (5 CESTILLOS)

COMPACT - COLUMN SET MAXI 1920-2180 (5 BASKETS) | COMPACT - COLUMN SET MAXI 1920-2180 (5 PANIER)

La columna Maxi con base melamina antracita antideslizante y doble varilla nos permite un acceso frontal y lateral.

The Maxi column with anthracite non-slip melamine base and double rod allows us a frontal and lateral access.

La colonne Maxi avec base en mélamine anthracite antidérapante et double tige nous permet un accès frontal et latéral.

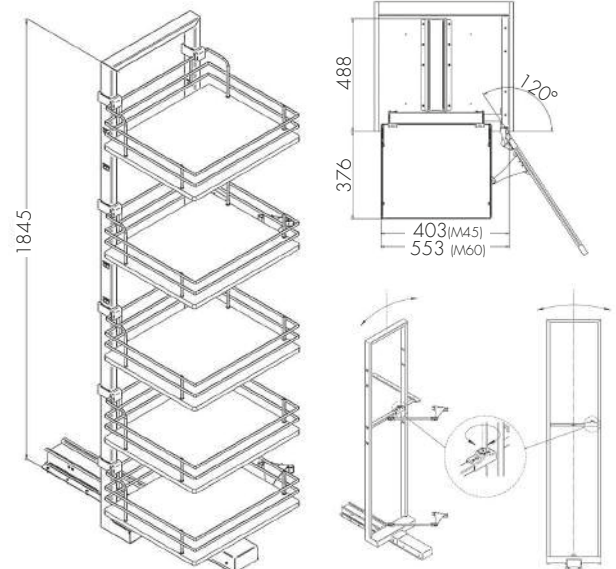

Cod.	
Ø	861296
45	45
60	60

SERIE LUX

CARACTERÍSTICAS GENERALES i

La SERIE LUX está basada en herrajes de varilla cromada, con guía de cierre amortiguado. La serie se completa con los herrajes de rincón con base en PVC gris.

LUX SERIES is based on chrome dipstick ironwork. Fittings with soft closing guide. The series is complete with corner ironwork PVC based gray.

La SERIE LUX est basée sur ferrages chromé avec des coulisses de clôture. La série se complète de ferrage d'angle et base en PVC gris.

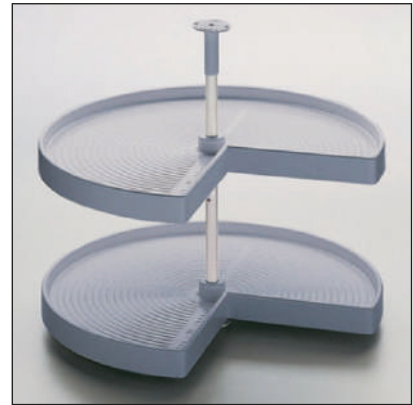
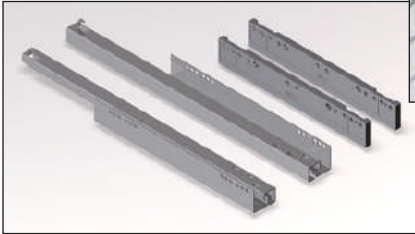
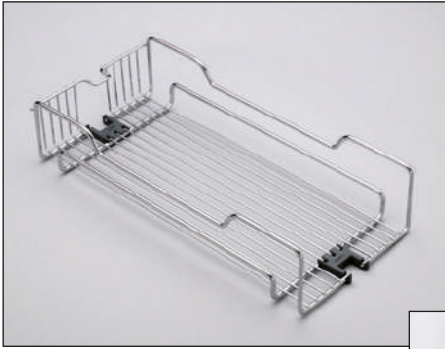

Guías correderas de rodillos de acero y cierre amortiguado.
Roll bearing runners included and soft close.
Coulisses à rouleaux en acier incluses et Système de fermeture amattisseur.

Cromo brillo
Shining Chrome
Chrome brillant



LUX - MÓDULO ACCESORIO LIMPIEZA

LUX - PULL-OUT CLEANING BASKET | LUX - MODULE PRODUITS D'ENTRETIEN

Para puerta con bisagras. Extracción total, con cierre amortiguado. Adaptable para módulos de 16/18/19mm de grosor.

For hinged door. Soft closing Full extension. Adjustable to 16/18/19mm cabinet thickness.

Pour porte à charnières. Extraction totale. Adaptable à caisson de 16/18/19mm d'épaisseur.

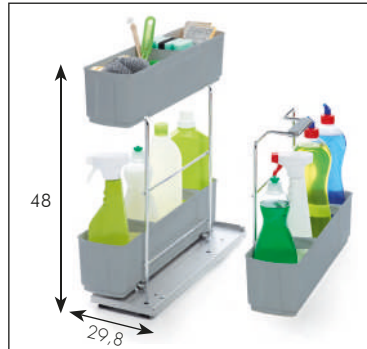

Cod.	
D	862001
30 D	D
30 I	I

LUX - CONJUNTO BANDEJA GIRATORIA 270°

LUX - 270° SWIVEL BASKET | LUX - TOURNIQUET 270°

Eje regulable desde 690 - 750 mm y sistema de freno. Bandejas con giro independiente.

Height adjustable axle from 69 cm to 75 cm and brake-system. Each basket rotates and stop independently.

Avec axe de réglage de 69 cm jusqu'à 75 cm de hauteur et système de frein. Plateaux tournant indépendamment.

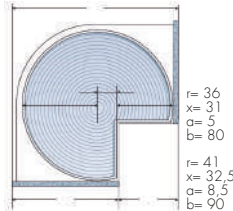

Polipropileno

D	Ø		Cod.
25	72	Blanco White Blanc	862051-B
35	82	Gris Gray Gris	862051-G

LUX - MÓDULO BOTELLERO 15 E/FRONTAL

LUX - BOTTLES PULL-OUT W.F.B. | LUX - MOD. BOUTEILLE FIX. FR.

Extracción total. Adaptable para módulos de 16/18/19mm de grosor.

Full extension. Adjustable to 16/18/19mm cabinet thickness.

Extraction totale. Adaptable à caissons de 16/18/19mm d'épaisseur.

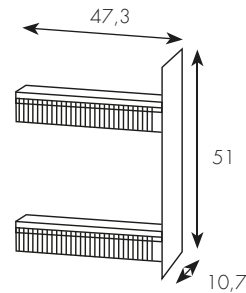

		Cod.
Frontal	15	862021
		15

LUX - MÓDULO BOTELLERO 20 E/FRONTAL

LUX - BOTTLES PULL-OUT W.F.B. | LUX - MOD. BOUTEILLE FIX. FR.

Extracción total. Adaptable para módulos de 16/18/19mm de grosor.

Full extension. Adjustable to 16/18/19mm cabinet thickness.

Extraction totale. Adaptable à caissons de 16/18/19mm d'épaisseur.

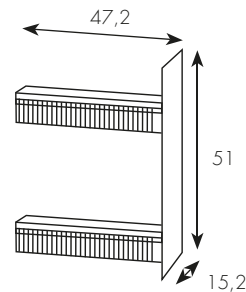

		Cod.
Frontal	20	862022
		20 F

LUX - MÓDULO BOTELLERO-PANERO E/FRONTAL

LUX - BOTTLES PULL-OUT | LUX - COMBINE PAIN BOUTEILLE

Extracción total, con cierre amortiguado. Adaptable para módulos de 16/18/19mm de grosor.

Full extension. Soft closing. Adjustable to 16/18/19mm cabinet thickness.

Extraction totale. Adaptable à caisson de 16/18/19mm d'épaisseur.

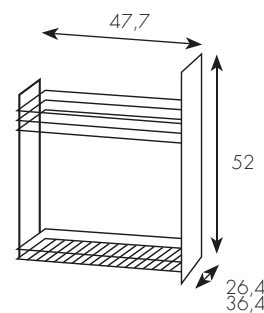

		Cod.
Frontal	30	862011
Frontal	40	30 F
		40 F

LUX - MÓDULO BOTELLERO-VERDULERO E/FRONTAL

LUX - BOTTLES PULL-OUT W.F.B. | LUX - MODULE BOUTEILLES FR.

Extracción total. Adaptable para módulos de 16/18/19mm de grosor.

Full extension. Adjustable to 16/18/19mm cabinet thickness.

Extraction totale. Adaptable à caissons de 16/18/19mm d'épaisseur.

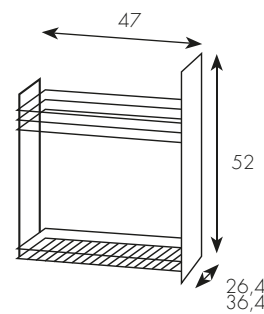

		Cod.
Frontal	30	862031
Frontal	40	30 F
		40 F

LUX - BASTIDOR COLUMNA EXTRAIBLE LIMPIEZA 15

LUX - REMOVABLE COLUMN CLEANING | LUX - NETTOYAGE DE LA COLONNE AMOVIBLE

Bastidor columna limpieza con guía lateral y extracción total.

Cleaning column frame with lateral guide and total extraction.

Colonne de nettoyage avec guidage latéral et extraction totale.

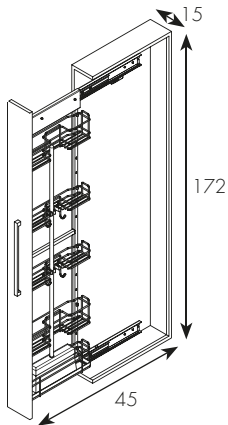

Cod.	
15	86207A
15	15

LUX - BASTIDOR COLUMNA EXTRAIBLE BOTELLERO 15

LUX - REMOVABLE COLUMN BOTTLER | LUX - BOUTEILLE DE COLONNE AMOVIBLE

Bastidor columna botellero con guía lateral y extracción total.

Rack bottle with side guide and total extraction.

Casier à bouteilles avec guidage latéral et extraction totale.

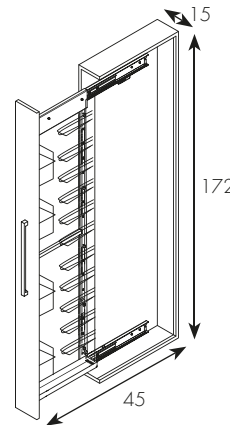

Consultar disponibilidad.
Check availability.
Voir les disponibilités.

Cod.	
15	86207B
15	15

LUX - BASTIDOR COLUMNA EXTRAÍBLE 190-230 (6 CESTILLOS)

LUX - FRAME SET (6 BASKETS) | LUX - KIT CADRE AMOVIBLE 190-230 (6 PANIERS)

Altura regulable. Con sistema de regulación en 3D perfecto para el ajuste de la puerta.

Extracción total.

Cierre amortiguado.

6 cestillos.

También disponible en: 146-190 (4-5 cestillos)

Adjustable height. 3D adjustable for perfect fitting to the door.

Full extension.

Soft closing.

6 baskets.

Also available in: 146-190 (4-5 baskets)

Réglable système de régulation de la hauteur en 3D parfaite pour le réglage de la porte.

Extraction totale.

Fermeture amortisseur.

6 paniers.

Egalement disponible en: 146-190 (4-5 paniers)



Cestillo varillas cromadas.

Basket chrome rods.

Panier tiges chromées.



Fijación extra.

Extra fixation.

Fixation supplémentaire.



Guías cierre amortiguado.

Soft closing guides.

Guides de fermeture en douceur.



		Cod.
ø	15	86207I
190 - 230	30	30
190 - 230	35	35
190 - 230	40	40
190 - 230	45	45
190 - 230	50	50
190 - 230	60	60

LUX - CONJUNTO BASTIDOR RINCÓN ARTICULADO

LUX - ARTICULATED PULL-OUT A | LUX - CADRE MÉDIAN EXT.ART.

Con sistema de cierre amortiguado.
Carga dinámica 9kg cesta interna,
7kg cesta frontal.

With soft closing. Dynamic load 9 kg
interior basket, 7 kg frontal basket.

Avec système de fermeture en dou-
ceur charge dynamique 9kg panier
intérieur.

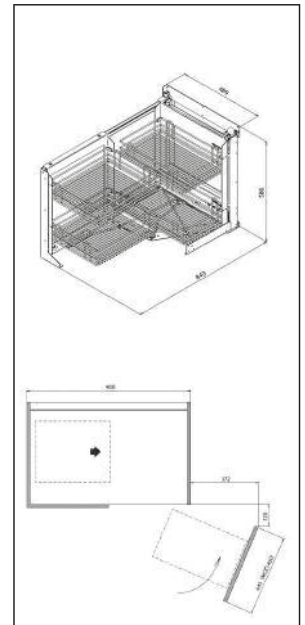

Ejemplo ilustrado: apertura izquierda
Illustrated example: left opening
Exemple illustré: ouverture à gauche

Cod.			
☐	862061		
40	D	40	D
40	I	40	I

LUX - CONJUNTO BASTIDOR RINCÓN MANUAL

LUX - TOTAL EXTRACTABLE CORNER | LUX - ANGLE AMOVIBLE TOTAL

Conjunto bastidor extraíble articulado
rincón ciego, extracción manual. 2
opciones de medida.

Removable articulated pullout blind
corner frame, manual removal. 2
measurement options.

Cadre amovible articulé pour angle
gauche / droite extraction manuel. 2
option de mesure.

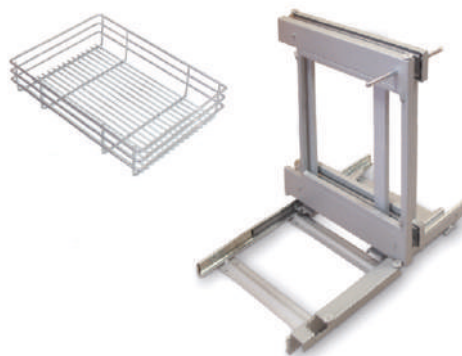

MOD. DERECHA / RIGHT / DROITE

MOD. IZQUIERDA / LEFT / GAUCHE

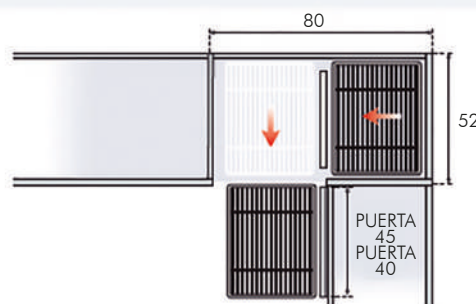
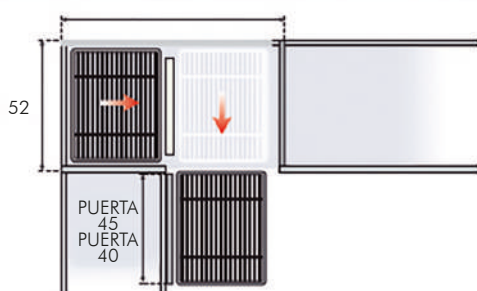

Cod.			
☐	863111		
40	D	80	40 D
40	I	80	40 I
45	D	90	45 D
45	I	90	45 I

LUX - CONJUNTO BANDEJA RINCÓN SPEED

LUX - LAUNDRY BASKET W.F.B. | LUX - PANIER A LINGE FR.

Incluye bisagra Compás.
Extension fitting are included.
Comprend charnière compás.

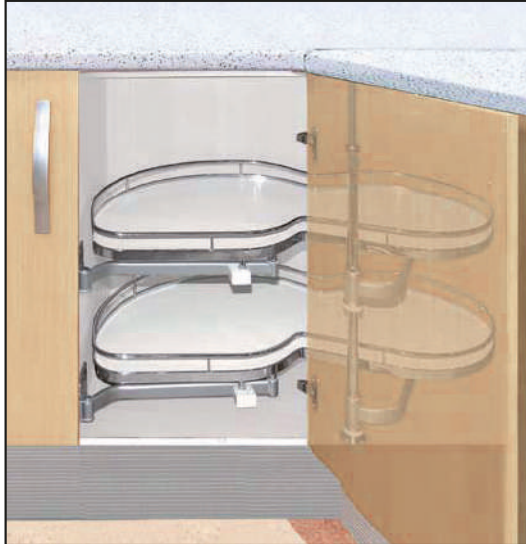

Ejemplo ilustrado: apertura izquierda
Illustrated example: left opening
Exemple illustré: ouverture à gauche

Fondo mínimo interior 50 libre
Minimum interior 50 free background
Intérieur minimum 50 arrière-plan libre

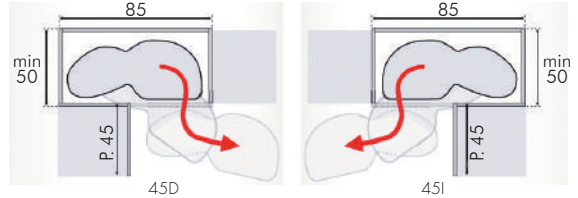

		Cod.
		863061
45	D	45D
45	I	45I

LUX - TOLVA ROPA EXTRAÍBLE ABS BLANCO

LUX - REMOVABLE LAUNDRY BASKET WHITE ABS | LUX - PANIER A LINGE EXTRAIBLE ABS BLANC

Cesto para la ropa en Abs blanco, con guía de extracción total y cierre amortiguado.

Laundry basket in white abs, with full extraction guide and damped closure.

Panier à linge Abs blanc, avec un guide de suppression totale et la fermeture amortie.

* Cajón no incluido
* Drawer not included
* Tiroir non inclus



		Cod.
		862041
	40	40
	50	50
	60	60

LUX - TOLVA ROPA ABATIBLE ABS BLANCO

LUX - LAUNDRY BASKET W.F.B. | LUX - PANIER A LINGE FR.

Tolva ropa abatible, sujeción puerta.

Laundry basket W.F.B.

Panier a linge pliable sujecion porte.

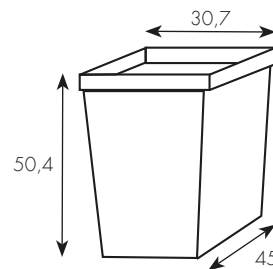

		Cod.
		862046
	45	45

CONTENEDORES RESIDUOS / WASTE CONTAINERS / CONTENANTS À DÉCHETS

CUBO BASURA REDONDO

ROUNDED DUSTBIN | POUBELLE ORDURES RONDE

Cubo basura redondo, apertura sujeción puerta.

Round bin trash, holding door opening.

Poubelle ordures ronde ouverture sujecion porte.

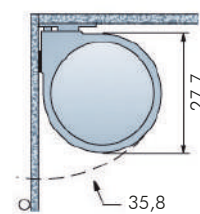
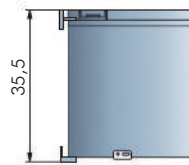

		Cod.
40	Blanco White Blanc	867101
40	Inox Inox Inox	867102

CUBO BASURA RECTANGULAR

RECTANGULAR DUSTBIN | POUBELLE ORDURES RECTANGULAIRE

Cubo de basura rectangular, apertura sujeción puerta.

Square bin trash, holding door opening.

Poubelle ordures rectangulaires ouverture sujecion porte.



	Cod.
30	867111

CUBO BASURA EXTRAÍBLE SIMPLE

SINGLE EXTRACTABLE BUCKET | POUBELLE ORDURES EXTRAIBLE SIMPLE

Cubo basura extraíble simple, extracción manual.

Manual removal, simple pull-out bin trash.

Poubelle ordures extraible simple extraction manuel.

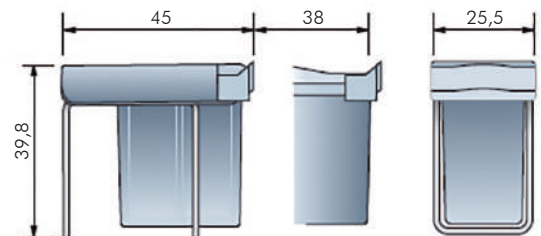

	Cod.
30	867121

CUBO BASURA EXTRAÍBLE DOBLE

DOUBLE EXTRACTABLE BUCKET | POUBELLE ORDURES EXTRAIBLE DOUBLE

Cubo basura extraíble doble, extracción manual.

Manual removal, double pull-out bin trash.

Poubelle ordures extraible double extraction manuel.

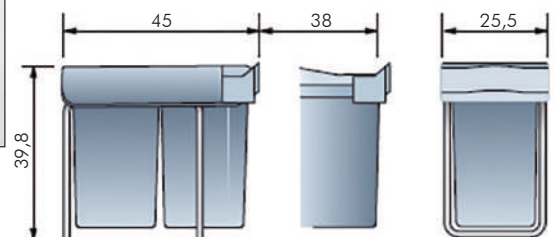

	Cod.
30	867131

CUBO BASURA EXTRAÍBLE DOBLE

BIN TRASH PULL-OUT DOBLE | POUBELLE ORDURES EXTRAIBLE DOBLE

Cubo basura extraíble doble,
apertura sujeción puerta.
Bin trash pull-out double, holding
door opening.
Poubelle ordures extraible double
ouverture sujecion porte.

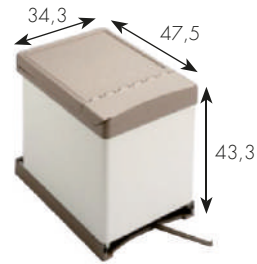
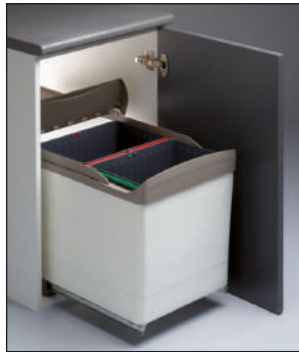

	Cod.
45	867132

CUBO BASURA EXTRAÍBLE INTERIOR MAXI DOBLE

INTERNAL BIN TRASH PULL-OUT DOBLE MAXI | POUBELLE ORDURES EXTRAIBLE INTERNE MAXI DOBLE

Cubo basura maxi extraíble doble,
apertura manual. Inox.
Bin trash pull-out maxi double, holding
door apening. Inox
Poubelle ordures extraible double
maxi ouverture sujecion porte. Inox



		Cod.
16+21 L	45	867151

CUBO BASURA EXTRAÍBLE INTERIOR MAXI TRIPLE

INTERNAL BIN TRASH PULL-OUT TRIPLE MAXI | POUBELLE ORDURES EXTRAIBLE INTERNE MAXI TRIPLE

Cubo basura maxi extraíble triple,
apertura manual. Inox.
Bin trash pull-out maxi triple, holding
door apening. Inox
Poubelle ordures extraible triple maxi
ouverture sujecion porte. Inox



		Cod.
10+10+16 L	45	867152

CUBO BASURA S/CACEROLERO MAXI BIG F/50

BIN TRASH OVER PAN DRAWER MAXI BIG F/50 | POUBELLE ORDURES S/CASSEROLIER MAXI BIG F/50

Cubo basura ecológico
maxi extraíble.
Composición según
medidas.
Ecological maxi removable
trash bin. Composition
according to
measurements.
Poubelle ordures éco maxi
extraible. Composition
selon mesures.

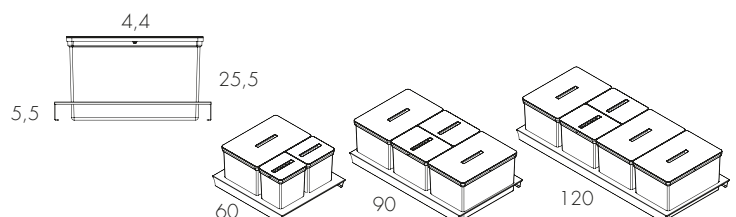

			Cod.
25 + 8 + 8 L	60	Antracita Anthracite Anthracite	807173
25 + 12 + 12 + 25 L	90		
25 + 12 + 12 + 25 + 25 L	120		

CONTENEDORES RESIDUOS / WASTE CONTAINERS / CONTENANTS À DÉCHETS

CUBO BASURA S/CACEROLERO 2 CUBOS

ECOL. WASTE BIN | POUBELLE ÉCO

Cubo basura ecológico s/cacerolero
2 cubos.

Bin trash ecological for pan drawer
2 bins.

Poubelle ordures écologie
s/casserolier, 2 poubelles.



	Cod.
	867162
60	60

CUBO BASURA S/CACEROLERO 3 CUBOS

ECOL. WASTE BIN | POUBELLE ÉCO

Cubo basura ecológico s/cacerolero
3 cubos.

Bin trash ecological for pan drawer
3 bins.

Poubelle ordures écologie
s/casserolier, 3 poubelles.



	Cod.
	867162
80	80

CUBO BASURA S/CACEROLERO 3 CUBOS

ECOL. WASTE BIN | POUBELLE ÉCO

Cubo basura ecológico s/cacerolero
3 cubos.

Bin trash ecological for pan drawer
3 bins.

Poubelle ordures écologie
s/casserolier, 3 poubelles.



	Cod.
	867162
90	90

CUBO BASURA S/CACEROLERO 4 CUBOS

ECOL. WASTE BIN | POUBELLE ÉCO

Cubo basura ecológico s/cacerolero
4 cubos.

Bin trash ecological for pan drawer
4 bins.

Poubelle ordures écologie
s/casserolier, 4 poubelles.



	Cod.
	867162
120	120

CUBO BASURA S/CACEROLERO 2 CUBOS - T/AUTOMATICA

ECOL. WASTE BIN - AUTOMATIC COVER | POUBELLE ÉCO COUVERTURE AUTOMATIQUE

Cubo basura ecológico s/cacerolero 2 cubos con tapa automática.

Bin trash ecological for pan drawer 2 bins with automatic cover.

Poubelle ordures écologie s/casserolier, 2 poubelles avec couvercle automatique.



	Cod.
	867163
60	60

CUBO BASURA S/CACEROLERO 3 CUBOS - T/AUTOMATICA

ECOL. WASTE BIN - AUTOMATIC COVER | POUBELLE ÉCO - COUVERTURE AUTOMATIQUE

Cubo basura ecológico s/cacerolero 3 cubos con tapa automática.

Bin trash ecological for pan drawer 3 bins with automatic cover.

Poubelle ordures écologie s/casserolier, 3 poubelles avec couvercle automatique.



	Cod.
	867163
80	80

CUBO BASURA S/CACEROLERO 3 CUBOS - T/AUTOMATICA

ECOL. WASTE BIN - AUTOMATIC COVER | POUBELLE ÉCO - COUVERTURE AUTOMATIQUE

Cubo basura ecológico s/cacerolero 3 cubos con tapa automática.

Bin trash ecological for pan drawer 3 bins with automatic cover.

Poubelle ordures écologie s/casserolier, 3 poubelles avec couvercle automatique.



	Cod.
	867163
90	90

CUBO BASURA S/CACEROLERO 4 CUBOS - T/AUTOMATICA

ECOL. WASTE BIN - AUTOMATIC COVER | POUBELLE ÉCO - COUVERTURE AUTOMATIQUE

Cubo basura ecológico s/cacerolero 4 cubos con tapa automática.

Bin trash ecological for pan drawer 4 bins with automatic cover.

Poubelle ordures écologie s/casserolier, 4 poubelles avec couvercle automatique.



	Cod.
	867163
120	120

GRAN CAPACIDAD / LARGE CAPACITY / GRANDE CAPACITÉ

CUBO BASURA EXTRAÍBLE PLUS 40

WASTE CUBE REMOVABLE PLUS 40 | GARBAGE PAIL EXTRAIBLE PLUS 40

Cubo basura gran capacidad con guías de extracción total, 40 Kg y cierre amortiguado.

Great capacity waste cube with guides total extraction, 40 Kg and closure damaged.

Garbage grande capacité avec guides d'extraction totale, 40 kg et fermeture amortis.

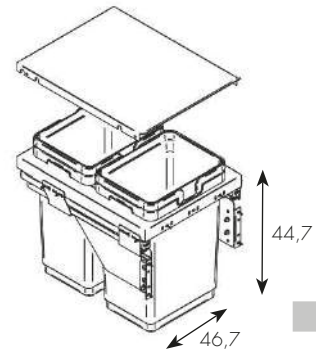

	Cod.
	867156
40	40

CUBO BASURA EXTRAÍBLE PLUS 45

WASTE CUBE REMOVABLE PLUS 45 | GARBAGE PAIL EXTRAIBLE PLUS 45

Cubo basura gran capacidad con guías de extracción total, 40 Kg y cierre amortiguado.

Great capacity waste cube with guides total extraction, 40 Kg and closure damaged.

Garbage grande capacité avec guides d'extraction totale, 40 kg et fermeture amortis.

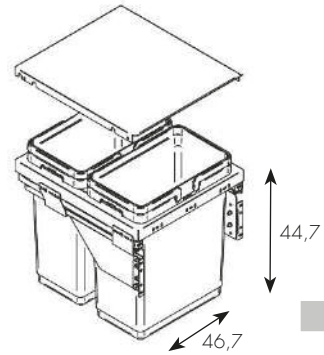

	Cod.
	867156
45	45

CUBO BASURA EXTRAÍBLE PLUS 50

WASTE CUBE REMOVABLE PLUS 50 | GARBAGE PAIL EXTRAIBLE PLUS 50

Cubo basura gran capacidad con guías de extracción total, 40 Kg y cierre amortiguado.

Great capacity waste cube with guides total extraction, 40 Kg and closure damaged.

Garbage grande capacité avec guides d'extraction totale, 40 kg et fermeture amortis.

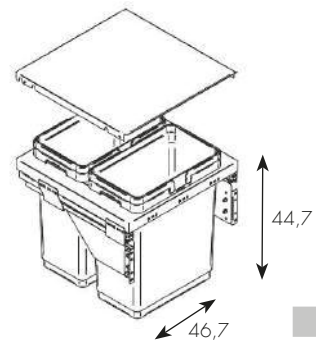

	Cod.
	867156
50	50

CUBO BASURA EXTRAÍBLE PLUS 60- 2 y 4 CUBOS

WASTE CUBE REMOVABLE PLUS 60- 2 & 4 CUBES | GARBAGE PAIL EXTRAIBLE PLUS 60 - 2 ET 4 CUBES

Cubo basura gran capacidad con guías de extracción total, 40 Kg y cierre amortiguado.

Great capacity waste cube with guides total extraction, 40 Kg and closure damaged.

Garbage grande capacité avec guides d'extraction totale, 40 kg et fermeture amortis.



2 CUBOS
2 CUBES
2 CUBES

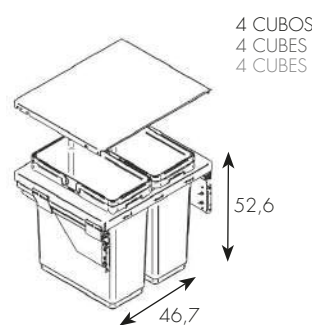

4 CUBOS
4 CUBES
4 CUBES

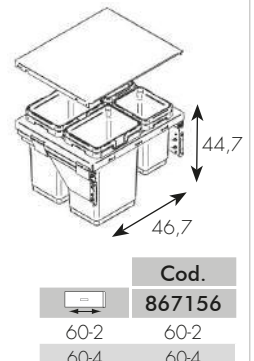

	Cod.
	867156
60-2	60-2
60-4	60-4

SIST. DE ILUMINACIÓN | LIGHTING SYSTEM | SYSTÈME D'ÉCLAIRAGE



FONDO LUMINOSO LED

BACKGROUND LIGHT LED | FOND LUMINEUX LED

Fondo luminoso ADA, con tecnología LED, apto para muebles de costado de 1,6 cm y 33 cm de profundidad.

Background ADA light, with LED technology, suitable for base furniture of 1,6 cm side and 33 cm depth.

Fond lumineux ADA, avec technologie LED, adapté pour meuble avec côté de 1,6 cm y 33 cm de profond.



		Cod.
	Wat	875001
60	9 W	60
70	10 W	70
80	12 W	80
90	13 W	90
100	14 W	100
120	19 W	120



ESTANTE MARCO ALUMINIO CON LUZ FLUORESCENTE

SHELF WITH FLUORESCENT LIGHT ALUMINIUM FRAME | ALUMINIUM STAND AVEC CADRE LUMIÈRE FLUORESCENTE

Estante decorativo de aluminio con bases de cristal y luz fluorescente. Interruptor incorporado.

Decorative shelf in aluminium with a glass base and fluorescent light. Built-in switch.

Étagère décorative en aluminium avec des bases de verre et de lumière fluorescente avec commutateur intégré.

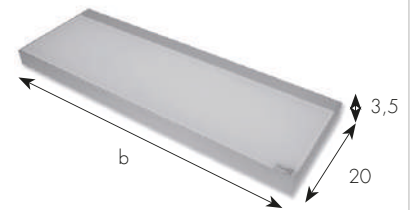

		Cod.
	Wat	875011
60	14 W	60
90	21 W	90
120	28 W	120



REGLETA SUPERFICIE LEDS GEO CORNER

STRIP GEO CORNER LED | BANDE LUMINEUSE LED GEO CORNER

Regleta de leds con luz natural sobre perfil de aluminio, para instalación en la parte posterior del mueble. Contiene interruptor.

LED strip with natural light on aluminium profile, for installation in the rear of the cabinet. It contains switch.

Bande de led avec lumière naturelle sur profil en aluminium pour l'installation à l'arrière de l'armoire.



Transformador TR-LED 24
6 conexiones



		Cod.
	Wat	875033
15 W	875033	
30 W	875034	

		Cod.
	Wat	875031
41,3	4,32 W	45
56,3	5,76 W	60
86,3	10,08 W	90
116,3	14,4 W	120
146,3	18,72 W	150
196,3	25,92 W	200
296,3	40,32 W	300



REGLETA ENCASTRE LED CONTINUA CON INTERRUPTOR

LED CONTINUOUS LIGHT WITH SWITCH | BANDE ENCASTRÉE LED À PLAT AVEC INTERRUPTEUR

Regleta de LED's con luz continua de sección plana, discreta y muy estética para encastre.

LED strip with continuous light of flat section, discreet and very aesthetic for fastening.

Bande LED à plat en continu, discret et très esthétique pour la section de verrouillage.



Transformador TR-LED 24
6 conexiones



		Cod.
	Wat	875036
15 W	875037	
30 W	875038	

		Cod.
	Wat	875036
41,3	4,32 W	45
56,3	5,76 W	60
86,3	10,08 W	90
116,3	14,4 W	120
146,3	18,72 W	150
196,3	25,92 W	200
296,3	40,32 W	300



LÁMPARA ALUMINO BGTO INTERIOR CAJÓN Y MUEBLE

LAMP ALUMINIUM BGTO DRAWER INNER | LAMPE ALUMINIUM BGTO INTÉRIEUR CABINET ET MEUBLE

Elegante barra de aluminio para iluminar el interior del mueble. Incorpora sensor de apertura del cajón, para el encendido.

Elegant aluminium bar to illuminate the inside of the drawer. Incorporates turn-on sensor for door opening.

Barre élégante aluminium. Pour éclairer l'intérieur du drawer, comprenant capteur.



Transformador TR-LED 24
6 conexiones

Wat	Cod.
15 W	875023
30 W	875024



	Wat	Cod.
		875022
b	Wat	Cod.
60	5,4 W	60
90	9 W	90
120	12,60 W	120

REGLETA GOLA MUEBLE ALTO LED DOBLE CON INTERRUPTOR

DOUBLE GOLA LED LIGHT HIGH CABINET WITH SWITCH | RÉGLETTE GOLA MEUBLE HAUT LED DOUBLE AVEC INTERRUPTEUR

Su diseño está concebido para encastrarlo en el frontal del mueble alto y permite que la puerta no necesite tirador.

Its design is designed to fit in the front of the high cabinet, and allows the door does not need a handle.

Son design est conçu pour coller à l'avant d l'unité murale, et permet à la porte n'a pas besoin de manipuler.

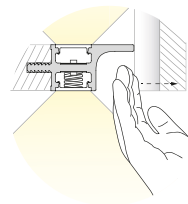
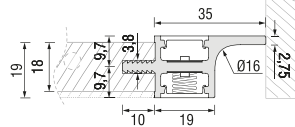
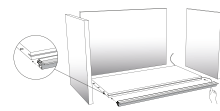

Wat	Cod.
30 W	875007
50 W	875008

	Wat	Cod.
		875006
b	Wat	Cod.
45	8,16 W	45
60	11,55 W	60
90	19,05 W	90
120	26,55 W	120

PERFIL LED BLANCO PARA CRISTAL 8MM

PROFILE LED BLANCO PARA CRISTAL DE 8 MM | PROFILE LED BLACK POUR LE VERRE 8 MM

Perfil de aluminio con tiras de leds blancos para colocar detrás de las baldas de cristal de 8 mm. No hace la función de soporte del cristal.

Profile of aluminacion with strip of white leds to place behind the shelves for 8 mm glass. It no do the function of the glass stand.

Profile d'aluminium avec del bandes blanches led pour placer derrière les étagères en verre de 8 mm.

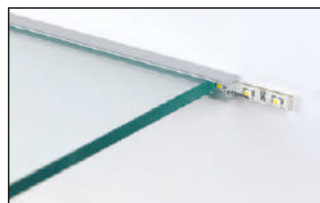

Cable que transforma salidas de 1 a 4
Cable that transforms outputs from 1 to 4
Câble qui transforme les sorties de 1 à 4

Transformador TR LED CR
2 conexiones



Wat	Cod.
25 W	875053
Cable 1-4*	875052

	Wat	Cod.
		875051
b	Wat	Cod.
45	1,3 W	45
60	1,5 W	60
90	2,4 W	90
120	3,3 W	120

FOCO CUADRADO SUPERFICIE

SURFACE FOCUS SQUARE | SPOTLIGHT CARRÉE SURFACE

Foco cuadrado de superficie, color aluminio y de luz natural.
Surface focus square, aluminium colour and natural light.
Spotlight ronde au carrée de surface, couleur aluminium et lumière naturelle.

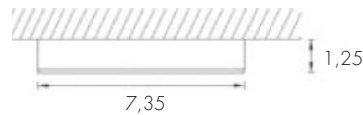

Transformador
TR-LED 350 MA



Wat	Cod.
15 W	875073
30 W	875074

Wat	Cod.
3,5 W	875072

FOCO CUADRADO ENCASTRE

SQUARE FOCUS BUILT IN | SPOTLIGHT CARRÉ ENCASTRÉ

Foco cuadrado de encastre, color aluminio y de luz natural.
Surface focus square built in, aluminium colour and natural light.
Spotlight ronde au carrée de encastré, couleur aluminium et lumière naturelle.

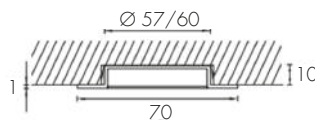
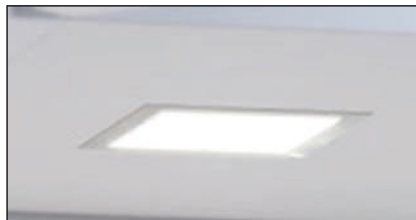

Transformador
TR-LED 350 MA



Wat	Cod.
15 W	875073
30 W	875074

Wat	Cod.
3,5 W	875072-E

FOCO REDONDO SUPERFICIE

SURFACE FOCUS ROUND | SPOTLIGHT RONDE SURFACE

Foco redondo de superficie, color aluminio y de luz natural.
Surface focus round, aluminium colour and natural light.
Spotlight ronde de surface, couleur aluminium et lumière naturelle.

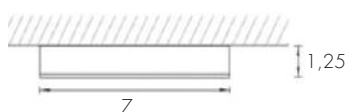

Transformador
TR-LED 350 MA



Wat	Cod.
15 W	875073
30 W	875074

Wat	Cod.
3,5 W	875071

FOCO REDONDO ENCASTRE

ROUND FOCUS BUILT IN | SPOTLIGHT RONDE ENCASTRÉ

Foco redondo de encastre, color aluminio y de luz natural.
Surface focus round built in, aluminium colour and natural light.
Spotlight ronde encastré, couleur aluminium et lumière naturelle.

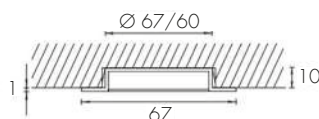

Transformador
TR-LED 350 MA



Wat	Cod.
15 W	875073
30 W	875074

Wat	Cod.
3,5 W	875071-E

FOCO SUPERFICIE LED ALUMINIO RECTANGULAR

SURFACE LED FOCUS ALUMINIUM SQUARE | SPOTLIGHT SURFACE LED ALUMINIUM RECTANGULAIRE

Foco con superficie de aluminio y luz natural. Instalando un foco con interruptor puede controlar el resto de los focos que no tengan interruptor y estén conectados en serie.

Focus with aluminium surface and natural light. Installing a focus with switch it is possible to control the rest of the focus having no switch if them are place in series.



Spotlight avec surface d'aluminium et lumière naturelle.

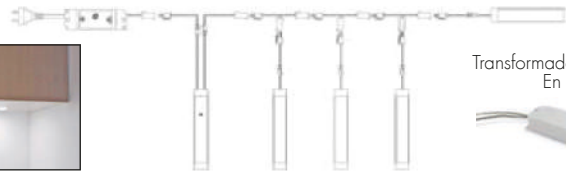
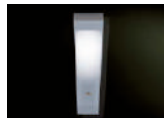

Transformador TR-LED 350
En Serie



Wat	Cod.
12 W	875083

	Wat	Cod.
Con interruptor	2 W	875081
Sin interruptor	2 W	875082

INTERRUPTOR CON SENSOR

SWITCH WITH SENSOR | COMMUTEUR AVEC CAPTEUR

Sensor de encendido táctil de enchastre. Diámetro de enchastre 11mm.

Ignition touch touch sensor. Diameter of recess 11mm.

Capteur tactile d'allumage. Diamètre de l'évidement 11mm.

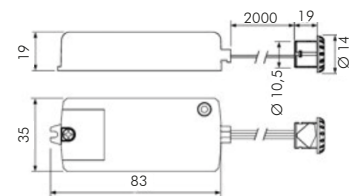

	Cod.
Simple	87509A
Doble	87509B

ENCHUFE ESCAMOTEABLE EXTRAÍBLE

POP-UP AND PULLOUT PLUG | PRISE RÉTRACTABLE EXTRAÏBLE

3 enchufes escamoteables, con tapa color aluminio para enrasar y que quede oculto sobre la encimera.

3 pop-up plugs, colour aluminium cover and make it hidden on the worktop.

3 prises rétractable, avec couverte en couleur aluminium pour enraser et est caché sur le comptoir.

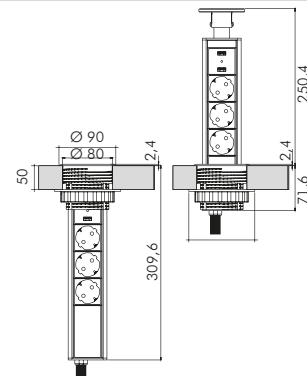

Cod.
875091

ENCHUFE EMPOTRABLE GIRATORIO

GYRATORY PLUG BUILT IN | PRISE ENCASTRÉE TOURNANT

Consta de 2 enchufes en acabado inox, que pueden quedar ocultos al girar la pletina con un suave movimiento.

Consists on 2 plugs in inox finish, wich may be hidden to the mounting plate with a gentle movement.

Consiste 2 prises terminaison acier peut être caché en tournement la plaque avec un doux mouvement.

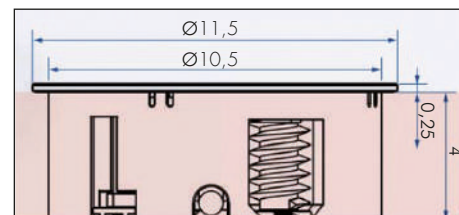

Cod.
875096



Dark grey upper cabinet with a light wood-grain open shelf containing jars of condiments.

Dark grey upper cabinet with a horizontal handle.

Black countertop featuring a curved faucet, a bottle of olive oil, and fresh produce including lemons, tomatoes, and onions.

Light wood-grain lower cabinet with horizontal handles.

Dark, shaggy rug on the floor.

CRISTALES | GLASS | VERRE



CRISTAL ESTANDARD / STANDARD GLASS / VERRE STANDARD

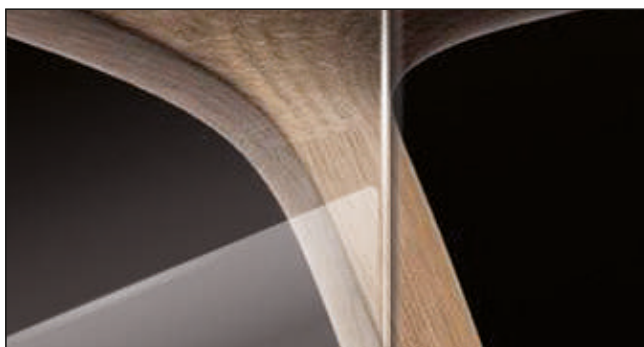

TRANSPARENTE

Cod.

880001

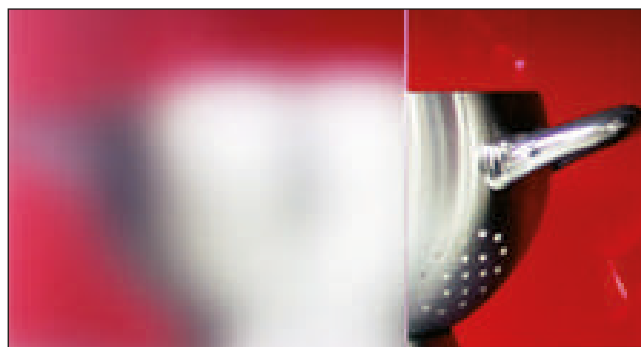

SATENLUX

Cod.

880007

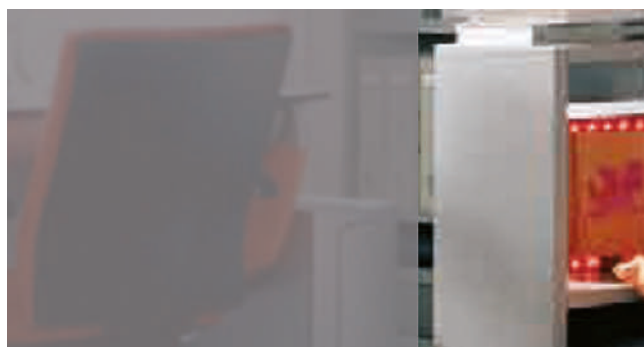

PARSOL GRIS

Cod.

880002



PARSOL BRONCE

Cod.

880003



THELA

Cod.

880017

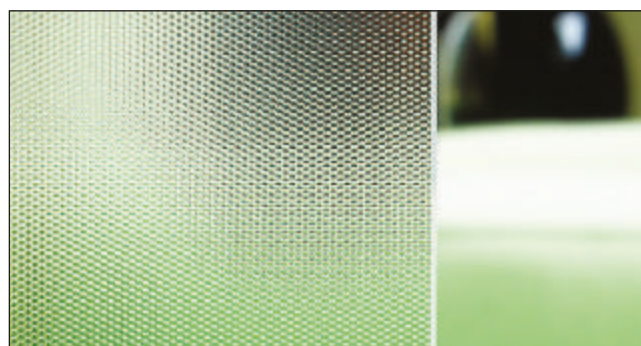

SCREEN

Cod.

880016

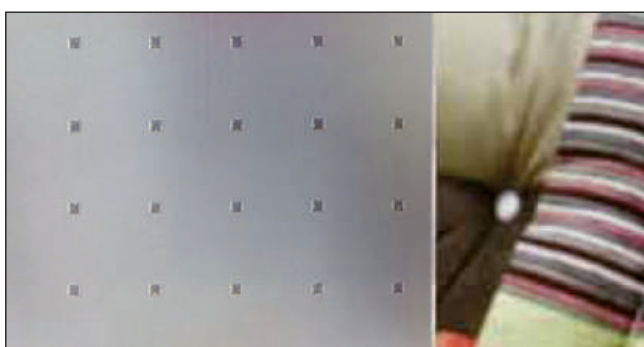

MASTER PICKS BLANCO

Cod.

880006

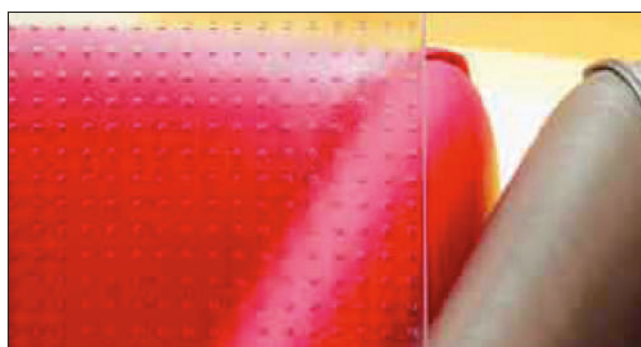

MASTER CARRÉ

Cod.

880005

Consultar cristal biselado. | Consult beveled glass. | Consultez verre biseauté.



CRISTAL LAC / LAC GLASS / CRISTAL DE LAC



BLANCO ÓPTICO

Cod.
880012 4BO



BLANCO

Cod.
880012 4BL



BEIG

Cod.
880012 4BG



ROJO FERRARI

Cod.
880012 4RF

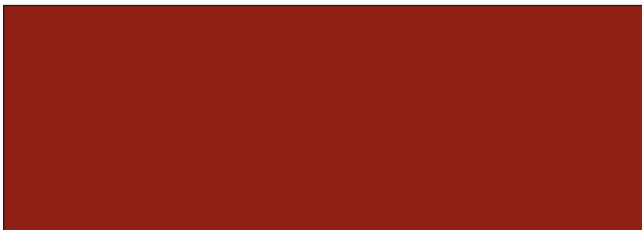

BURDEOS

Cod.
880012 4RB

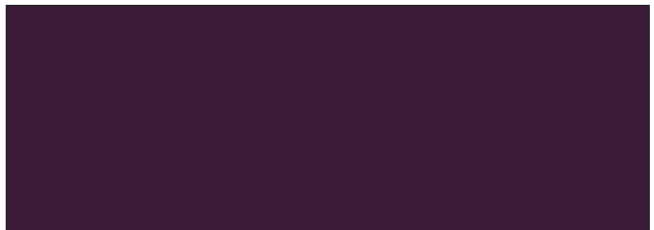

MORADO

Cod.
880012 4MO



GRIS

Cod.
880012 4GR



NEGRO

Cod.
880012 4NG

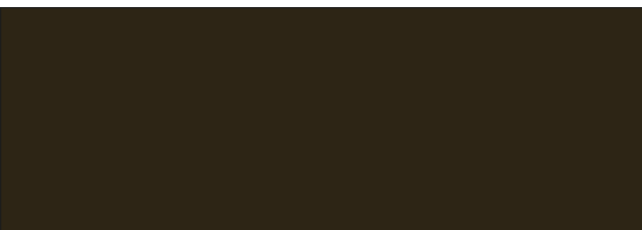

MARRÓN

Cod.
880012 4MR

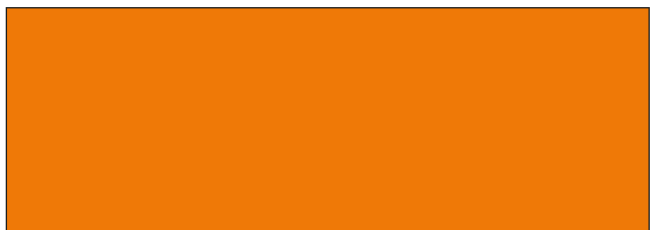

NARANJA

Cod.
880012 4NJ

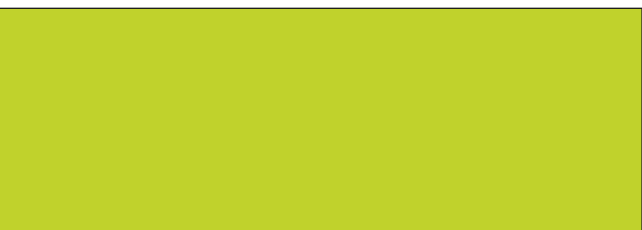

VERDE

Cod.
880012 4VD



AZUL

Cod.
880012 4AZ

ESTANTE CRISTAL

GLASS SHELVES | ÉTAGÈRE EN VERRE

Estante cristal transparente de 6 mm para mueble alto y bajo.

Shelf transparent glass 6mm furniture tall and bas.

Étagère en verre transparent de 6 mm pour meuble haut et bas.



Cod. M. Alto 881001			Cod. M. Bajo 881001		
b	c		b	c	
26,7	29,5	A30	26,7	51	B30
31,7	29,5	A35	31,7	51	B35
36,7	29,5	A40	36,7	51	B40
41,7	29,5	A45	41,7	51	B45
46,7	29,5	A50	46,7	51	B50
56,7	29,5	A60	56,7	51	B60
66,7	29,5	A70	66,7	51	B70
76,7	29,5	A80	76,7	51	B80
86,7	29,5	A90	86,7	51	B90
96,7	29,5	A100	96,7	51	B100

SOPORTE ESTANTE CRISTAL EXTRA

EXTRA GLASS SHELF SUPPORT | SUPPORT ÉTAGÈRE EN VERRE EXTRA

Soporte de estante de vidrio con cierre.

Glass shelf support with closure.

Support à tablette en verre avec fermeture.

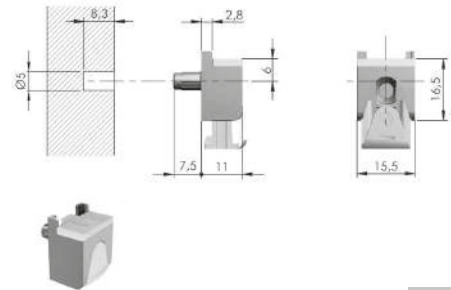
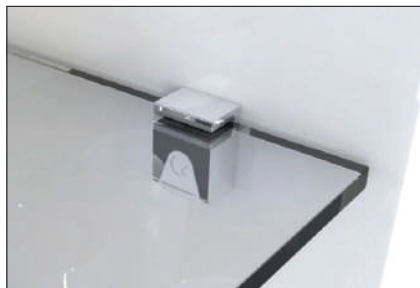

Cod. 843012

SOPORTE ESTANTE CRISTAL

SUPPORT GLASS SHELVES | SUPPORT ÉTAGÈRE EN VERRE

Soporte para estante de cristal, de zamak, con gota de silicona.

Support for glass shelf, zinc die-casting, with drop of silicone.

Support pour étagère en verre de zamak avec gouttelettes de silicone.

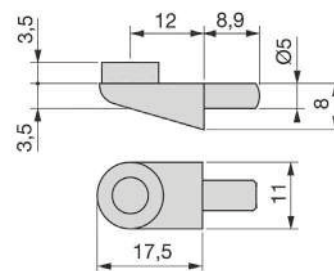

Cod. 843011

APLACADO CRISTAL

GLASS WALL CLADDING | REVÊTEMENT MURAL VERRE

Aplacado de cristal para pared, en diferentes colores. Con opción de cajeros y cortes de enchufe. Presupuesto sobre plano.

Glass cladding of wall, in different colors. With optional plug cutouts and cuts. Budget plan.

Paroi de placage de verre, de couleurs différentes. Avec les compressions et les compressions prise en option. Plan budgétaire.



BC3
COCINAS

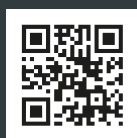

www.bc3.es

